

The Audio Critic®

Issue No. 21

Display until arrival of
Issue No. 22.



Retail price: U.S. \$7.50, Can. \$8.50

**Unconventional deployment of conventional drivers,
with superior results. (See the loudspeaker reviews.)**

In this issue:

We present the definitive article for audiophiles on the subject of digital jitter, written by one of the world's top experts in response to the appalling misinformation spread by the high-end audio press.

Your Editor reviews an unusually interesting and varied assortment of loudspeaker systems.

We take a first look at the Sony MiniDisc system.

David Rich dissects analog and digital electronics by Harman Kardon, Krell, Parasound, Sentec, et al.

Plus many other test reports, all our regular columns, letters to the Editor, and CD reviews by David Ranada.



Contents

10 Clock Jitter, D/A Converters, and Sample-Rate Conversion

By Robert W. Adams, Analog Devices, Inc., Wilmington, MA

25 Loudspeaker Systems Using Forward-Firing Cones and Domes: How Good Can They Get?

By Peter Aczel, Editor and Publisher

- 25 B&W Matrix 803 Series 2
 - 26 NHT Model 3.3
 - 28 Sequerra Model NFM-PRO
 - 29 Velodyne DF-661 (quick preview)
 - 30 Magneplanar MG-1.5/QR (dipole)
 - 31 Bag End ELF Systems S10E-C and S18E-C (subwoofers)
 - 33 MSB Acoustic Screens (acoustical accessory)
-

34 Analog Electronics: More Power Amplifiers, Preamp/Control Units, and Mild Surprises

By David A. Rich, Ph.D., Contributing Technical Editor

- 34 *Stereo Power Amplifier*: Harman Kardon PA2400
 - 36 *Full-Function Preamplifier*: Harman Kardon AP2500
 - 38 *Line-Level Remote Preamplifier*: Krell KRC-2
 - 41 *Stereo Power Amplifier*: Parasound HCA-2200II
 - 44 *Line-Level Preamplifier*: Rotel RHA-10 (quick preview by the Editor)
 - 44 *Stereo Power Amplifier*: Rotel RHB-10 (quick preview by the Editor)
-

45 Digital Electronics: More CD Players, D/A Processors, Transports, and a First Look at the Sony *MiniDisc* System

By Peter Aczel, Editor and Publisher

& David A. Rich, Ph.D., Contributing Technical Editor

- 45 *Outboard D/A Converter*: EAD DSP-90000 Pro (Reviewed by Peter Aczel)
 - 46 *Compact Disc Player*: Harman Kardon HD7725 (Reviewed by David Rich)
 - 48 *Outboard D/A Converter*: Krell Studio (Reviewed by David Rich)
 - 50 *DAC/Line Amplifier*: Monarchy Audio Model 33 (Reviewed by Peter Aczel)
 - 53 *CD/Videodisc Transport*: Monarchy Audio DT-40A (Reviewed by Peter Aczel)
 - 53 *Outboard D/A Converter*: Sentec DiAna (Reviewed by David Rich)
 - 55 *Compact Disc Player*: Sony CDP-X707ES (Reviewed by Peter Aczel)
 - 56 *2nd-Generation MiniDisc Recorder*: Sony MDS-501 (Reviewed by Peter Aczel)
-

57 High-Definition Thinking in Small, Furry Mammals

or The Weasel's Guide to Maximum Satisfaction

By Tom Nousaine

60 Hip Boots Wading through the Mire of Misinformation in the Audio Press

Six commentaries by the Editor

62 Recorded Music A Miscellany of CDs and Musical Videodiscs

By David Ranada (with a few additional capsule reviews by the Editor)

3 Box 978: Letters to the Editor



Issue No. 21

Spring 1994

Editor and Publisher	Peter Aczel
Contributing Technical Editor	David Rich
Contributing Editor at Large	David Ranada
Technical Consultant	Steven Norsworthy
Columnist	Tom Nousaine
Cartoonist and Illustrator	Tom Aczel
Business Manager	Bodil Aczel

The Audio Critic® (ISSN 0146-4701) is published quarterly for \$24 per year by Critic Publications, Inc., 1380 Masi Road, Quakertown, PA 18951-5221. Second-class postage paid at Quakertown, PA. *Postmaster:* Send address changes to The Audio Critic, P.O. Box 978, Quakertown, PA 18951-0978.

The Audio Critic is an advisory service and technical review for consumers of sophisticated audio equipment. Any conclusion, rating, recommendation, criticism, or caveat published by *The Audio Critic* represents the personal findings and judgments of the Editor and the Staff, based only on the equipment available to their scrutiny and on their knowledge of the subject, and is therefore not offered to the reader as an infallible truth nor as an irreversible opinion applying to all extant and forthcoming samples of a particular product. Address all editorial correspondence to The Editor, The Audio Critic, P.O. Box 978, Quakertown, PA 18951-0978.

Contents of this issue copyright © 1994 by Critic Publications, Inc. All rights reserved under international and Pan-American copyright conventions. Reproduction in whole or in part is prohibited without the prior written permission of the Publisher. Paraphrasing of product reviews for advertising or commercial purposes is also prohibited without prior written permission. *The Audio Critic* will use all available means to prevent or prosecute any such unauthorized use of its material or its name.

Subscription Information and Rates

First of all, you don't absolutely need one of our printed subscription blanks. If you wish, simply write your name and address as legibly as possible on any piece of paper. Preferably print or type. Enclose with payment. That's all. Or, if you prefer, use VISA or MasterCard, either by mail or by telephone.

Secondly, we have only two subscription rates. If you live in the U.S., Canada, or Mexico, you pay \$24 for four consecutive issues (scheduled to be mailed at approximately quarterly intervals). If you live in any other country, you pay \$38 for a four-issue subscription by airmail. All payments from abroad, including Canada, must be in U.S. funds, collectable in the U.S. without a service charge.

You may start your subscription with any issue, although we feel that new subscribers should have a few back issues to gain a better understanding of what *The Audio Critic* is all about. We still have Issues No. 11, 13, 14, and 16 through 20 in stock. Issues earlier than No. 11 are now out of print, as are No. 12 and No. 15. Please specify which issues you want (at \$24 per four).

One more thing. We don't sell single issues by mail. You'll find those at somewhat higher cost at selected newsdealers, bookstores, and audio stores.

Address all subscriptions to The Audio Critic, P.O. Box 978, Quakertown, PA 18951-0978. VISA/MasterCard: (215) 538-9555.

From the Editor/Publisher:

Issue No. 20 was optimistically dated Late Summer 1993 but was mailed in the second week of the fall. Unforeseen delays resulted in one omitted quarter; hence the more realistic Spring 1994 dating of this issue. The staff expansion I so fondly previewed is still in the incipient stage. With all the reviews in this issue, it was suggested to me that I split it down the middle to make it into two issues (maybe I should have), or label it a double issue in fulfillment of two quarters of a subscription (I would never do that). Yes, there will be a Summer 1994 issue, possibly even sooner than you think.

Box 978

Letters to the Editor



In the last issue your Ed. griped in this space about uninteresting letters seeking advice on purely private purchasing plans (alliteration unintended). Now I want to gripe about reasonably interesting but unpublishable letters that ramble on for seven or eight illegibly handwritten pages, propounding the correspondent's opinions on eleven different audio subjects. What is the purpose of such a letter? What am I supposed to do with it? Get a life, guys—or get a word processor. Letters printed here may or may not be excerpted at the discretion of the Editor. Ellipsis (...) indicates omission. Address all editorial correspondence to the Editor, The Audio Critic, P.O. Box 978, Quakertown, PA 18951.

The Audio Critic:

When making the suggestion that Berlioz was worthy of joining "the 3 B's" [Issue No. 17, p. 57], you likely never knew that Liszt's disciple Peter Cornelius coined the formula with Berlioz as the third! Bülow signaled his revolt from Wagner (who had earlier stolen his wife Cosima, née Liszt) by purloining the phrase to glorify Brahms.

Actually "the 3 B's" may be held nonsense by Magyars, or other non-Teutons (such as I). So is your warning that Berlioz's worst is probably worse than Bach's, Beethoven's, or Brahms's worst. Since Berlioz is the lone great composer who was never granted full "canonization" (which can account for your electing him so shyly to "3 B" status, and the rare event of Inbal's semicycle recordings: he'll never be subjected to the fashion), he still suffers from such preposterous slights, even from renowned musicians (e.g., Celibidache and Nigel Kennedy), which only an exceedingly bold critic would make against the others.

Can you recall Tovey's remarks—of which Haggin was so fond—that "neither Shakespeare nor Schubert will ever be understood by any critic or artist who re-

gards their weaknesses and inequalities as proof that they are artists of less than the highest rank," and that "the highest qualities attained in *important* [my emphasis] parts of a great work are as indestructible by weaknesses elsewhere as if the weaknesses were the accidents of physical ruin." Tovey wrote that to exalt Schubert against the shallow regard then rampant but now all but extinct...

I don't overlook the fact that the music of Berlioz pleases you greatly. (A visitor to Wagner reported that he first said that Romeo and Juliet's Love Scene, just as wisely called the Adagio of Berlioz's 3rd Symphony, was "the most beautiful music ever composed.") A superior critic (and Nobel-winning novelist) of France, Romain Rolland (also friend and correspondent of Freud!) enrolled Bach, Handel, Mozart, Beethoven, Schubert, and Wagner as the finest of all composers and claimed that after them he knew no other who was superior, even equal, to Hector Berlioz. Berlioz seemed incapable of the vulgarity (or kitsch or bathos) which afflicts German composers, and Brahms especially (ever seen Cary Grant conduct the Academic Festival Overture in *People Will Talk?*), and so became approved

and emulated in all Western music...

...While comparing one and another's worst and best, what is gained from tallying pages, measuring the stacks of bad and good? Yet you felt compelled to indulge this pointless fancy at Berlioz's expense....

Sincerely,
Owen M. Feldman
Elkins Park, PA

Ha! Fooled you all—didn't I?—by beginning this column with a music-oriented letter rather than audio talk. My main reason for doing so was actually to contradict my preamble above with, shall we say, the exception that proves the rule. This letter came written in a small, compressed hand on what appears to be a legal-size yellow pad, then very badly Xeroxed and the copy sent instead of the original. I chewed my way through 3/4 legal-size pages of smeared, streaked, gray mess and decided to publish about a fourth of it because I found it interesting and entertaining. I'm not taking back a single word of my preambulatory comments, but I guess I am a sucker for knowledgeable music talk. It's certainly a nice change from tweako audio talk. I'll

even apologize for my churlishness anent Berlioz's small lapses; on second thought they're probably no worse than Bach's or Beethoven's. Besides, a man who is even slightly underwhelmed by Brahms can't be all bad and should be humored.

-Ed.

The Audio Critic:

..."Accountability in audio journalism" and your no-nonsense, rational approach to product reviews are a refreshing change and a source of continuing entertainment for me. David Rich is a superb find.

Regarding the MTM [mid/tweet/mid] driver geometry, you are correct in that I was not the first to use it (Issue No. 20, page 42). To my knowledge the earliest commercially successful use was by Koss in a small 2-way system with 4" mid/bass drivers. The choice of this geometry by Koss, however, appeared to be largely cosmetic. Meridian also made such a system about the time my paper appeared ["A Geometric Approach to Eliminating Lobing Error in Multiway Loudspeakers," 74th Convention of the AES, New York, 8-12 October 1983, Preprint 2000], but again no mention of its superior polar response was made by them.

With Linkwitz's 1976 paper the problem of polar-axis frequency-dependent wander or lobing error became widely appreciated. Linkwitz's solution to the problem was to use inphase crossover networks. I was the first to demonstrate in the open literature that the MTM geometry automatically eliminates lobing error and to show the relationship between polar response and crossover order for this geometry. I also designed several commercially successful loudspeaker systems and system kits using this geometry. Two of these systems were featured in *Speaker Builder* magazine. The "Auditor Point Source Aria Five," a Focal/JML product which sold exclusively in Europe, won the best loudspeaker of the year award for 1991 from *Hifi Vidéo* (Paris, March 1991). The MTM geometry is now widely used and several manufacturers have attributed the concept to me in their promotional literature. I believe it is for these reasons that the MTM geometry has become associated with my name.

Yours truly,

Joseph D'Appolito, Ph.D.
Andover, MA

Thank you for the compliments. Isn't

it remarkable that technologists with the highest credentials, such as you, always like us and that the scattered little enclaves of hostility out there are invariably peopled by the technically untutored?

As for the MTM geometry, I myself was the grunt of a design team (Bruce Zayde, now with Hewlett-Packard, was the whiz) that developed such a speaker in 1984-85. It was called the Fourier 44 (because of the two 4 1/2" mid/bass drivers) and shown at the 1985 Summer CES. A few studio types and broadcasters are still using it as a small monitor. We didn't attach the D'Appolito appellation to it, but conceptually the crossover was along the Linkwitz/D'Appolito guidelines. The speaker is currently extinct.

Audio designers have been known to claim credit for work done by others, but you are the first in my experience to disclaim, or heavily circumscribe, credit for something the world has already fully credited to you. That's what I call a class act!

—Ed.

The Audio Critic:

Sorry, Charlie! This \$24 is going to *Stereophile* I am sitting in the smallest room of my house with your so-called magazine in front of me. It will soon be behind me. I'm sorry I ever wasted a cent on your rag.

[—Unsigned]

*The above anonymous and untraceable message was scribbled on a blank copy of our pink form soliciting renewal of an expired subscription and returned to us in our business reply envelope at our expense. I am publishing it as a clue to the sociocultural/intellectual profile of those who opt for *Stereophile* in preference to our publication. Such class! Such wit! But such an awkward seat for letter writing! (Needless to say, I washed my hands after handling the form.)*

—Ed.

The Audio Critic:

In Issue No. 20, Drew Daniels' letter cited a transmission line's electrical length as analogous to the phase shift in a length of speaker cable. This is not true. A speaker cable is in effect a lowpass filter—your own curves in Issue No. 16 clearly show this. Depending on the LCR of the cable, the driving impedance (amplifier), and the load impedance (speaker), the cutoff frequency could take place

within or, hopefully, above the audio band.

The phase shift within the audio band is determined by all of the above, but generally will be capacitive (negative degrees) at low frequencies, pass through resistive (zero degrees), then become inductive (positive degrees) at higher frequencies. In any case, even modest lengths of any of the cables sold today will exhibit many degrees of phase shift at the speaker terminals as a function of frequency. The only way to avoid power loss, high-frequency rolloff, reduced damping factor (drastic in some cases), and phase shift (although I don't know that this is important) is to use no speaker cable. Your own suggestion to use mono amps at the speakers' backs with short jumpers is a most valid one.

Another subject: May I respectfully decline to accept your request to contribute for the advancement of Bob Harley's technical education? I find his "jittery" stepping through technical issues very amusing and entertaining. With more education he could become dangerous—another Martin Colloms!

Don't give in to those who would like you to compromise with the witch doctors. Someone has to bring all the hype to the forefront and it appears you are the only one.

Sincerely,

Jefferson P. Lamb
Incline Village, NV

It seems to me that Drew Daniels and you are talking about two different things. He talks about phase shift as related to propagation speed in an unterminated wire, which is an abstraction; you talk about a real-world hookup with an amplifier output impedance plus wire characteristics plus a complex load impedance presented by the speaker. Yes, of course, with your givens your conclusions apply, but then the issue becomes the sound of the amplifier/wire/speaker, not just the sound of the wire due to its length, which is the "moronic" subject that incenses Drew.

Anent the SHEESH (Send Harley to E.E. School in a Hurry) Fund, see the "Hip Boots" column in this issue. Now, what you don't seem to realize is that Martin Colloms is actually two persons existing in parallel universes. There is the techie Martin Colloms, made of matter. There is the tweako cultist Martin Colloms, made of antimatter. The two

THE AUDIO CRITIC

cannot possibly get together because that would cause a cataclysmic explosion annihilating Hi-Fi News & Record Review and maybe even Stereophile. That's why he is dangerous.

—Ed

The Audio Critic:

"Dear" Peter,

Your continued hysterical, personal attacks on me are entertaining as usual. As is Ken Pohlmann's letter, which explains his affinity for you: he too is a petulant, name-calling infant. Why don't you do this: survey the top LP and CD masterers in the field—the folks who have access to the master tapes and the CD transfers. Ask them, as I have, whether the CDs—especially those made from an analogue tape—sound like the original. And ask them whether they prefer the sound of a CD or a properly manufactured and played-back LP.

Ask Doug Sax, Bernie Grundman, Greg Calbi, Bob Ludwig, Ted Jensen, Stephen Marcussen, Steve Hoffman, Howie Weinberg, Bill Inglot, etc. Ask Grammy-award-winning engineer Roy Halee (Paul Simon, etc.) about digital recording, or any of the dozens of veteran recording engineers I've surveyed on the subject. Some like digital, many don't. I'd be happy to provide you with a list. [I thought you just did.—Ed.]

Here's a good one: call veteran jazz producer Michael Cuscuna of Mosaic Records and ask him what happened when, without alerting his customers, he started releasing LPs generated from "perfect" digitally remastered analog source material. He'll tell you this: virtually all of them heard the deleterious effects of digitization and called to complain.

Or better yet, reprint the following so all five of your new readers [currently a minimum of five new readers a day, Michael, but usually more—Ed.] can read it:

Help Stop the Digital Epidemic!

It has become a mindlessly parroted truism in the world of commercial audio that digital recording is the state of the art and the wave of the future. At the same time, there isn't a single audiophile-oriented equipment reviewer, record producer or music critic who finds the treble range of current digital recordings musically natural and enjoyable. The present technology of 50,000 samples per second with 16-bit encoding/decoding is sim-

ply inadequate and mustn't be allowed to become the world standard. If you agree with us, start writing letters to the record companies and commercial magazines before it's too late.

Let's see, who wrote that? Could it be...SATAN? NO. It's from *The Audio Critic*, Spring through Fall 1980, and judging by the tone I'd say you wrote it, you opportunistic slug.

Cheers,
Michael Fremer
Senior Editor
The Absolute Sound
Sea Cliff, NY

If listing Senator Robert Dole as one of the anti-Clinton Republicans constitutes a hysterical, personal attack on him, then listing you as one of the antidigital audio journalist—which was all I did (Issue No. 20, p. 13)—constitutes a hysterical, personal attack on you. It seems to me, however, that once again (see Issue No. 14, pp. 9 and 51) you are the pot calling the kettle black. Isn't calling Ken Pohlmann "a petulant, name-calling infant" an act of name-calling—both hysterical and personal? Weren't your remarks about him in the Winter 1993 issue of The Absolute Sound, threatening to vomit on him at a CES dinner, infantile, personal, and name-calling? Let me do some fact-calling: Ken Pohlmann has a graduate degree in E.E.; you do not. Ken Pohlmann is a professor at a major university; you are not. Ken Pohlmann is the author of a basic textbook on digital audio; you are not. Ken Pohlmann is a Vice President of the Audio Engineering Society; you are not. Shall I go on? Shall I insult you with a spelled-out conclusion? I think that will be unnecessary.

As for your list of names—a couple of them well-known, others less so—you say "some like digital, many don't," so what's your point? Which of them don't? I can trump each digitophobic name you bring up with three world-class names to the contrary; it's a silly game. The point is not who likes digital; the point is the inherent accuracy, or lack thereof, of the linear PCM technology and of A/D and D/A conversion. That's an important subject that needs to be addressed repeatedly and is the main reason I am answering your trivial crank letter at such length.

No one claims, I least of all, that everything that has ever appeared on CD sounds great. There are plenty of opportunities to mess up between the first A/D

and last D/A stage in the recording and playback chain; it used to happen often but now it's much rarer. The basic question, and the only intelligent one, is this: between a state-of-the-art DDD compact disc and a state-of-the-art all-analog vinyl disc, each free from all the possible technical goofs, which reproduces with greater accuracy and fewer spuriae the signal from the microphones? If anybody thinks the answer is uncertain (as it is not), let me add one other reasonable constraint: 50 playbacks. Have I made my point? If you eliminate the vinyl, the picture changes; today's best analog and digital master tapes can sound quite comparable overall, but the signal-processing possibilities are much more limited with analog, and as a storage format digital is considerably more stable.

That brings me to my 1980 comments on "the digital epidemic." There were no CDs in those days; the only readily available examples of the new digital audio technology were vinyl LPs cut from digital master tapes. They sounded pretty bad. I mistakenly attributed the bad sound to the digital process. I was dead wrong, as later CD releases of those same digital master tapes clearly showed. It was the transfer to the LP medium that was bad because the engineers who did the transfers initially refused to deal with the differences in high-frequency energy and dynamic range between analog and digital master tapes. I had no idea how the digital tapes sounded in the control room at the recording sessions. I jumped to the wrong conclusion, and my advisors at the time were no smarter. Have you ever jumped to the wrong conclusion, Michael?

As for "opportunistic slug"—boy, that's a muddleheaded, inept insult. What opportunities does a snail without a shell exploit unfairly? What undeserved advantages did I gain by repudiating and correcting my early perceptions of digital audio? You, sir, are a very lightweight polemist.

—Ed.

* * *

Epilogue: At the Winter CES in Las Vegas early in January, Michael Fremer deliberately staged a loud, public, fishwifely confrontation with me for the benefit of visitors to the Velodyne exhibit. It was uncalled-for and embarrassing; I later had to clear the air with David Hall, Velodyne's boss, who is a soft-spoken gentleman unaccustomed to the

streets-of-New-York type of vulgarity. I tried to calm Michael by telling him that I did not consider him to be an evil person but just someone with absurd ideas, but he kept loudly accusing me of "ad hominem attacks" (his editor, Harry Pearson, also loves that phrase) and looking around for group approval. I then made the mistake of tossing off a small pedantic joke. I asked, "Who was the homo in hominem?" Then I added, "You know, hominem is the accusative of homo, required by the preposition ad." Michael did not get the Latinist jest. His confused reaction indicated that all he had heard was the word homo, and I'm not even sure he knew it means man. That will teach me to make gratuitous scholarly noises where the cultural tone is New York candy store. Indeed, that will teach me to have any kind of commerce with the Fremeroid element in the audio world.

The Audio Critic:

It's been roughly two years or so since my departure from "tweako/voodoo salon" land, and I owe thanks to you and your staff for the insight and knowledge you share through *The Audio Critic*. It's amazing what science and a little common sense can do for the soul. As the song states, "I was once blind but now I see!" My only regret is that some of the information is a little technical for those "laymen" who are not a part of the engineering kingdom. I would be grateful if you could dilute some of the techno-lingo from time to time.

Throughout the years, I've noticed that many audio magazines rarely even mention the name McIntosh. The company has been around since 1949 and has a solid reputation for reliability and quality, just like Krell, Bryston, etc., yet the tweaks hardly touch it. Why? The design (external appearance) may be a bit out of date for some, but the internal components hardly seem archaic. According to the principles presented in your publication, if the McIntosh amps operate within their given parameters, then they should sound no different than a Krell or Boulder. Thus, these amps should be highly regarded and recommended, unless there's something I've missed. How about *The Audio Critic*, in a future issue, taking the opportunity to test a McIntosh amp. I would love to see how it compares to some of the other big boys on the block...

Please keep up the excellent work.

Your magazine lights the path for many in a confused and disturbed audio world.

Sincerely,
Mark S. Williamson
Washington, D.C.

I blush because your words of praise make me appear to be something close to a spiritual leader, a responsibility I refuse to shoulder. (Lenny Bruce once said that anyone who calls himself a religious leader and owns more than one suit is a hustler. I own two suits.)

McIntosh is indeed an interesting company. You are quite right; they make, and always made, beautifully engineered equipment. During their long years under the leadership of the late Gordon Gow, they kept their dialogue with the high-end audio press to a minimum, probably because they felt that with their thoroughly established reputation and highly supportive dealer network they had nothing to lose as a result of an irresponsible tweako hatchet job. Hey, they were probably right.

About two years ago the picture changed somewhat. The firm is now owned by the Japanese; the new management is not from the high-end audio world and is gung ho on marketing, PR, the whole big-business canon. They have a new car-audio line, among other things. So far, from where I'm sitting, I can discern no compromise whatsoever with traditional McIntosh engineering or product integrity, and the party line is that there will be none. Amen. They are definitely cozier with the audio press, however; you will undoubtedly see more reviews, and I think that will include reviews in this publication. Based on what I already know, I expect their power amplifiers, especially, to do very well in engineering shootouts with some of the sacred cows of the High End.

—Ed.

The Audio Critic:

I just read my first issue of *The Audio Critic* (No. 20). I can only say that I have been looking for this type of coverage of the audio industry for several years and have found it only in this one publication. I first became involved in audio as a teenager in 1966, working in what was then a "high-end" audio store in San Francisco. I have remained interested and involved ever since.

I have been an avid reader of all the

popular audio publications over the years except for *Stereophile* and *The Absolute Sound* (by the time I discovered these last two, they had become too involved in beliefs in the superiority of older tube and analog equipment for my taste). I have had a subscription to *Audio* since the late '60s. In recent years I have become highly disillusioned with the direction of most publications and audio salons. So-called "high-end" audio is becoming more and more an exercise in frustration rather than the source of pleasure it should be. We are not told what sounds good but rather what is wrong with the sound of just about everything out there except maybe one of those \$150,000 all-out high-end systems. There is far too much emphasis on the cost of components and how cost is related to "sound quality," even though most high-enders will deny it.

At one time I was going to be an audio engineer. I chose instead to become a psychologist but have never left my scientific orientation. As a result, I have become what might be termed a psychological critic. I have remained true to only empirically based studies of behavior and have taken many courses in research design and statistics. There are some interesting parallels between psychology and high-end audio, the most obvious being the lack of empirical support for the assertions that are so commonly made. Psychology always has been and continues to be filled with interesting but often worthless theories that become the basis for interesting but often worthless therapies. As in high-end audio, the public can spend hundreds of thousands of dollars on technologies (therapies) that are of dubious value.

I had become so frustrated with the audio scene over the last year or so that I was hardly even reading anything anymore. In trying to purchase some audio products during this same time, I was convinced to buy some products by an audio salesman, which turned out to be a big mistake. Luckily the store that had sold them to me was happy to give me my money back when I returned them unhappy. However, this was for accessories like cables, not big-money items like speakers, amplifiers, or preamps. I even got into a big argument with a salesman about the purchase of a Toslink cable for copying CDs onto DAT. I was told that several other products were far superior and "what I really wanted was..." What I really wanted was a Toslink cable! Dur-

ing the argument, I heard things like "...but according to Robert Harley..." I am not an engineer but I was skeptical of Mr. Harley's qualifications based on many statements he had made in *Stereophile*. The salesman exhibited his own ignorance when it became clear that he did not know what a ground loop was. I became so angry at the salesman's persistence and ignorance that I left the store and returned later to buy my Toslink cable from another salesman (this was the only store in town that carried the cable).

Some of your readers have written to suggest that you cease your "tweak bashing" and "ignoramus hunting." I have written to both *The Absolute Sound* and *Stereophile* over the years to criticize their views on various topics, but mostly to point out their lack of understanding of scientific methods (mostly *Stereophile*). *The Absolute Sound* published two of my letters but "disqualified" my point of view in print by pointing out how inferior my equipment was and claiming that I would not be able to hear the things they were talking about with such equipment. *Stereophile* has never published or acknowledged any of my letters. Like *The Audio Critic*, I have tried to write letters to *Stereophile* that were "unanswerable," after my experience with *The Absolute Sound*.

The Audio Critic appears to be the only publication I am aware of that takes a truly serious approach toward the evaluation of so-called high-end components. Given the prices some of these components currently have, such a serious approach is really needed. Just as importantly, given the pervasive misconceptions about high-end audio components that exist today, the "tweak bashing" and "ignoramus hunting" in *The Audio Critic* probably does not go far enough. I'm not suggesting that more attacks are needed, but that more clarification is needed and somehow outside of this one publication. Audio should not be the "sport" that Anthony Cordesman so often refers to it as (sport in that context seems to denote the constant trading of usually expensive equipment in the never-ending quest for perfection, and the fun of debating the theoretical issues) but rather a means to enjoy music outside the concert hall with as much realism as possible at an affordable price and without having to have a degree in electrical engineering. As an aside, I can no longer wade through what I call the "high-end babble" that so per-

vades Mr. Cordesman's reviews in *Audio*.
Sincerely,
Chuck Butler
Kalamazoo, MI

Your comparison of psychology and high-end audio is right on the money. You haven't told us, however, how a layman in search of effective therapy can distinguish, and navigate, between the sophisticated empiricists and doctrinaire theoreticians in your profession—it's a tough question, isn't it? In audio, the answer to the analogous question is implicit in your complimentary remarks: every man, woman, and child who owns more than three CDs should have a subscription to The Audio Critic, right?

—Ed.

The Audio Critic:

Tom Nousaine, for whatever reason, seems incapable of accurate reportage about me or my views. Having given to the readers of *The Audio Critic* a distorted picture of our not unpleasant encounter at the *Stereophile* High-End Show last year, he then compounds his errors by perverting some perfectly clear statements from Professors Greiner and Lipshitz on the audibility of absolute polarity. I beg to set the record straight on these latter facts.

"[Lipshitz's] results were significant only when trials using test tones were included in the analysis," Nousaine says. On the contrary! Listen up:

[Here follows a series of referenced quotations from the writings of Lipshitz, Greiner, Richard Heyser, et al., with pithy anti-Nousaine comments by the letter writer. The trouble is that the quotations are heavy-handedly selected, excerpted, and edited with massive ellipses, omitting the qualifying words, phrases and sentences, falsifying the context as well as the chronology, and not contradicting Nousaine's highly specific statements at all. It would take an additional page, or more, to include this obviously manipulative "documentation" here, and I refuse to do so.—Ed.]

...Such results [as quoted above] are difficult for those in the Nousaine camp to swallow, for commonly they judge others by what their own ears can hear, or cannot. Always a mistake. Yet one may still enjoy beholding their verbal contortions as they chew the truth about polarity served up by every legitimate researcher on record. Dead to rights,

we have them here: in denial, every one, about a fabulous free fix. Will Tom throw in the towel at last? How about all the audio critics he has helped lead astray? Stay tuned! Find out whether "the muffling distortion" (my term) will later be proclaimed over this same station.

Finally, regarding reader Donald Scott's recent letter dissing the undersigned's "cranky" advocacy of polarity as "the cow chip effect": the errors in his experiment to disprove polarity are so rife and obvious, I must invite the poor soul to write for a free copy of my explanatory book *The Wood Effect*, and that's no bull.

Clark Johnsen
The Listening Studio
Boston, MA

I have made an exception here to my "no further soapbox opportunities for Clark Johnsen" policy as stated in Issue No. 18 because your letter—in which you're up to your usual tricks of creative documentation—provides me with an opportune lead-in to unedited quotations from Lipshitz and Greiner for the benefit of our readers, showing them what these researchers really meant.

The following is an uninterrupted and unedited quotation from S. P. Lipshitz, M. Pockock, and J. Vanderkooy, "On the Audibility of Midrange Phase Distortion in Audio Systems," J. Audio Eng. Soc. 30 (September 1982): 580-95 (your own favorite reference).

...On normal musical material heard via loudspeakers in an average listening room, we have not thus far detected the effect of midrange phase distortions of up to two cascaded all-pass networks of Q 2.2. We do not have evidence to conclusively demonstrate whether phase distortions of this amount can be heard in normal reverberant loudspeaker listening to normal musical or acoustic transients (which are largely oscillatory in nature), but it is clear that the effect, if audible, is extremely subtle.

More work needs to be done in this area, so that transducer designers can make an intelligent decision on the significance (not the existence) of phase effects.

Finally, we wish to caution most strongly against quoting our results out of context. All the effects described can reasonably be classified as subtle. We are *not*, in our present state of knowledge, advocating that phase linear transducers are a requirement for high-quality sound reproduction. More

research is necessary. We do not wish the research outlined above to suffer the same misunderstandings, distortions, and misapplications as have occurred in recent years with transient intermodulation distortion. We feel that listening rooms will become more anechoic as more sophisticated reproduction systems become available. Thus the increased audibility of the phase effects which we have found with headphones may in the future apply also to loudspeaker listening.

So much for what Lipshitz, unfiltered through Johnsen, wants us to understand. As for Greiner, here is an uninterrupted and unedited quotation from R. A. Greiner and D. E. Melton, "A Quest for the Audibility of Polarity," Audio 77 (December 1993): 40-47.

While polarity inversion is not easily heard with normal, complex musical program material, as our large-scale listening tests showed, it is audible in many select and simplified musical settings. Thus, it would seem sensible to keep track of polarity and to play the signal back with the correct polarity to insure the most accurate possible reproduction of the original acoustic waveform.

Authors' Addendum: The work presented here was done in 1991. (It is now September 1993.) Since then, there has been some, but not much, progress made in establishing polarity standards in the recording industry. This work is continuing at the present time. There has been some discussion in hi-fi publications and much anecdotal reporting, in various publications, on the audibility of acoustical polarity inversion. There has been nothing noteworthy in the professional literature, however, that clarifies the issue or "proves" that audibility of polarity inversion is a major factor in listening enjoyment. While it is not clear why this is the case, several factors might be: The difficulty of doing the experiments in a controlled way, as evidenced by this work; the fact that the effect of polarity inversion is small in most program material, or the fact that the effect seems to be small compared to the many other variables in the recording/reproduction processes (microphone use, room acoustics, electronic processing, and the like). Nevertheless, it seems reasonable that at some point another step toward achieving greater audio fidelity will be maintaining polarity of the signals throughout the record/reproduction chain.

To sum up, what Lipshitz and Grein-

er are really telling us is: yes, it's better to pay attention to polarity than to ignore it, but no, it isn't a big deal from a listening point of view. In other words, Clark, the horse you are trying to ride to the higher reaches of the audio world, while a real horse and not a donkey, is a rather slow and somewhat lame mount, unlikely to get you there. Why don't you trade it in?

Lastly, the perpetrator of the phony "triple-blind" listening test (see Issue No. 17, pp. 44 and 47) is in no position to reprimand Donald Scott or anyone else about experimental errors. Get your own act together, Clark, and until you do, please don't write us again. (Maybe you should move to Warsaw, where you could really experience Absolute Polarity.)

—Ed.

The Audio Critic:

.. I have been pleased by the professionalism of your reviews, and I am renewing [my subscription] primarily because I am interested in seeing how your publication evolves with the contributions of your new editors. I have more than enough things to read in my professional life, and I am less interested in rigid publication schedules and first-class mailings than I am in high-quality, analytic criticism. If you were to conduct a reader survey, I would give the following answers:

I became aware of your publication from an ad in *Audio*. I subscribed because I had received a gift subscription to *Stereophile* and I felt that I needed an antidote to the logorrhea and what you refer to as "tweakism." That subscription has now lapsed, and I am continuing with you, partly to understand better which parts, circuits, and features are essential to quality construction and which are not. Most of my equipment was purchased between '77 and '82 and is still performing reliably. I am not "looking for something to buy."

I have followed with some interest the pleas for "tolerance of opposing views" and finding "a halfway ground" of agreement. I am a Radiation Oncologist. I would not recommend any course of therapy without first evaluating prospective double-blind studies. This is how I generate my professional opinions, and I will not give any weight to the opinions of those who do not go through a similar process. Subjectivism in medicine can be deadly. It has no place in any of the physical sciences. Some understand this; some

do not. I do not tolerate unprofessional opinions in my field and would never ask you to do so in yours.

Vincent Capostagno, M.D.
Merced, CA

Readers of The Audio Critic are rather sharply divided into the categories of those who want to learn something (such as you) and those who want to buy something. We try to satisfy both mind-sets; what we refuse to do (although there is a demand for it) is to rattle off a long laundry list of buy-this, don't-buy-that recommendations without documenting the reasons.

I would like to expand on your "some understand this, some do not" observation regarding scientific objectivity. I have come to the tentative conclusion that some have a natural gift for understanding the basic essence of the scientific method, requiring perhaps only a good junior-high-school course in General Science to assimilate the idea, and that others are color-blind or tone-deaf, so to speak, to the scientific mode of thinking, although otherwise intelligent and repeatedly exposed to the best scientific influences. That would explain the immense stubbornness and impenetrability of some far-from-stupid members of the audio community on the subject of "I can hear it" vs. "I can prove I can hear it," when the distinction is obvious to enlightened twelve-year-olds.

—Ed.

* * *

I also want to respond here collectively to a whole bunch of correspondence—long, well-written, laser-printed letters as well as illegibly scribbled, barely coherent ones, both long and short—in which the common theme is audible differences between various pieces of equipment and the common failure is a disregard for the need to eliminate observer bias and the placebo effect. There is no point in publishing any of these letters; we would just be going around in circles, repeating over and over again that without blind listening tests at precisely matched levels all such discussions are meaningless. How many times do we have to reiterate that self-evident precept before it sinks in, without any of these "yes, but" arguments? Or is there anyone out there who actually believes that unmatched levels and peeking at the nameplates will get you closer to the truth? That I can't deal with. •

THE AUDIO CRITIC

In Your Ear



A Moderately Technical Tutorial for the Serious Audiophile

Clock Jitter, D/A Converters, and Sample-Rate Conversion

By Robert W. Adams
Analog Devices, Inc., Wilmington, MA

Forget everything you have read in the "alternative" audio journals on the subject of digital jitter and start from scratch here with the correct scientific foundation.

Foreword by the Tech. Ed.: "The Jitter Game"

I have used the same title for this foreword to an important article on jitter as Stereophile's Robert Harley uses for his articles on jitter, but with a different meaning. Harley is playing a game of pretend engineering when he attempts to analyze the jitter of a CD player and correlate the resultant measurement to the sound quality he perceives. Why does Harley spend so much time on jitter? Because he thinks that it strongly correlates with the sound quality of the equipment. Since open-loop (i.e., nonblind) listening tests are subject to externally originating listener bias, it is easy to see how he can delude himself to arrive at such a conclusion. Stereophile is unfortunately quite influential, and jitter has thus become in the early '90s what TIM (transient intermodulation distortion) was in the late '70s and early '80s.

But Harley has a huge problem because clock jitter cannot be measured directly at the output of a black box. The effects of jitter can be assessed indirectly from black-box measurements, but in a correctly designed CD playback system these effects are commingled with, and usually swamped by, noise and distortion products. Indeed, in exotic designs, the loony-tune analog stages are so riddled with noise and distor-

tion that even large amounts of jitter would have little effect on the measurements. To overcome this problem, Harley plays his little game. He takes off the cover, gets inside the unit, and attempts to measure the jitter on the internal clock line. Now, two problems exist when he does that: (1) since jitter is an internal parameter, its effect on the external performance of the system is dependent on other aspects of the system's design, so it is not possible to compare the measured results directly between two models under test; and (2) measuring clock jitter is a non-trivial task, subject to many errors even when conducted by one skilled in the art.

Note that Harley could continue to play his game and make other measurements while he has the cover open, such as I/V settling time, power-supply rejection ratio, the amount of closed-loop feedback, power-supply output impedance, etc. All these parameters could affect the sound quality, and under Harley's rationale—that being unable to observe the effect of such parameters at the output of the system does not mean they do not affect the sound quality—one could ask why he doesn't make these additional measurements. My contention is that Harley would indeed make these measurements, and then delude him-

self into thinking they were remarkably revealing of sound quality, if some manufacturer delivered to him a test system for a given parameter and showed him step by step how to use it.

Jitter and its effect on the performance an electrical system is a difficult subject, truly understood by only a few experts involved in the design of systems sensitive to jitter. As a result, much misinformation on jitter has been circulated in the press, originating from manufacturers' press releases reproduced without any competent review. In an attempt to clear the air on the subject, we commissioned an article by a genuine expert in the field of digital audio, Robert W. Adams, of Analog Devices, Inc. This article is based on a paper Adams presented at the 95th Convention of the Audio Engineering Society in New York last October. (The preprint number was 3712.) Bob Adams is perhaps the youngest Fellow of the AES (the highest honor awarded in the field of audio engineering), and his many pioneering achievements in digital audio at AD, and before that at dbx, are too numerous to be summarized here. His investigations in the field of jitter reduction have resulted in a new method to attenuate jitter, a practical asynchronous sample-rate converter chip, which is explained in his article. Before this

chip, asynchronous sample-rate converters could be had only at very high prices and in many cases did not perform very well. Since the new Analog Devices ASRC chip is all-digital, it offers the potential for the easier and cheaper implementation of a jitter attenuator than a multiple phase-locked-loop S/PDIF decoder.

As I said, this is not an easy subject, and the article below is not simple. The problem again is that we are trying to explain how an internal system parameter affects the total system performance. If Harley had not made jitter his hobbyhorse, we might not have found it necessary to run such a complex article. But given the current trendiness of jitter in audio journalism, I think it is important that the serious audiophile try to go through the article in order to separate the facts from the fictions the high-end charlatans are trying to legitimize. If nothing else, this article will acquaint you with the complex interrelationships involved in the digital design process. Note that while Bob Adams has simplified as much as was possible without leaving out the essentials, anybody who attempts to measure the performance of an S/PDIF decoder, let alone design one, had better have a much more complete knowledge of the subject. Indeed, it is not possible to read the professional literature in this field without a strong background in signal processing, modulation theory, and random process.

Unfortunately, it is not clear whether Robert Harley understood Adams's AES paper from which the present article is derived. In the January 1994 issue of *Stereophile* he wrote that "the paper stated that a converter's jitter sensitivity is a function of the clock frequency and oversampling rate. This conclusion confirms the validity of our technique of expressing clock jitter as a proportion of the clock frequency." Read Adams's simplified but thorough explanation below and judge for yourself whether that's what he is really saying.

This article does not discuss the S/PDIF encoding and decoding process itself; that discussion is planned for a future issue.

—David Rich

0 Introduction

Although clock jitter has received a great deal of recent attention in the popular audio press, its effect on signal fidelity is poorly understood by most journalists, and many inaccurate statements have appeared in print. The purpose of this article is to introduce the fundamentals of clock jitter and to demonstrate how it actually affects final signal quality for various types of D/A converters.

We also will cover an exciting new development in sample-rate conversion and show how it will influence the next generation of digital audio equipment.

It has become popular practice to measure clock jitter in commercial outboard D/A converters using an FM demodulator attached to the clock pin. The output of the demodulator is fed to a spectrum analyzer, so discrete components present in the jitter waveform may be analyzed. Unfortunately, the amount of degradation a particular jitter spectrum will cause in the output signal depends on the type of D/A converter used. To interpret the results of such a measurement, one has to take into account at least the following significant variables:

(a) Converter type—conventional resistive ladder, sigma-delta, or MASH.

(b) Clock frequency applied to the converter.

(c) Output filter type—switched-capacitor, active RC, or a combination.

(d) Any digital dividers between the measured clock pin and the internal D/A clock rate.

(e) Interpolation ratio.

(f) The frequency and amplitude of the input signal.

(g) Jitter introduced internally to the D/A converter (not measurable except by its effect on the signal itself).

These variables have more than a minor effect on the jitter sensitivity. With the worst combination, phase jitter may have to be lower than 20 ps rms to obtain signals of 16-bit quality, as opposed to more than 1 ns for the best case. Clearly, the relationship between clock jitter and the analog output is complex enough that one should understand the fundamen-

tals before making any judgments based on jitter about the quality of a particular piece of equipment.

Another complicating factor will soon be introduced commercially: a new chip from Analog Devices called an "asynchronous sample-rate converter," rapidly making its way into outboard D/A processors. This chip acts as a universal digital buffer between an input at one sample rate and an output at any other sample rate. As a byproduct of the algorithm employed in the chip, jitter on either the input or output sample clocks is largely eliminated. While most engineers understand how a conventional analog PLL may be used to remove clock jitter, it is not obvious how an all-digital sample-rate converter can accomplish the same task. Later in this article we will discuss how use of this chip affects jitter in D/A converters.

1 Review of Clock Jitter

Clock jitter may be defined as the time displacement of a clock signal relative to an ideal clock signal with no jitter. Note that all the information about jitter is contained in the edges of the clock signal, and it is common to specify jitter in the time domain as either the p-p or rms deviation of any edge from its ideal position over many thousands of clock cycles. Most digital systems will change state only on one edge of the clock signal (the rising or falling edge), in which case the jitter is measured on the clock edge to which the system responds.

In practical systems, the common types of clock jitter are:

(a) Random variations in the arrival of clock edges relative to their ideal positions. For advanced readers, this type of jitter is referred to as white phase jitter, as it may be produced by feeding a random-noise (i.e., white-noise) signal into a phase-controlled oscillator.

(b) Random variations of the width of a clock pulse. This type of jitter differs from (a) in that each edge is referenced to the previous edge rather than to a hypothetical ideal clock signal. Again, for E.E. types, this jitter is referred to as white FM jitter, as it can be produced by feeding a white-noise signal into a

frequency-controlled clock generator.

(c) Correlated variations in the clock edge events relative to an ideal clock. By correlated we mean that the instantaneous time displacement measured on each clock edge is not an independent event but is in some way related to previous clock edge times. For the technical reader: this causes a jitter "spectrum" which is nonwhite and may have spectral peaks at particular frequencies. We will refer to this type of jitter as correlated jitter. If the variation in clock frequency is "slow" compared with audio frequencies, we will call this low-frequency correlated jitter; if these variations are fast compared with the audio spectrum, we will call this high-frequency correlated jitter.

2 The Pitfalls of Time-Domain Measurements

It is common to estimate clock jitter by using an oscilloscope with a very accurate time base. This practice is dangerous, as the results obtained depend on the type of jitter as well as on the measurement technique. It also is often the case that the oscilloscope used will have more jitter in its time base than is present in the clock itself. Advanced instruments are available to make accurate measurements of jitter but are not used enough.

Figure 1 shows one measurement technique where an oscilloscope is set to trigger on a clock edge and the time base is set so that only the next edge is visible on the scope. The variations in the arrival time of the later edge can be used as a measure of p-p jitter. More sophisticated oscilloscopes can plot a histogram of zero-crossings, allowing a more accurate estimate of the rms jitter without resorting to "eyeball" measurements.

Since we are triggering on one edge and measuring the arrival time of the next, we are assuming that the first edge (the one we are triggering on) is in its "ideal" time position. This technique is fine if we are measuring white phase jitter as defined above, where the errors in the clock edge positions do not accumulate over time relative to an ideal clock signal. But suppose that the frequency of the clock signal is slowly wandering by a small amount (low-

frequency correlated jitter). This slow wandering of the frequency causes large displacements of the clock edges relative to a stable clock, but the edge-to-edge measurement technique will not reveal this effect, as each measurement is made in reference to the last clock edge only.

Another common technique is to trigger an oscilloscope on a clock edge and, by using the delayed trigger feature, examine the edges that occur at some later time (for example, 10 clock edges later). See Figure 2. If we assume that, again, we have a clock signal with slowly varying frequency, we can see that this measurement technique will start to reveal this low-frequency jitter component as long as the trigger delay is long enough for the frequency of the clock signal to have changed substantially between the moment when the trigger event occurred and when the delayed edge is examined some time later. But one danger of this technique is that it is possible the jitter frequency is correlated in such a way that at particular trigger-delay values the delayed edge of the clock has returned to its correct position. This technique therefore has periodic occurrences of "blind spots" relative to the modulating frequency of the clock generator and is not to be trusted if the clock signal contains highly correlated jitter components.

The predominant type of noise mechanism present may be estimated by examining a succession of delayed edges and observing how the jitter behaves as a function of delay time. White FM jitter as defined above will display a square-root relationship between delay time and observed edge jitter, as each clock period is an independent jitter event, and therefore many such events add in rms fashion. Jitter which contains low-frequency modulation of its frequency will show a linear relationship between delay time and observed jitter. White phase jitter shows no increase in observed jitter with trigger delay time, as the errors do not accumulate over time. Correlated jitter shows a more complicated relationship between edge-to-delayed-edge delay times and observed jitter.

The discussion above indicates that time-domain jitter measurements

are dangerous, although useful information may still be obtained if one is careful. It is preferable nonetheless to use a high-quality FM or PM detector in conjunction with a spectrum analyzer, provided one knows how to interpret the results [Robbins 1982].

3 Sources of Jitter in Practical Clock Circuits

Consider the clock circuit of Figure 3, which is a typical RC oscillator, such as might be found in the voltage-controlled oscillator used in a PLL. The VCO works in the following fashion. Assume at the outset that the capacitor is charged to V_{ref} Low and the logic has turned on the switch which connects the current source I_{up} to the capacitor. The voltage on the capacitor now rises with a slope proportional to I_{up} . When the voltage on the capacitor reaches V_{ref} Hi, the upper comparator changes state and the current I_{down} is now connected to the capacitor, causing the capacitor to begin charging down at a rate proportional to the current. When the voltage reaches V_{ref} Low, the lower comparator changes state, and the whole operation repeats itself, forming an oscillator.

From the previous explanation, we can see that the current I determines the frequency of oscillation of the oscillator.

There are at least three possible sources of jitter in this circuit. Here we are analyzing only the one caused by thermal noise. Practical effects such as correlated frequency components on the power supply or those picked up because of magnetic coupling will of course be added.

The first source of error is noise in the current that charges and discharges the timing capacitor C_1 . Since this current directly controls the frequency of the oscillator, noise on this current source translates directly into white FM clock jitter.

The second source of error is thermal noise at each comparator input, which causes the comparator to switch at the wrong time. Since each pulse is referenced to the end of the last pulse, any variation in clock arrival time will be "remembered" by all subsequent pulses, and therefore this mechanism must again produce white FM jitter. This can be verified

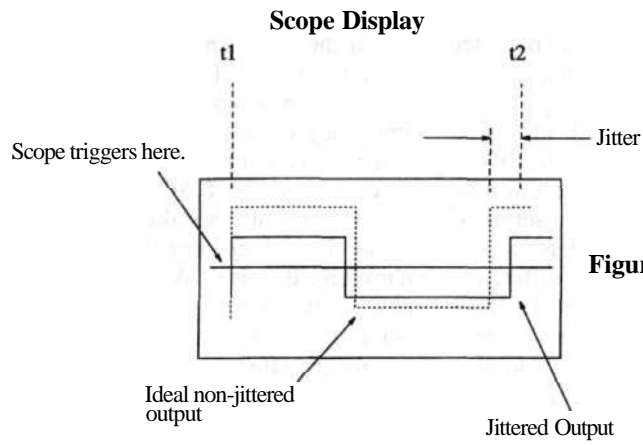

Figure 1: Edge-to-edge jitter measurement.

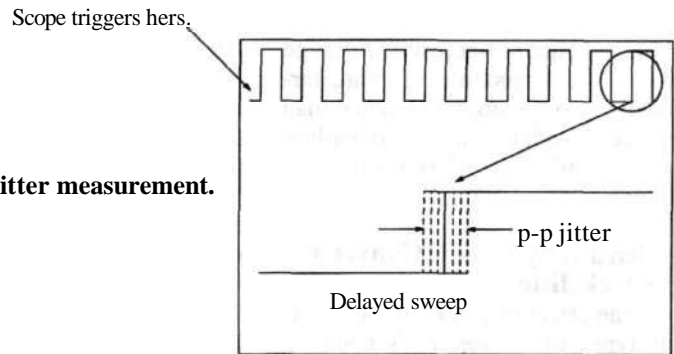

Figure 2: Edge-to-delayed-edge jitter measurement.

Scope Display

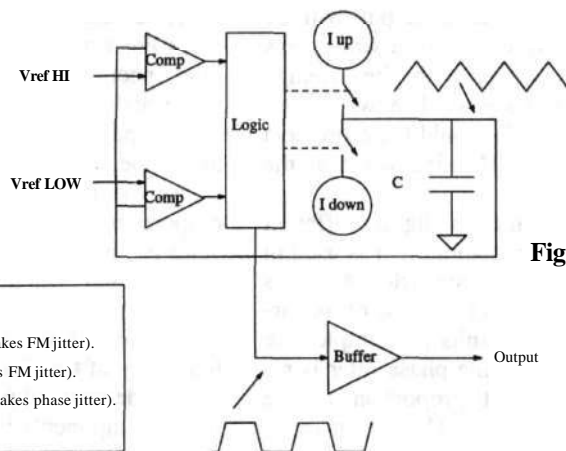

Figure 3: Jitter sources in a typical RC oscillator.

Jitter Sources:

- 1) Current source noise (makes FM jitter).
- 2) Comparator noise (makes FM jitter).
- 3) Buffer intercept noise (makes phase jitter).

by imagining that the comparator noise is dc (equivalent to an offset). It is easily seen that this causes a shift in frequency.

The third source of error results from thermal noise on logic gates that are fed with finite rise-time clock signals. Such noise on the inputs of these gates is translated into jitter from the delta-t to delta-v conversion that occurs due to the finite rise time of the input signal. Since this mechanism has no "memory," it results in white phase jitter.

There are several other types of oscillators that offer improved jitter performance. Crystal-controlled oscillators are best. Voltage-controlled crystal oscillators are available, and these are sometimes used to recover the clock from the incoming serial data stream (from the output of a CD player, for example). While they have low jitter, they suffer from a limited frequency-adjustment range (about 0.1% maximum). Varactor-tuned LC oscillators are better than the RC oscillator described earlier, but not nearly as good as a crystal oscillator.

4 Sensitivity of D/A Converters to Clock Jitter

The effect of clock jitter on various types of converters is complex and depends on many factors. Converter topologies may vary in their sensitivity to jitter by several orders of magnitude, depending on the nature of the jitter.

For the purposes of analyzing jitter sensitivity, D/A converter fall into three classes.

(a) Conventional, resistive ladder converters with or without interpolation filters.

(b) Sigma-delta converters with continuous-time output filters.

(c) Sigma-delta converters with switched-capacitor output filters.

4(a) Conventional, resistive ladder D/A converters:

The effect of jitter on the output of a D/A converter can be analyzed by subtracting the output of a D/A converter that uses a jittered clock from the output a theoretically perfect converter that uses a nonjittered clock, and then looking at this difference in the time domain. Figure 4

shows this analysis technique for the case of a conventional D/A converter with two different input frequencies and no interpolation filter.

Figure 4a shows a 1 kHz sine wave sampled at 50 kHz. The difference between jittered and nonjittered D/A outputs is seen to be a series of narrow spikes whose width is proportional to the instantaneous difference between the arrival time of the ideal clock and that of the actual jittered clock, and whose height is proportional to the change in signal amplitude from the previous to the current sample. Here we show the case for white phase jitter, which does not accumulate over time. Note the modulation of the error spikes by the signal slope, which causes the error to become very small at the signal peaks.

We are now in a position to analyze the added noise and how it relates to the signal. The spectrum will be white, as there is no statistical relationship between one error pulse and the next. The rms amplitude of the noise spectrum is related to the average slope of the DAC output signal, as large step sizes between adjacent samples cause large error pulses in the error signal. This fact can be seen clearly in Figure 4b, where a higher-frequency signal (6 kHz) has been applied to the D/A converter, resulting in larger step sizes between adjacent samples and hence larger error pulses.

We can summarize by saying that for white phase modulation of the clock, the D/A output will be corrupted by white noise whose rms amplitude varies with the average slope of the signal. The worst-case signal for audio would therefore be a full-scale 20 kHz sine wave at the D/A output.

The situation is slightly different when an interpolation filter is used in front of the D/A converter. Analysis of that is beyond the scope of this article, but the results are simple: the sensitivity to white phase jitter is reduced in direct proportion to the oversampling ratio. This means that a D/A converter using a 16x interpolation chip will be four times less sensitive to jitter than one using a 4x oversampling filter (assuming that the absolute jitter in ps is the same

for both clocks).

If the jitter is not white phase jitter but rather a relatively slow variation of the clock frequency (low-frequency correlated jitter), then the situation is quite different. Assume that we feed the DAC with a sine wave. Spectrally speaking, a slowly wandering clock signal will cause narrowband noise "skirts" to appear around the frequency of the sine wave signal. Oversampling no longer has much effect on the output spectrum, as the errors introduced by the clock modulation are all "inband" (below 20 kHz).

Many types of jitter fall in between the pure white phase jitter and slow frequency-variation type of jitter described above. In that case, oversampling may improve the jitter sensitivity to a certain degree, but not as much as in the case of truly random white phase jitter. Jitter in which the time base is sinusoidally modulated will potentially produce discrete frequency components spaced around spectral sticks in the DAC output signal.

For resistive ladder converters, it is obvious that with no input signal (or dc), jitter cannot have any effect on the output. The output is not changing, so it doesn't matter exactly when it doesn't change! While this observation may seem trivial, the same statement cannot be made for other types of converters, as we shall see presently.

In summary, regarding resistive ladder D/A converters, we can state the following:

- For white phase clock jitter, the jitter spectrum on the DAC output is white and proportional to the average of the absolute value of the signal slope. Oversampling filters decrease the jitter sensitivity in direct proportion to the oversampling ratio. With no input to the DAC, jitter has no effect and does not raise the noise floor.

- For "slow" variations in the frequency of the clock signal, narrow noise sidebands appear around sinusoidal components in the D/A output spectrum, again with an amplitude proportional to the frequency and amplitude of the sinusoid. Oversampling filters do not decrease the jitter sensitivity in this case.

Figure 4

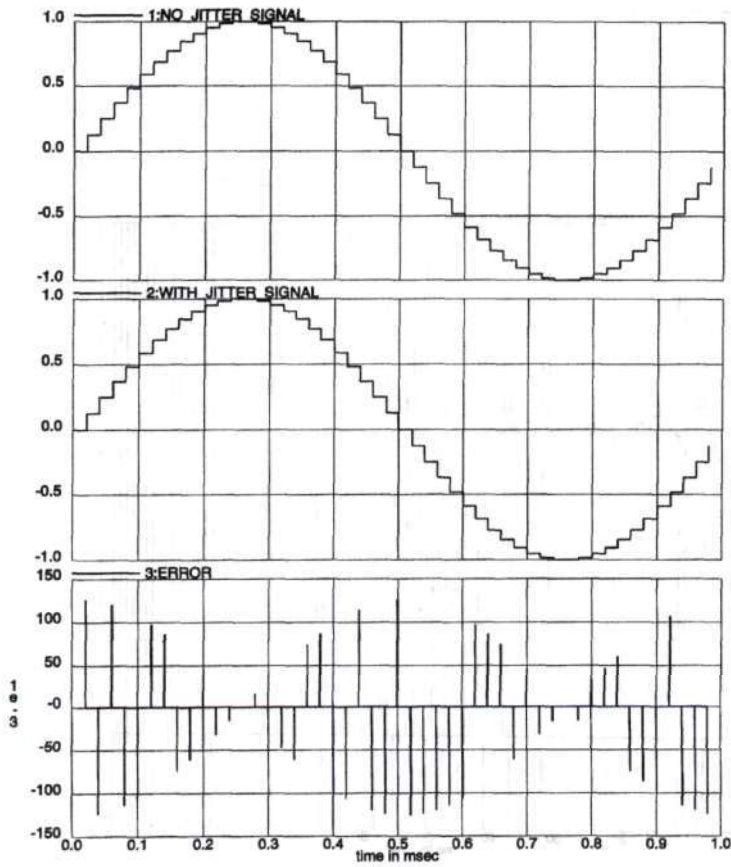
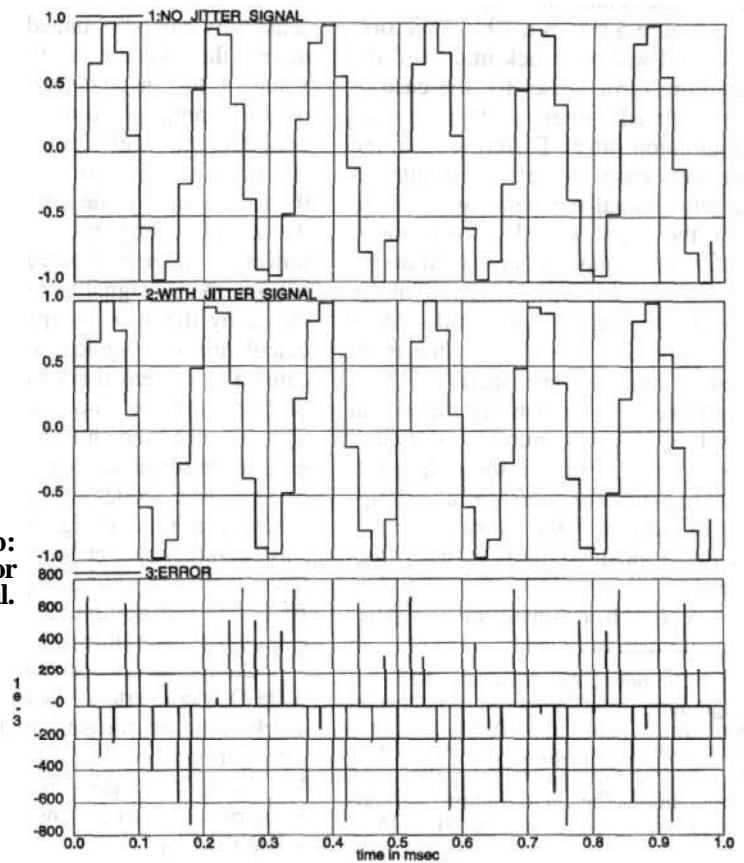

Figure 4a:
Time-domain jitter error
for a 1 kHz signal.

Figure 4b:
Time-domain jitter error
for a 6 kHz signal.



4(b) One-Bit Noise-Shaping D/A Converters with No Switched-Cap Output Filter

This type of converter has become very popular in recent years, both because of its inherent linearity and because it can be implemented in an all-digital CMOS process.

One-bit noise-shaping converters can be further divided into two classes. The first is a single-loop modulator with 1-bit quantization, and this 1-bit signal is fed directly to a 1-bit output stage at the modulator clock rate. The second class of converters, so-called MASH converters, involve multiple loops with feedforward noise cancellation. They internally produce a multiple-level digital signal, which is converted to a 1-bit signal through digital pulse-width modulation. To achieve the desired time resolution for the digital pulse-width modulator, a clock signal with a very high frequency is typically used.¹

In the previous section, we saw that the sensitivity to clock jitter was proportional to the changes in the DAC output from one sample to the next. For 1-bit converters, this "change" is always full-scale, regardless of the actual input signal!

Figure 5 shows a 1-bit waveform with and without clock jitter, and the resulting error pulse, for the case of uncorrelated jitter (white phase-modulation jitter). Differing from the previous case, the effect of jitter is largely signal-independent, and in fact the input signal to the noise-shaper loop may be zero with no reduction in jitter sensitivity. This is because the modulator is still switching vigorously even when the input is zero. In some cases there may be a slight reverse sensitivity to signal amplitude, as the number of transitions per unit time in the output bit-stream generally decreases as the signal approaches the maximum level in either positive or negative directions.

A rough estimate of the jitter

¹The new DAC devices of NPC use single-loop modulators with multilevel quantizers. As in the MASH devices, the multilevel digital signal is converted to a 1-bit signal through digital pulse-width modulation. The new Philips-designed \$400 Marantz CD-63 uses an NPC DAC.

—David Rich

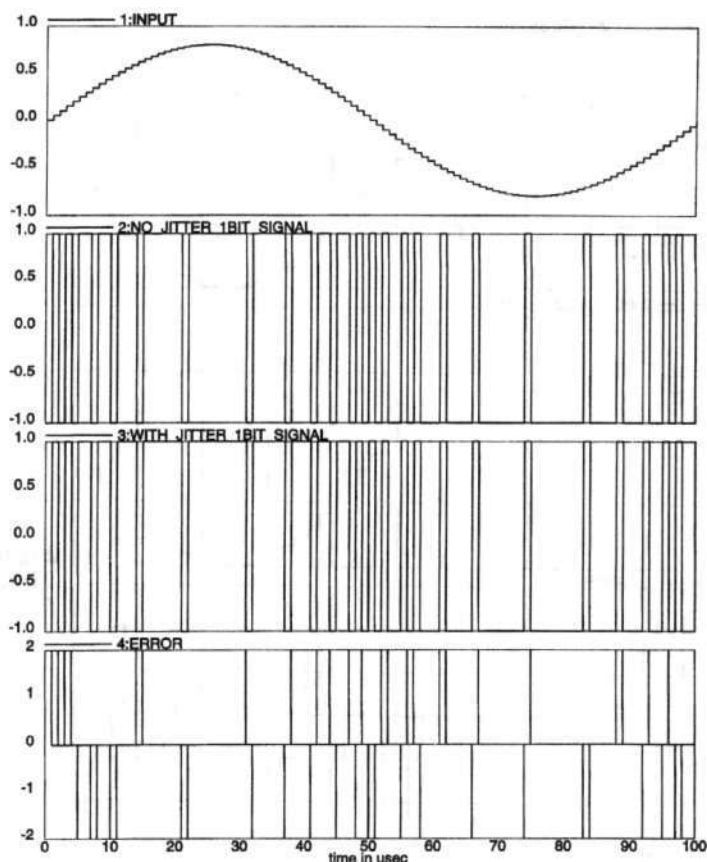

Figure 5: Time-domain jitter waveforms for 1-bit D/A converters.

sensitivity can be obtained simply by taking the average of the absolute value of the instantaneous jitter (in ps, for example) and dividing by the period of the high-frequency clock that drives the 1-bit output stage, and then dividing by the square root of the oversampling ratio. This noise power is then compared with the maximum rms signal that can be produced by the 1-bit output. A quick calculation of a typical system indicates a jitter sensitivity on the order of 20 ps rms for 16-bit performance! This is more than an order of magnitude more sensitive than for the case of resistive ladder converters. It is far from trivial to design an oscillator this good; only crystal oscillators have a chance of meeting the spec. Elaborate test equipment is required even to measure jitter as low as this.

Comparing two different sigma-delta D/A converters having different clock rates by measuring the clock jitter for each converter is not trivial. For example, suppose that the output stage of converter A runs at 12 MHz while the output stage of converter B

runs at 6 MHz (half the rate of A). Also assume that both clocks are divided down from a common 24 MHz master clock signal with a certain amount of white phase jitter. Note that the absolute jitter in ps is the same for both the 6 MHz clock and the 12 MHz clock, as a digital divider will maintain the absolute edge positions of the master clock on its divided outputs. The noise produced by each converter as a result of jitter is proportional not only to the amount of white phase jitter but also to how often it occurs. As a result, the converter running at the 12 MHz rate will produce 3 dB more total noise than the one running at 6 MHz (recall that each edge displacement is an independent statistical event, and therefore the rms noise increases by 3 dB for each doubling of the number of error events). However, the noise produced by converter B is spread over twice the bandwidth as that produced by converter A, and therefore the two converters produce the same amount of inband noise.

This analysis applies *only* to 1-

THE AUDIO CRITIC

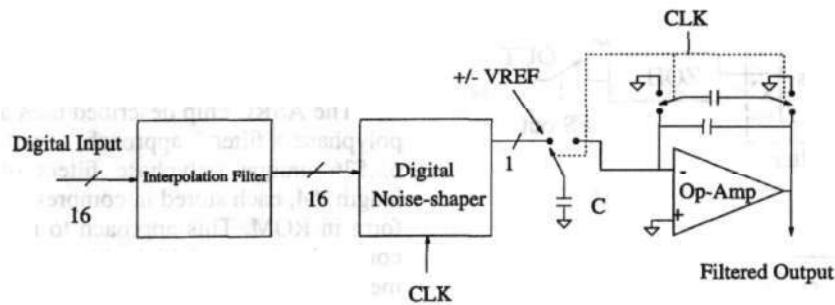

Figure 6: Sigma-delta converter with switched-capacitor filter.

bit output DACs. If we apply the same experimental setup as before to a conventional interpolated R - $2R$ DAC, we do not get the same results. This is because the DAC that operates at the higher-frequency clock rate is more highly interpolated, causing the sample-to-sample differences between one output sample and the next to decrease in direct proportion to the oversampling ratio. As a result, the DAC operating at the higher clock rate would show 6 dB less inband noise than the same DAC running at half the clock frequency. This result is different from the 1-bit result because for a sigma-delta output stage, the sample-to-sample transitions are always full-scale, regardless of the clock rate or interpolation ratio.

It is clear from this analysis that 1-bit converters are very sensitive to white phase modulation of the clock. This can be explained in the frequency domain by the observation that phase modulation causes the out-of-band shaped noise to "fold" down into the baseband. In the time domain, it is intuitively clear that the edge-to-edge jitter is what affects this type of converter the most. Low-frequency correlated jitter of the clock is not nearly as damaging to the noise performance of the DAC, although correlated sidebands around the signal may become a problem.

One interesting aspect of this high jitter sensitivity is that it is difficult for manufacturers using this type of D/A converter to meet the high dynamic-range specs common with today's equipment. For example, in a system that uses a conventional, resistive ladder D/A converter, the noise is measured with no digital codes toggling, and therefore is determined only by analog thermal circuit noise, which may be much

lower than theoretical 16-bit quantization noise (this figure of course is not meaningful, as the noise will increase as soon as the music begins). Clock jitter has absolutely no effect under these conditions. But in a system with a 1-bit sigma-delta or MASH converter, the 1-bit signal is very "busy" even when the digital input signal is silent. Clock jitter will most likely be the dominant noise source, and therefore it will be difficult for the manufacturer to claim 110 dB of dynamic range. In some cases an extra circuit is used to detect "digital silence" and the 1-bit D/A output stream is actually turned off under these conditions to make the numbers look good!

In conclusion, 1-bit D/A converters with no discrete-time output filters are extraordinarily sensitive to edge-to-edge jitter caused by white phase modulation of the clock. As we saw before, such phase modulation often is caused by passing a clock with finite rise time through a buffer. One must be very careful to reduce this edge-to-edge type of jitter to the lowest levels possible.

4(c) One-Bit Noise-Shaping D/A Converters with Switched-Cap Output Filtering

Figure 6 shows a block diagram of a D/A converter with switched-cap output filter. The origin of the name "switched-capacitor filter" is obvious from the diagram. The switching of the capacitor removes its memory characteristic. A first-order analysis of a switched capacitor shows that it is equivalent to a resistor of value $1/fC$, where f is the frequency at which the switches change state. In an integrated circuit, the exact value of a resistor or capacitor can vary by 30% or more. This makes the design

of precision RC filters impossible. The transfer function of a switched-cap filter is dependent on the ratio of capacitors, which can be controlled to 0.1% in an integrated circuit. In Figure 6 we see two switched-capacitor circuits that replace resistors in a continuous-time circuit. If we replace the switched-cap circuits with resistors, we can see that the filter in Figure 6 is a first-order low-pass.

A more exact analysis of a switched-capacitor circuit is required to take into account the sampling effect of the switch. This more exact analysis shows that a switched-cap filter must be analyzed as a discrete-time system in much the same manner as a digital filter. It is often a point of great confusion how a switched-cap output filter is different from a continuous-time active RC filter when it comes to jitter. The answer is as follows. A switched-cap filter will settle to a particular value regardless of when the clock edge occurs (assuming the op-amp is fast enough to settle completely within one switching interval). It is a true discrete-time system in that the dynamic settling behavior of all circuit voltages is not important as long as the settled value is correct. This is not true for the case of a 1-bit modulator feeding a continuous-time filter, where an error in the switching time of the 1-bit signal does have an effect on the voltage at the end of the clock period, and in fact will change the output voltage for many hundreds of cycles thereafter.

From this discussion we can conclude that a 1-bit modulator feeding a switched-cap filter behaves the same as a resistive-ladder converter running at the same oversampling ratio, as both converters produce voltages that settle to the same value regardless of the timing of the clock edge. This is true as long as the switched-cap filter completely removes the out-of-band noise from the 1-bit modulator. If that's not the case, then the jitter sensitivity depends on the sample-to-sample differential change. If the change is dominated by the signal slope itself, then the jitter sensitivity is unchanged from the case where the out-of-band noise is completely re-

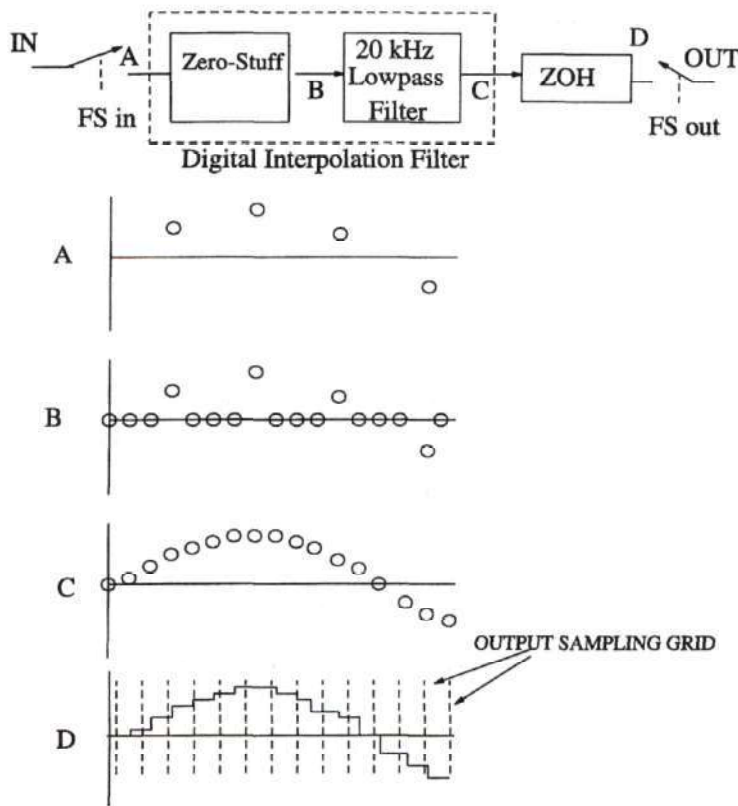

Figure 7: Time-domain view of sample-rate conversion.

moved. If the sample-to-sample change is dominated by unfiltered out-of-band noise, then the jitter sensitivity will be in proportion to the rms value of the sample-to-sample changes. Note that in cases where a switched-cap filter is followed by a continuous-time analog filter to reduce further the out-of-band noise, only the switched-cap filter is useful for reducing the sensitivity to jitter. This fact implies that it is impossible to predict the jitter sensitivity of a chip-level D/A converter that has

²The Crystal CS4303, Burr-Brown PCM67, all MASH chips, and all NPC chips use continuous-time filters. An application note available from Crystal Semiconductor on the CS4303 shows how difficult it is to create the required low-jitter clock. The Crystal CS4328 uses a fourth-order switched-capacitor filter for removal of most of the out-of-band energy. It is followed by a second-order continuous-time reconstruction filter which removes most of the image signals that arise from the switch sampling of the switched-cap filter. The Philips 1-bit DACs are a hybrid. They use an on-chip first-order switched-cap filter (similar to that in Figure 6), which removes some of the out-of-band energy. This is followed by an off-chip continuous-time filter.

—David Rich

both switched-cap and continuous-time RC filters onboard, as it is impossible to tell how much of the filtering is done in each section.²

5 Asynchronous Sample-Rate Converters (ASRC) and Jitter Reduction

In a previous paper [Adams and Kwan 1993] I described an algorithm and VLSI implementation of it which allow sample-rate conversion between arbitrary asynchronous rates. Unlike synchronous converters, the device accepts external clocks at $F_{S_{in}}$ and $F_{S_{out}}$, and by performing various signal-processing operations on those clocks it is able to derive a high-accuracy estimate of the current sample-rate ratio, and this estimate is continuously updated so as to track real-time variations in the input or output sample rates.

Figure 7 shows a time-domain view of sample-rate conversion. Conceptually, asynchronous conversion consists of interpolating the input sequence to an extremely high frequency, which causes the amplitude differences between adjacent interpolated samples to become very small.

The output resampling process then consists of picking off the nearest interpolated point.

The ASRC chip described uses a polyphase filter approach, with 65,536 unique polyphase filters of length 64, each stored in compressed form in ROM. This approach to rate conversion is more efficient to implement than the interpolation/decimation model, as unneeded interpolated outputs are not computed. While polyphase filtering sounds complicated, it is actually quite a simple concept.

Every FIR filter has a particular group delay, which defines how much delay the filter introduces to signals appearing on its input. A typical interpolation filter might exhibit about 600 μ s of group delay, for example. Most FIR filter are designed to be linear-phase, which means that the delay introduced by the filter is independent of frequency.

Normal linear-phase FIR filters have a group delay that corresponds to an integral number of clock cycles. But it also is possible to design an FIR filter which is linear-phase but has a group delay of an integer plus a fractional number of clock cycles. For example, a normal FIR filter of length 100 taps might have a group delay of 50 samples (half its length). But it is possible to design a linear-phase FIR filter with a group delay of 50.5 samples. Now suppose that we had a large bank of FIR filters all connected to the same input signal, and each of these filters had the same frequency response but a slightly different group delay. When we change the sample rate of a signal, we are effectively attempting to resample the signal at a point between the existing sampled points of the input signal. Using the filter bank described, we could simply pick a filter output whose delay matched most closely the desired resampling point for that particular output sample. For example, if the output clock signal (which differs in frequency from the input clock signal) were to fall halfway between two edges of the input clock signal, we would select the filter that has a group delay of 50.5 input sample periods.

To ensure that we have enough possible group delays to select from, the new AD 1890 chip uses a bank of

65,536 possible filters. Depending on the internally calculated, desired output-resampling point, one of these 65,536 possible sets of coefficients is selected to weight the surrounding input data values to produce an output point.

By using such a large number of possible group delays, the error introduced by the time quantization in the resampling process is about at the 16-bit level for the "worst-case" signal, which is a full-scale 20 kHz input signal. For lower amplitudes and/or frequencies, the error is significantly less and is ultimately limited by the stopband rejection of the polyphase filters.

The algorithm used in this chip is quite complex, and interested readers are referred to AES Preprint 3712 for details. At the heart of the chip lies a circuit that computes an internal estimate of the ratio of input to output sample frequencies. This computation is done continuously, and in fact will track real-time changes in sample rates that are quite rapid. The interesting part of this chip from the perspective of rejecting jitter lies in the fact that this internal estimate of the frequency ratio is computed using thousands of past input- and output-sample clock events, and is therefore immune to small perturbations in the arrival time of any individual clock edge. This jitter-rejection capability may be thought of as a filter where the cutoff frequency is as low as 3 Hz. Any jitter components above 3 Hz are filtered with a lowpass characteristic of -6 dB/octave. For example, a 100 Hz jitter component is 5 octaves above 3 Hz, and will be attenuated by 30 dB. Higher-frequency jitter, naturally, will be attenuated even more.

This ability to reject jitter suggests an interesting system architecture for outboard D/A converters. Normally, they must recover a low-jitter clock from the incoming serial bitstream. Typical integrated S/PDIF receivers have PLLs with relatively poor jitter-rejection capability, and even if the original S/PDIF signal is of good quality, by the time it has traveled through several feet of cable it may have high jitter due to the intersymbol interference caused by the finite bandwidth of the cable. That

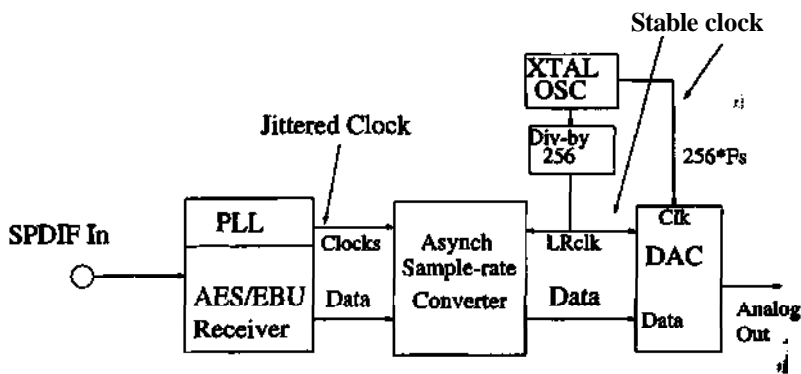

Figure 8: Outboard D/A processor with sample-rate converter.

makes it difficult for the circuit designer to provide a stable low-jitter clock to the D/A converter chip.

Figure 8 shows a system where a sample-rate converter is used between the clock-recovery and S/PDIF receiver chip and the D/A converter. Note that since the input and output sample frequencies are decoupled, the designer can use a crystal oscillator to provide a low-jitter clock to both the D/A converter and the output side of the sample-rate converter. The sample-rate converter will prevent the input jitter from affecting the output data, and the D/A converter is allowed to operate with a crystal clock signal. Note also that the sample-rate converter will reject jitter on its output clock as well, in that the output data will not be affected by the jitter. But if this jittered clock is used to clock the D/A chip, then errors will still arise in the D/A converter itself.

Evidently such ideas are confusing, as conceptual errors have already appeared in print. Suppose that one measures the jitter at the D/A converter clock pin both with and without the sample-rate converter being used. Suppose that without the sample-rate converter, the jitter is measured to be 1 ns rms. In this case we are measuring the jitter of the PLL used in the clock-recovery circuit of the S/PDIF receiver. Now we measure the same D/A clock pin using the sample-rate converter, and we find that the jitter is measured to be 100 ps. One might be inclined to state that the sample-rate converter chip has reduced the jitter from 1 ns to 100 ps. But this misses an important point: the sample-rate converter does not produce an output clock;

rather, it *accepts* whatever clock the user feeds to it. The reduction in jitter follows because the designer is free to supply a crystal-generated clock signal to the D/A converter, and this clock can be as clean as he or she can make it. In fact, even with the world's worst sample-rate converter, as long as it was asynchronous the clock jitter measured at the D/A converter would be that of the crystal oscillator itself.

How, then, can we judge the quality of the sample-rate conversion? There is no clock signal produced by the sample-rate converter chip that can be measured (it does not even exist internally!). The only way to judge the signal quality is to look at the signal itself. Since the jitter is filtered to about 3 Hz with the sample-rate converter chip, it should be possible to "zoom in" on a sine-wave test tone using an extremely long FFT (or a slow-sweeping analog spectrum analyzer connected to the D/A output) and see very narrow noise "skirts" around it. These are in fact visible if you have test equipment good enough to resolve such narrow sidebands. Note that these sidebands are *much* narrower and lower in energy than the narrowband noise-modulation products in such bit-rate reduction schemes as DCC and MiniDisc, so they will not be audible.

To demonstrate the jitter-rejection capability of this chip, we have constructed an artificially severe test where both the input and output clocks are jittered with 100 ns p-p binomial-distributed jitter (produced by feeding a random binomial bitstream into an RC oscillator). Notice that the degradation consists entirely

of noise tails around the fundamental frequency (see Figure 9). This obviously is an exaggerated case, designed to make the noise sidebands readily visible. Normal amounts of jitter cause much smaller amounts of narrowband noise modulation, and in most cases extremely long FFTs are required to measure it with any accuracy.

6 Recommended Measurement Practice

In view of the expertise required to interpret D/A clock-jitter measurements, reviewers should stay focused on the signal and not try to infer signal degradation from jitter measurements. I propose the following measurements, which would be particularly sensitive.

6(a) Noise Modulation with a Full-Scale 20 kHz Sine Wave

This test is easy. Using a spectrum analyzer and a notch filter, apply a full-scale 20 kHz test signal to the D/A converter in question. Measure the increase in the broadband noise level, ignoring spectral distortion components. Note that sigma-delta or MASH converters with no switched-cap output filters will not be stressed by this test, as the slope of the signal at the discrete-time/continuous-time boundary is dominated by the shaped quantization noise and not the signal. This test will particularly stress conventional, resistive ladder DACs that use low oversampling ratios (4x, for example).

6(b) Narrowband Noise Modulation

This test should reveal low-frequency jitter components. I would define this as the difference between a THD + N test made with a normal-width notch filter and the same test done with a very narrow notch filter (say, 50 Hz) using an input frequency of 5 kHz or so. The problem with this test is that it will not have any psychoacoustic relevance, as narrowband noise components will be masked. It is of technical interest only, as an aid to the design engineer.

6(c) Correlated Jitter

This test simply looks for frequency components that seem to fol-

low the frequency of the input signal with a particular offset. For example, if distortion components were noted at 800, 900, 1100, and 1200 Hz with an input signal of 1 kHz, we could infer that 100 Hz FM was present in the clock signal, especially if the same relative spacing was observed as the input signal was increased to, say, 2 kHz. This can be a tricky measurement to interpret, as other problems may produce the same spectrum (for example, a small amount of 1 kHz and 2 kHz signal appearing on the D/A reference pin, causing AM, which is difficult to distinguish from FM). It is also possible that some FM components may be higher in frequency than the "carrier" (input signal) and may therefore alias, causing patterns that are difficult to interpret. Still another potential problem is that the jitter frequency may be related to the signal itself (for example, coupling of the MSB into oscillator circuits), and therefore the fixed-offset relationship mentioned earlier between the signal and its distortion components may fail to appear. Note that very low-frequency clock FM is apt not to show up in traditional THD + N measurements, as the width of the notch filter commonly employed is usually large enough to attenuate the sidebands as well as the main signal. Again, one can point out that low-frequency jitter is not important

when it falls within a critical band.

Comments

Traditional THD + N versus frequency tests and FFT spectrum plots for input signals of various frequencies are adequate to cover the effects caused by jitter. There is no reason to single out distortion components caused by jitter as distinct from those caused by such other effects as D/A nonlinearity, op-amp distortion, etc., the only possible exception being the broadband noise-modulation test mentioned above. A full-scale 15 kHz or 20 kHz tone will have no masking for frequencies in the 1-5 kHz range, and for those very rare audio signals with most of their energy in the last half-octave, it is possible that, if excessive jitter is present, noise modulation might be audible at very high playback levels. A high-frequency THD + N measurement may not adequately show this noise modulation if the residual distortion signal is dominated by discrete harmonic distortion. On the other hand, if the THD + N at 20 kHz shows little or no rise compared with the same measurement at 1 kHz, jitter is not a problem.

7 Conclusion

Any signal degradation caused by using jittered clocks to drive D/A converters is a complex combination
(continued on page 33)

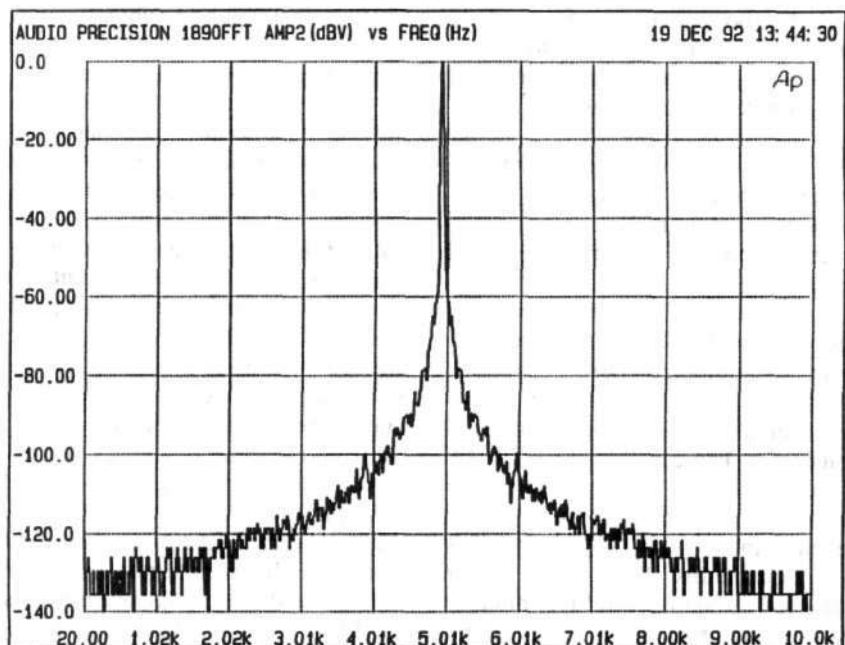

Figure 9: FFT with 100 ns p-p binomial jitter on the L/R clock.

Loudspeaker Systems Using Forward-Firing Cones and Domes: How Good Can They Get?

By Peter Aczel
Editor and Publisher

As drivers, designers, and system design software become more and more sophisticated, the sound improves—but how much? We tested a number of interesting new speakers to explore the answer.

It has become a truism—tweako cultists to the contrary notwithstanding—that switching to a significantly better loudspeaker will improve your sound more than any change in electronic components, regardless of cost. This publication is one of the most fervent advocates of that tenet.

Even so, if you already own a fine forward-firing dynamic speaker system—let us say one of the higher-priced models by Snell, B&W, Fried, or anything else of that order—do not imagine that your audio life will dramatically change if you switch to the latest and most highly refined system of the same basic architecture. There are no miracles in electroacoustics—if the music comes out of 1-inch and 6-inch and 12-inch holes, it will invariably sound more constricted than it would in Carnegie Hall, even if those holes are exceedingly transparent. If that sounds like an indirect endorsement of large planar and line-source speakers, so be it—but that approach has its own goblins and demons. If I were a record producer and wanted to monitor a new recording in progress, I think I would still opt for the most accurate forward-firing dynamic speaker I could lay my hands on. The truth—what do I *really* have on my tape?—is more likely to be told by such a speaker. But for home listening, strictly for pleasure? I'm still not sure.

My vacillation is rather strikingly exemplified by the **DCM Time Window Seven**, which I reviewed in the last issue and which quite successfully splits the difference between a forward-firing monitor and a multiple-wave-launch bi- or omnidirectional type of design. It sounds bigger and more room-filling, though perhaps a bit less precise, than the former but more focused and sharply delineated than the latter, yet almost as expansive and 3-D. I have become quite addicted to it and now recommend it even more highly than I did before.

Anyway, perfecting the standard, conventional formats is always a most important part of technological progress, and the speaker systems reviewed below are

some of the best recent examples of that endeavor. The "monkey coffin," as the old-time salesmen used to call the classic forward-firing box speaker, has come a long way.

Indeed, with each new generation of speakers and each small improvement, we are probably not far from the point where double-blind comparisons at matched levels will be needed to evaluate and rank some of the more similar designs. As amplifierlike accuracy is approached (I said approached, not achieved), amplifier-type test procedures will have to be used. I don't think we're there yet; the differences are still not all that subtle; but I am beginning to do some preliminary explorations of speaker ABX-ing. (See also my comments on this subject in Issue No. 20, p. 39).

Note to new readers.

Background information on how we measure and evaluate loudspeakers, why we do it that way, what we don't do and why not, what we wish we could do, etc., is scattered throughout Issues No. 10, 11, 14, 16, 17, 19, and 20. There is no way to rehash all that material here for new readers; all those issues are still available, however, except No. 10.

B&W Matrix 803 Series 2

B&W Loudspeakers of America, P.O. Box 8, North Reading, MA 01864-0008. Voice: (508) 664-2870. Fax: (508) 664-4109. Matrix 803 Series 2 floor-standing 3-way loudspeaker system, \$3000.00 the pair. Tested samples on loan from distributor.

This is not the flagship of the B&W line but it represents the most recent and therefore probably the most mature implementation of their technology and design philosophy. It is a very well-designed, very accurate, one could say almost flawless, monitor-type loudspeaker. If my listening room were smaller, and if the fixed tweeter

level were set just a smidgen lower (maybe by only 1 or 2 dB), the 803 Series 2 would probably be a contender for reference status in my ranking of speakers, at least as a one-piece system of reasonable size—it's that good. As it is, however, it sounds somewhat unassertive in size and dynamics in the big room where I do most of my listening and also a wee bit zingy on top. It sounds closer to what I consider just right in a smaller room where I also tried it.

The speaker is 40" high, 10" wide, and 13" deep (in round numbers). The 1" metal-dome tweeter sits on top of the cabinet in a separate streamlined pod, in the manner of all B&W 800 Series models. Three 6½" drivers are mounted in a vertical line on the front side of the cabinet. The topmost one is a Kevlar-cone bass/midrange driver, the other two are Cobex-cone bass drivers. The vented enclosure has its ducted port below the bottom driver. The vertical edges of the cabinet are beveled, and the grille is of a vaguely nondiffractive design (not as clever as that of the Thiel grilles but of smaller importance here because of the free-standing tweeter).

The bass system of the 803 Series 2 uses a vented box with 4th-order Bessel alignment—more or less—plus an optional filter that can be connected between preamp and power amp, or alternately switched in out of a tape loop, in case you prefer a 6th-order Butterworth alignment. I was perfectly happy with the "Besselish," filterless alignment, which produced a nearfield response curve that sloped gently downward from approximately 80 Hz to 20 Hz at an average rate of 2 dB per octave and then broke sharply below 18 Hz at 12 dB per octave—an overdamped profile. (I must add, however, that I always have some minor reservations about the accuracy of a bass response curve such as this, taken at the best apparent nearfield summing junction of the woofer and the vent.) The box was tuned to 20 to 22 Hz; the maximum output of the vent was at 19 Hz. The speaker put out a remarkable amount of tightly controlled, deep, accurate bass for such a relatively slender, compact unit. The filter, which B&W did not send me, would have flattened the response in such a way that there would have been a stonewall cutoff at 23 Hz and dead level output above that, with much looser damping.

One widely advertised feature of all B&W 800 Series loudspeakers is their unique cabinet construction, indicated by the Matrix designation before the model number. The Matrix technique uses an elaborate honeycomb of internal braces to reduce cabinet resonances—there is almost as much bracing as there is air inside the cabinet. Here, in the 803 Series 2, the "next-generation" Matrix 2 construction is introduced, with even more sophisticated bracing of the upper (mid/bass) subenclosure. When I tapped the center of the cabinet's side panel with the little padded hammer I use for that purpose, it didn't sound as dead as I had hoped; it appeared to be slightly more pitched (tonal) in response to the tapping than some

cabinets without such high-tech credentials. I heard no corresponding coloration, however, in the output of the speaker.

The quasi-anechoic (MLS) frequency response of the speaker from 300 Hz up proved to be extremely flat. With the microphone on the axis of the mid/bass cone, the response is within ± 2 dB up to 20 kHz; furthermore, the 300 Hz to 6 kHz segment is within ± 1.25 dB, and the 6 kHz to 20 kHz segment is within ± 0.75 dB. The overall trend is ever so slightly upward, confirmed by the axial response of the tweeter. The flattest response was obtained 30° off axis horizontally, with the microphone aimed at the apex of the mid/bass cone: ± 1.5 dB from 300 Hz to 16 kHz, down by 3 dB at 20 kHz. Maybe if the tweeter were set a dB or two lower, as I suggested above, the latter measurement would be unobtainable, but I think I would still prefer the sound that way. Remarkable results, in any event. (Incidentally, the phase curve was also unproblematic, with only about 180° of rotation over the measured range.)

In the time domain, tone bursts elicited no discernible ringing at any frequency—again remarkable. The impedance curve, on the other hand, is a roller coaster, fluctuating between 3.3 and 24 ohms (the latter at 1.5 kHz!) in magnitude and $\pm 50^\circ$ in phase. Not exactly an R-like load for the amplifier. (You can use two amplifiers, however, as there are terminals provided for biamping via the passive crossover or, needless to say, for tweako biwiring, which is strongly recommended in the manual—but who knows what marketing type wrote that.) The nominal impedance of the speaker is given as 8 ohms, which is the value at 400 Hz, as well as at 4 kHz. I did not make extensive distortion measurements, only enough to determine that the distortion is reasonably, but not exceptionally, low. Efficiency is quite high but hard to nail down because of the difficulty of measuring power into that roller-coaster impedance.

In a medium-sized room the sound of the B&W Matrix 803 Series 2 is that of a highly accurate forward-firing monitor and pretty much above criticism within that genre. I have no reservations about it other than what I have already noted. The speaker simply reproduces its input without significant alterations and launches it forward into the room. If that's what you want, this is one of the very few designs you need to check out. My plan is to live with it a little longer, possibly do a followup report with additional measurements, and use it as a convenient norm in monitor-type speaker evaluations, since the B&W 800 Series is widely recognized as a reference.

NHT Model 3.3

Now Hear This, Inc., 535 Getty Court, #A, Benicia, CA 94510. Voice: (707) 747-0151. Fax: (707) 747-0169. Customer service: (800) NHT-9993. Model 3.3 floor-standing 4-way loud-

THE AUDIO CRITIC

speaker system, \$4000.00 the pair. Tested samples on loan from manufacturer.

If you have read the interview with NHT's Ken Kantor in our last issue, or have been exposed elsewhere to his ideas, you already know that he is a formidable and highly original thinker on the subject of sound reproduction. This new loudspeaker system, his most ambitious design to date, confirms and documents that perception. In my experience as a reviewer, the NHT Model 3.3 is the most unconventional implementation of basically conventional transducer/enclosure technology and probably the most nearly perfect. That doesn't necessarily make it irresistible to me as a music lover, but it is certainly a world-class design by any criterion.

The unconventionality of the speaker is immediately apparent from its shape and driver deployment, both of which are ingeniously conceived to *compel* correct room placement—the user actually has no other practical choice. The enclosure is a big, flat slab, 42" high by 31" deep by only 7" wide, which must be placed with the narrow front side facing the listening area and the opposite narrow side against the back wall. (If you don't have an available back wall, the speaker is not for you, at least in my opinion.) The left and right units are mirror-imaged, each with a 12" woofer mounted inboard in the "corner" formed by the side of the slab and the wall. That provides four times the radiation resistance of conventional floor placement out in the room, with vastly increased drive capability at the bottom frequencies. The narrow front face of the slab is angled inboard (i.e., with built-in toe-in) and has three more drivers mounted on it, each in its own subenclosure: a 6½" upper-bass/lower-midrange unit, a 4" upper-midrange unit, and a 1" dome tweeter. (See also the front cover of this issue.) Thus the woofer is where it should be, in a corner, and the midrange/treble part of the speaker is also where it should be, out in the room like a typical audiophile minimonitor. Clever, these Americans....

I developed a particular admiration for the woofer design, which uses only 70 liters (2½ cubic feet) of sealed space behind the 12" sideways-firing polymer-cone driver. The skinny cabinet allows no larger volume; nevertheless, the bass is the finest I have ever heard out of an unequalized and passively crossed-over sealed box of less than giant size. It remains tightly controlled and natural-sounding on the biggest bass-drum whacks and most powerful organ pedal blasts. Ken Kantor credits NHT's Bill Bush (an amateur bassist!) for the driver design; the actual OEM for the 12" unit (as well as the 6½" one) is Tonegen, a Japanese firm. My nearfield measurement of the woofer showed the characteristic 12-dB-per-octave bottom-end rolloff of a sealed box; the -3 dB inflection was at 35 Hz; there is a tiny notch at 23 Hz, which is probably the limit of useful response. The virtual corner boosts the in-room response at the bottom end

ISSUE NO. 21 • SPRING 1994

considerably, of course. The fundamental resonance of the sealed box appears to be 29 Hz from the impedance curves, suggesting a very slightly overdamped condition, which is desirable in this type of design.

The other three drivers are configured in accordance with NHT's so-called Focused Image Geometry. That means the front baffle is angled inboard by 21°, which in the Ken Kantor canon is the optimum angle for minimizing interaural cross-correlation—as long as the listener is equidistant from the two speakers—and thereby optimizing stereo separation and ambience retrieval. (More about that below; see also the aforementioned interview in Issue No. 20.) A strip of absorptive foam on the outboard side of the midrange and tweeter units helps to direct the sound radiation toward the listening area and away from adjacent walls. The whole thrust of NHT's approach is to bring the stereo information to a focus in the listening area and minimize the effects of room acoustics on the quality of the reproduced signal.

The drivers in the Model 3.3 are crossed over as follows: 12" to 6½" at 100 Hz, 2nd-order slopes; 6½" to 4" at 320 Hz, 2nd-order slopes; 4" to 1" at 3.5 kHz, 3rd-order slopes. A positive-going pulse at the input of the system causes a forward excursion of the 12" and 6½" drivers and a rearward excursion of the 4" and 1" drivers. This is as it should be with the crossover orders used, except for the 100 Hz crossover, where out-of-phase wiring would be expected with the 2nd-order filters; the large distance between the drivers probably accounts for the decision to do otherwise.

The frequency response of the speaker is amazingly flat; indeed, the on-axis response of the tweeter (a 25-mm aluminum-dome unit with magnetic fluid damping, made by SEAS of Norway) is almost amplifier-flat—and I mean ±0.5 dB—from about 8.5 kHz to 22 kHz. Way up in the ultrasonic 25 kHz region the tweeter has a resonant peak; below 8.5 kHz there is a tiny downward step; but even so the 1-meter quasi-anechoic (MLS) response of the total system on axis is flat within ±1.5 dB from 22 kHz on down to the woofer range—which is really something and shows that the 4" SEAS upper-midrange unit is no slouch, either, over its 3½-octave band. Off axis in the horizontal plane one has to distinguish inboard vs. outboard response, the latter being deliberately barricaded by the foam strip. Inboard there is very little off-axis rolloff even at the highest frequencies, but remember that "on axis" in this speaker means 21° inboard to begin with, so that off-axis measurements beyond an additional 20° are hardly meaningful. In the vertical plane the off-axis measurements show mainly a tendency toward a suckout around the 3.5 kHz crossover point—not a major fault in my opinion. The phase response of the system is unproblematic and, given this particular configuration, basically what I would expect. Overall, I haven't seen a better passive 4-way solution by any other designer, or even one as good.

The Model 3.3 also excels in THD + N. It is very difficult to make it distort more than 1% at any frequency above 50 Hz without pushing the output to nearly unbearable levels, and that figure drops sharply as the drive is reduced. At the lowest frequencies (20 to 40 Hz) all bets are off at high SPLs, as is usually the case, but the higher-order harmonics are still very low.

I must add that none of my measurements differed significantly from the manufacturer's specs and curves, which appear to be remarkably honest. I wish I could say the same of all loudspeaker brands. One thing that NHT does not talk about but I found to be outstanding is the complete freedom from ringing on tone bursts, regardless of frequency. The reproduction of gated square pulses is far from coherent; the waveforms emerge somewhat disorganized, but less so than with other 4-way speaker systems known to me. Let us not forget about the impedance curve: above the woofer range it varies only from 4.5 ohms to 7.5 ohms in magnitude (6 ohms nominal); at the 29 Hz box resonance it rises to 10.5 ohms (only!); the phase is well within $\pm 30^\circ$ at all frequencies. A piece of cake for any amplifier—or two amplifiers, as there are terminals provided for biamplication via the passive crossover. (Or biwiring if that harmless delusion makes you feel better.)

The only thing I found objectionable about the Model 3.3 had to do with the stabilizer bars which must be screwed to the bottom to keep the heavy (123 lb.) but wafer-thin cabinet from toppling over sideways. For \$4000 one has the right to expect high-quality machine screws and threaded inserts for attaching the stabilizers; instead I had to screw huge self-tapping wood screws into hardwood and was rewarded with blistered palms for my unskilled effort. I never affixed the pointy cones the stabilizer bars are supposed to rest on; they are not for the reviewer who constantly moves things around on the floor.

Well, you probably thought I'd never get around to the subjective listening quality, but here goes: Very accurate, transparent, and neutral—like the best of Snell, but even more so. Not very forgiving when the recording is overbright. Perfectly balanced when the recording is. A little more open and airy than the Waveform Mach 7 but maybe not quite as dynamic. Medium-sized wave launch into a large listening room—I wish it presented a larger apparent source, but it certainly doesn't sound small. Beautifully delineated, strong bass, as discussed above, though not quite on a par with the most sophisticated sub woofers.

As for the Focused Image Geometry, I am the wrong person to ask. Amazing snap-into-focus 3-D imaging is not my Holy Grail because I do not hear it in the concert hall; it seems to be achievable only with microphones. I am basically a tonality/balance/transparency man. Ken Kantor wants the new owner of a Model 3.3 to set it up with half-inch-by-half-inch trial-and-error

changes in position, separation, parallelism, etc., until the focus snaps in like a seat-belt buckle. I have no patience for that. After attaching the stabilizer bars I placed the speakers perpendicularly against the back wall a little over 8 feet apart, and they imaged/soundstaged just fine without further ado. There are other speakers that will not image one tenth as well, no matter what you do.

Bottom line: the NHT Model 3.3 is a marvelous speaker and perhaps not even overpriced at \$4000, but for me it doesn't have that ultimate I-can't-live-without-it quality because, ideally, I want a bigger apparent sound source plus dead-flat low-frequency response down to the subsonic region. Ken Kantor claims that this is best loudspeaker system he knows how to make, regardless of price, but I don't for a moment believe that. It is probably the best 3½-foot-high monolithic 9½-octave-range speaker he knows how to make. Or anyone else knows how to make, for that matter.

Sequerra Model NFM-PRO

R. Sequerra Associates, Ltd., 792 Pacific Street, Stamford, CT 06904. Voice: (203) 325-1791. Fax: (203) 325-0263. Model NFM-PRO 2-way nearfield-monitor loudspeaker system, \$2000.00 the pair. Tested samples on loan from manufacturer.

Dick Sequerra clearly has nine lives as an audio entrepreneur; this particular engineering/marketing effort represents the sixth one I am aware of but I may have overlooked one or two. Right now the NFM-PRO constitutes the sum total of his active product line, or close to it, as I understand from my brief conversations with him.

This is a teeny-weeny speaker, 11" high and deep, 6¾" wide, with 10 of its 12 edges rounded, no grille, black Nextel finish all around. The driver complement consists of a 6" plastic-cone woofer and, believe it or not, a 2¼" paper-cone tweeter with an aftermarket phasing plug. Dick Sequerra hates dome tweeters and is the only one in the hi-fi loudspeaker industry (to my knowledge) to use this Japanese-made cone tweeter. His main reason, I believe, is power handling. The crossover appears to be first-order (Dick Sequerra also hates 4th-order Linkwitz-Riley, etc.), and the woofer protrudes 1¾" from the box by means of a short tube extension in pursuit of better time alignment. The tweeter level can be adjusted up and down over a narrow range with a 6-position rotary switch in the back.

How can such a simple little speaker cost \$1000 per side? For one thing, it is very solidly built and, in its austere way, carefully finished. For another, it is made primarily for the professional market, to sit on top of a console for nearfield monitoring, and that market isn't necessarily driven by apparent-hardware-value-per-dollar. Furthermore, Dick's prices have always been somewhat arbitrary, based on—shall we say?—audiophile-awe-per-dollar. The NFM-PRO is, in effect, a slicker and more

THE AUDIO CRITIC

highly refined version of the Sequerra Met 7 series of minimonitors. I have no idea how many of the paper-cone tweeters, for example, Dick must test, select, and reject before he picks one for this speaker, so I can't really comment on the fairness of the price. Cheap it ain't.

My nearfield measurement of the woofer in its sealed enclosure showed a typical "maximally flat" 2nd-order response profile, with the -3 dB point at 70 Hz and a 12 dB per octave decline below that frequency. I can't see anyone getting more bass out of that small box. Nor can I see anyone using the speaker without a subwoofer in a home music system. (A studio engineer who already knows the bass response of the monitored loop is a different story.)

The 1-meter quasi-anechoic (MLS) frequency response of the NFM-PRO is reasonably flat on axis—with the tweeter level control in the 0 position—but falls apart dramatically off axis. The axial response is flattest with the microphone aimed slightly above the apex of the woofer: ± 3 dB from 300 Hz to 17 kHz. Even within that tolerance the cone tweeter shows more roughness, more small resonances, than typical dome tweeters. The phase curve stays within a much narrower angular range than that of more complex speakers. At 30° off axis horizontally, a huge suckout (-13 dB) occurs at 2.3 kHz and the tweeter response remains flat only up to 6 kHz, dropping to -6 dB at 9 kHz and showing no response at all above 14 kHz. Welcome to the world of first-order crossovers and big cone tweeters. Vertically off axis the picture is quite similar. The speaker *must* be placed at ear level and toed in, and that of course is the usual position on top of the studio console. (Think of a pair of huge headphones and you'll know how to use the NFM-PRO.) I must admit, though, that the speaker is efficient and will play very loud. The 1-watt 1-meter SPL is at least 90 dB and may be as high as 93 dB—I obtained different figures with different methods of measurement. The impedance curve is very nice, between 6.3 and 10.5 ohms in magnitude at all frequencies above the box range (i.e., 8 ohms nominal), the phase remaining quite close to the 0° axis throughout.

In the time domain, where the speaker is claimed to excel, I observed good, but not amazing, reproduction of gated square pulses. For amazing pulse-shape retention you need great bandwidth, which is not the case here. The leading edges looked nice, however, thanks to the driver alignment and first-order network. The trouble is that I no longer believe in coherence, per se, as an audible benefit. Ringing, on the other hand, is unquestionably audible, and the NFM-PRO reproduces tone bursts of all frequencies quite cleanly, with only a small amount of ringing here and there, nothing to fault seriously.

The sound of the speaker corresponds quite closely to what one would predict from the measurements. Light bass, no highs off axis, a bit of roughness on axis, very good dynamics, no surprises. Imaging is good, as it is

with nearly all tiny loudspeakers. Everything considered, in a world of good, bad, and mediocre speaker systems, this one falls into the good category. I could live with it (plus a subwoofer) if nothing else were available. But I recall the Fried Q/4 at \$498 the pair—returned long ago—as being smoother and more transparent; David Rich's Monitor Audio Studio 6's (\$2499 the pair) proved to be far superior on all counts in a side-by-side comparison; and the new Velodyne DF-661 at \$1695 the pair (in black vinyl) is in an altogether different league—but read the preview below. By top-of-the-console near-your-head criteria, on the other hand (i.e., very small, very loud, reasonably accurate), I would say the Sequerra Model NFM-PRO delivers what it promises.

Velodyne DF-661 (quick preview)

Velodyne Acoustics, Inc., 1070 Commercial Street, Suite 101, San Jose, CA 95112. Voice: (408) 436-7270. Fax: (408) 436-7276. DF-661 "Distortion-Free Full-Range Loudspeaker," \$1695.00 the pair in black vinyl, \$2245.00 the pair in rosewood. Tested samples on loan from manufacturer.

We were late, ridiculously late, and then this came in. If we hadn't been late, I couldn't have inserted this preview here, so every cloud has a silver lining—if you'll pardon the cliché—because this speaker appears to be a major development and you should be aware of it. Please understand, however, that this not an actual test report; that will be presented in the next issue, after sufficient exposure to the speaker in the laboratory and the listening room

The DF-661 is a bookshelf-sized 3-way speaker system with a 6" metal-cone woofer in a vented enclosure, 6" metal-cone midrange driver, and 1" metal-dome tweeter. The two 6" units are of a totally new and different design, claimed to reduce distortion by a whole order of magnitude (i.e., divide the distortion by 10) in comparison with other good loudspeakers. That means distortion on the scale of amplifiers rather than electroacoustic transducers! Other than that, no special claims are made for the DF-661—no claims regarding frequency response, diffraction, coherence, cabinet construction, etc.

I have run only a very few quick-and-dirty tests on the speaker, just to still my curiosity, and am far from ready to discuss numbers here. I have listened to the unit at some length, however, and I can report that the claims for it appear to be true. Ultralow distortion in a speaker does sound different, quite different indeed, and can easily become addictive after several days of listening. My initial impression is that as a *system* design the DF-661 could stand some improvement, but the *texture* of sound that emerges from it—as distinct from structure and balance—sets a new standard.

More than that I will not say at this point. To the

orthopedic surgeon with a couple of G's burning a hole in his pocket my message is this: (1) my heart bleeds for you, doctor, because your new toy, should you decide to go ahead and buy it now, does not yet have my official blessing, and that's that; (2) what the hell, doctor, throw caution to the wind and get the DF-661 without waiting for Issue No. 22—the risk is small.

...and, by contrast, a dipole:

Magneplanar MG-1.5/QR

Magneplanar Incorporated, 1645 Ninth Street, White Bear Lake, MN 55110. Voice: (612) 426-1645. Fax: (612) 426-0441. Magneplanar MG-1.5/QR 2-way quasi-ribbon/planar-magnetic loudspeaker system, \$1350.00 the pair. Tested samples on loan from manufacturer.

Yes, I have a soft spot for planar/dipole/line-source speakers, mainly because of their "room-friendly" wave-launch characteristics; but no, I never had a big love affair with Magneplanar's products, even though they have been very influential in the market and have a number of strong virtues to recommend them. My two main problems with them have always been, as far back as the late '70s, bass performance and ringing diaphragms. That doesn't seem to have changed much to this day.

It is Magneplanar's party line that Magneplanar bass (remember, Magneplanar is the company and Magneplanar the brand) possesses *quality*, whereas the bass you get with subwoofers and their ilk is characterized by mere *quantity*. Well, this reminds me of locker-room arguments about the mammary endowment of cheerleaders; the fact is, however, that a peripherally clamped plastic sheet, even if driven over its entire surface as in the Magneplanars, is not really a quality solution for bass reproduction. A properly suspended and terminated stiff cone driven at its apex and enclosed in a correctly designed box is a much better-controlled and predictable low-frequency transducer, though perhaps lacking in high-tech glitz by comparison. As for ringing... but I'm getting ahead of myself.

The Magneplanar MG-1.5/QR represents the top of Magneplanar's "cheaper" line, i.e., the line without genuine ribbon tweeters. The tweeters in this not-quite-high-end line are called "quasi-ribbon" by the manufacturer; less scrupulous companies would call them ribbon, period, which they aren't. In effect, these quasi-ribbon tweeters are based on the same flat-Mylar-diaphragm-with-distributed-voice-coil principle as the low-frequency transducers in the speakers. I have discussed this approach to transducer design a number of times in the past and do not intend to go over the same ground again (see,

for example, Issue No. 11). Magneplanar's literature clearly explains the design principle, but naturally only the pros without the cons. Suffice it that the MG-1.5/QR is a 64" high, 19" wide panel divided into a large low-frequency section and a tall, narrow (i.e., ribbon-like) high-frequency section. The left and right units are mirror-imaged. The electrical crossover frequency appears to be 700 Hz, although the specs say the acoustical crossover is at 1 kHz. The lowpass filter is 2nd-order; the highpass filter is 1st-order (series capacitor).

The measured impedance curve indicates that the low-frequency and high-frequency transducers are both essentially resistive (5.2 and 3.7 ohms respectively) but that the crossover network synthesizes a fairly complex load: magnitude, 3.7 to 29 ohms (peak at the crossover); phase, -55° to $+40^\circ$. The nominal impedance is 4 ohms. Terminals are provided for biwiring (pure nonsense) or biamping via the passive crossover (marginally advantageous). The low-frequency and high-frequency sections are wired out of phase (probably because the overall acoustical profile of the crossover is closer to 2nd-order than anything else).

When the sound source is a tall structure like the MG-1.5/QR, its frequency response is not as easily measurable as that of a minimonitor or even a fair-sized box speaker. I opted for 2-meter MLS (i.e., quasi-anechoic) measurements with the microphone aimed at the high-frequency strip from various heights and at various horizontal angles. I also took nearfield measurements of the low-frequency panel. I would have preferred outdoor measurements from a distance of 3 or 4 meters, but that was not an available option. I am reasonably certain, however, that I have a good handle on the speaker's overall response characteristic, even if the accuracy isn't the highest possible.

The bass response of a speaker like the MG-1.5/QR is hard to quantify with my usual nearfield technique because the real-world bass output of a dipole exists only at some distance from the launch point on account of the back-to-front cancellation. I was able to determine that the fundamental resonance of the "drumhead" (because that's what the low-frequency panel really is) was at 44 Hz, with steeply falling output below that frequency, and that there was another big bump at 75 Hz, the really smooth response starting only at 125 Hz and continuing (now on the basis of MLS) up to 1.3 kHz or so. Those three-plus octaves look very nice and are probably the long suit of the speaker. From there on up things get rough again; the response up to 20 kHz is a series of peaks and dips. The biggest dips are -7 dB on axis and -10 dB off axis (30° inboard); the biggest peaks are smaller, maybe +5 dB; the whole response profile is much more ragged than anything we have seen in quality speakers of conventional design. The high-frequency response above 11 kHz declines 6 dB per octave off axis. Even allowing for some measurement errors, this is not

THE AUDIO CRITIC

an altogether happy picture.

In the time domain the picture is no happier. A tone burst consisting of 10 cycles of 500 Hz makes the low-frequency panel produce 10 more cycles only about 14 dB down from the input. The same panel, when excited with a single cycle of 20 Hz, produces another cycle at the original level and then a decaying series of six more cycles starting at only 9 dB down. That panel is alive! The high-frequency strip also rings badly: a 4 kHz tone burst of 10 cycles makes it produce 16 more decaying cycles, starting at 6 dB down and persisting at 12 dB down most of the way. As for coherence, I found a 1 kHz square wave to be pretty badly mangled by the crossover, but a 2 kHz square wave came off the high-frequency strip looking quite nice.

How does all that affect the speaker in terms of subjectively perceived sound? More or less as you would expect: not enough bass, not enough highs (at least from some listening angles), not enough focus, too much coloration, an overall not-quite-neutral quality. Lest that should appear like a totally negative reaction to the speaker, I must add that I still liked the planar wave launch—the height and width of the apparent sound source were just right, and that made for reasonably happy listening despite all of the above. Even a faulty planar speaker has a certain dimensional Tightness about its sound.

Since I had not looked at a Magneplanar product for years, I felt a little uneasy about the possibility that this single unenthusiastic review would define my view of *all* Magneplanars in the eyes of our readers. I therefore borrowed a pair of **Magneplanar Tympani IVa's** from a friend and put it through its paces. The Tympani IVa, with three screenlike hinged panels per side and a bona fide ribbon tweeter, was until 1992 the top of the Magneplanar line at \$3750.00 the pair. It is no longer made, having been replaced by the single-panel MG-3.3/R (\$3000.00 the pair) and single-panel MG-20/R (\$8500.00 the pair). All I wanted, however, was a generic high-end Magneplanar for reference and comparison, and the IVa served that purpose very well. It is an incomparably better speaker than the MG-1.5/QR (at almost three times the price it had better be!) but it still has some of the same generic shortcomings. It rings all over the place in much the same manner (not the ribbon, though), and the bass is still far from superb, with a big bump at 35 Hz and poor damping. A single Velodyne ULD-15 Series II made the whole system sound significantly more authoritative below 85 Hz. The frequency response of the IVa, however, is much flatter and less ragged than that of the MG-1.5/QR, and in the 2½ octaves from 100 to 600 Hz (upper bass and lower midrange) the IVa is extremely impressive, with tremendous impact and dynamics resulting from the huge drive area. No conventional speaker I know of is its equal in that respect. On the other hand, imaging and directional cues are quite vague on the IVa, ISSUE NO. 21 • SPRING 1994

and the overall sound has a subtly colored, zingy character. The apparent sound source is of course huge. Not a negligible speaker, all in all. (Now it's history, in any event.)

I am hoping that the Magneplanar MG-20/R has the answers to all (or at least most) of the questions raised by the intrinsically problematic nature of this kind of planar-magnetic design and that Magneplanar will not punish us for our detached objectivity (read lack of groupie adulation) by denying us test samples.

..plus, a very different subwoofer:

Bag End ELF Systems S10E-C and S18E-C

Modular Sound Systems, Inc., P.O. Box 488, Barrington, IL 60011. Voice: (708) 382-4550. Fax: (708) 382-4551. ELF-1 two-channel dual integrator electronics, \$2460.00. S10E-C black-carpet enclosure with single 10" woofer, \$234.00 each. S18E-C black-carpet enclosure with single 18" woofer, \$658.00 each. Tested samples on loan from manufacturer.

I was tempted to call this a preview because I am still in the process of evaluating the ELF approach to bass reproduction and far from finished, but then a preview is supposed to be much more tentative in its conclusions, if any, than mine already are about this remarkable product. The truth is that I was just about finished with speakers for this issue when the ELF system arrived, and I wasn't going to get involved in it before press time. Well, I did get involved in it and got hooked. So here goes this first-look, more-than-just-a-preview early review:

I have never heard bass like this in my listening room. I didn't even know what I was missing. How's that for openers?

Now, in all fairness I must hasten to point out that I never had in my system a pair of those floor-to-ceiling multiple-woofer towers (as in the Infinity IRS, Martin-Logan Statement, Genesis I, etc.), nor a pair of Velodynes (only a single matrixed ULD-15 Series II), nor any number of other highly regarded sub woofers. I have heard these elsewhere but not in my familiar environment. To my ears none of them had the Bag End ELF sound—but that, of course, is the kind of anecdotal report you should never trust.

Bag End is the cutesy brand name chosen by Modular Sound Systems, a Chicago firm, for their line of speakers. (The name comes, I believe, from J. R. R. Tolkien's *The Hobbit*.) Although virtually unknown in the high-end audio community, Bag End is a familiar brand in the field of professional sound (music stores,

rock groups, sound system specialists, etc.). What's good for road shows, arenas, and churches isn't automatically bad for high-end home music systems, as some snobby tweaks will immediately think. *Au contraire*, the ELF system was developed by heavy-duty technologists in search of the most accurate bass, not by ex-salesmen who learned their physics on the floor of an audio store and talk about "fast" woofers. Our readers have probably heard of one of the designers, Ed Long, who writes an occasional technical review for *Audio* and owns various audio patents. Ron Wickersham was the other half of the ELF development team. Long and Wickersham are not part of Modular Sound Systems, which is a licensee and is run by Jim Wischmeyer and Henry Heine. ELF is a cutesy acronym for Extended Low Frequencies—and that means extended down to 8 Hz. Really. I measured it, hobbits and elves notwithstanding.

The basic idea behind the ELF approach is one of those hey-I-thought-everybody-knew-that insights, really simple and obvious once it is stated. What is the main problem to be solved by the designer of a superior speaker system for bass reproduction? Answer: pushing the fundamental resonance as far down as possible and controlling it down there. The ELF solution to the problem: let's not solve it! That's always an excellent solution when there exists a viable alternative, which in this case is pushing the fundamental resonance as far *up* as possible, let us say to 70 Hz. In a sealed box, the response below that frequency will decline by 12 dB per octave, predictably, linearly, unproblematically, without resonances. All you have to do is to boost the drive signal by 12 dB per octave below 70 Hz and you can have flat, resonance-free, perfectly controlled bass down to practically dc. Of course, such a drastic boost takes a lot of amplifier power, not to mention an extremely linear high-excursion woofer, but watts are relatively cheap and a good driver is needed with just about any design approach. All this is a somewhat simplistic abstract of the ELF concept, but I want all readers to grasp at once its simple and plausible essence. (I do not guarantee, of course, that the idea had never occurred to anyone before Long/Wickersham implemented it. One could even argue that Roy Allison's Electronic Subwoofer from the late '70s bears some resemblance to it, although Allison did not try to push the resonance as high up as possible.)

There are other advantages that come automatically with a higher fundamental resonance. The woofer cone can be lighter. That means higher efficiency. The enclosure can be smaller. The Bag End S10E-C and S18E-C systems aren't very much bigger overall than the carton in which the 10" driver and, respectively, the 18" driver came. One of the nontrivial design challenges posed by the ELF concept is what circuitry to use before the power amplifier input to boost the signal 12 dB per octave down to 8 Hz (i.e., close enough to dc but still safely above it for real-world amplifiers and woofers). There will be an

explanation in the next issue of the circuit details of the unorthodox ELF solution, which is incorporated in the \$2460 ELF-1 electronic unit and which we haven't tested yet as a separate component. The heart of the circuit is described as a *dual* integrator (with the emphasis on "dual"). This is rather different from the conventional lowpass-filter type of bass equalizer and is claimed to have many advantages. Very briefly, the main advantage, in addition to inherently excellent linearity down to virtually dc, is that the very low permissible low-frequency cutoff (almost dc-ish at 8 Hz) results in significantly improved signal-delay characteristics in comparison with conventional bass-response profiles. Time offset, which in the case of low-frequency transducers is of more than just tweako concern, thus becomes a relatively innocuous issue with the ELF system.

The basic ELF electronics could be implemented much more simply and cheaply than in the ELF-1, which is an incredibly elaborate and versatile professional unit with balanced inputs/outputs (only!) and a zillion possible settings and adjustments. Its so-called concealment circuit is a particularly sophisticated adjustable control feature which is actually essential with the 8 Hz cutoff to protect the typical amplifier from overload. The ELF-1 also provides electronic crossover and level setting facilities for the main amplifier/loudspeaker system. Details about all that will be part of the more technical followup review in the next issue; meanwhile I should note that Modular Sound Systems is definitely interested in the home audio market and new, more audiophile-oriented versions of the Bag End ELF products can be expected. The earliest sign of that is a substitute front panel for the ELF-1 with a much more High End kind of look than the very utilitarian decal-labeled original. As for the woofer enclosures, I absolutely love the indestructible carpet-covered road-show versions they sent me, complete with corner protectors and handles, but for the home market they will have to make the entire line available in various veneers, not just the one 18" model in oak veneer as at present.

A single ELF-1 control unit can drive any number of amplifier/subwoofer hookups, as long as it sees at least 600 ohms. One of the beauties of the system is that the different subwoofer models, regardless of size, all have essentially the same response characteristics, differing only in efficiency and maximum SPL capability. Thus multiple arrays can be used to increase subbass output and reduce distortion ad libitum. I am not quite finished yet with my measurements of the distortion characteristics of a single S10E-C and single S18E-C; the complexity of the electronic signal path makes the process a bit more than routine; I can confidently predict, however, that the final results will be somewhere between very good and excellent.

To get back to the subjectively perceived sound of the Bag End ELF system, I find it more solid, clearer,

THE AUDIO CRITIC

more detailed, less nimbly, more revealing than that of any other subwoofer known to me. It would seem that getting rid of a very low fundamental resonance as the crutch for low-frequency extension also gets rid of a certain vagueness of definition in that range. That of course is speculation without proof. If you want objectively verifiable and repeatable observations, I have only gone as far as to measure the nearfield frequency response. That goes down flat well below the lowest audible tones, as I said, with worst-case deviations of less than 1 dB. And that goes for both models. So much for now—to be continued.

(Just before press time, a pair of Velodyne Servo F-1500R's arrived. That will be *some* shootout!)

...lastly, an acoustical accessory:

MSB Acoustic Screens

MSB Technology Corporation, P.O. Box 141, Moss Beach, CA 94038. Voice: (415) 728-5265. Fax: (415) 747-0405. MSB Screen, 6 ft. high with three 2 ft. wide folding sections, \$400.00 (\$800.00 the pair). Tested samples on loan from manufacturer.

I got into trouble with MSB Technology by being disrespectful to their "EMA Isolation Plate" in an editorial reply to a subscriber's letter in Issue No. 18. They wrote a long letter, published and answered (with "case-closed" finality, in my opinion) in Issue No. 19; they complained to us verbally as well; however, as of the

time this is being written, I still have no test data from them proving that they are right and I am wrong, only promises that such proof is coming. I shall now redeem myself (in their eyes, I hope—in mine I need no secular redemption) by warmly recommending their acoustic screen product.

What we have here is a handsome and useful piece of furniture, a three-section folding screen covered with the same acoustical fabric on both sides. Two short, rounded maple legs support the frame of each section and keep it off the floor. The hinges work in either direction, and the screen is self-supporting in just about any folded or unfolded position except a straight line. Under the acoustical cloth are three separate layers of special damping material. I do not have an established test protocol for quantifying sound absorption—one of these days, maybe—but I can tell you that the device works.

Two of these screens can make a serious difference in stereo loudspeaker deployment. Putting a screen behind each speaker system in a shallow U shape will block just about all backwall and nearby sidewall reflections, yielding a strictly forward-firing launch. That can eliminate a lot of soundstaging confusion in certain setups. You can also cover reflective surfaces anywhere else in the room for improved acoustics. The screens can be moved easily by one person and folded when not in use.

It would be an exaggeration to report that the MSB Acoustic Screens changed my audio life, but I will say that after you have used them for a few weeks you don't want to be without them. They are a bit pricey, though, for something that couldn't cost all that much to make. •

Jitter (continued from page 22)

of the jitter spectrum and the type of converter used. One-bit noise-shaping converters with no discrete-time output filter are an order of magnitude more sensitive to white phase jitter on the clock than either resistive ladder DACs or 1-bit converters that use switched-capacitor output filters. Continuous-time filtering of 1-bit outputs does not reduce jitter sensitivity.

The use of oversampling filters in conjunction with standard multibit or 1-bit DACs with switched-cap filters reduces jitter sensitivity in proportion to the oversampling ratio, assuming white phase jitter. The effect of low-frequency correlated phase jitter is not significantly reduced by oversampling.

A new, properly designed asynchronous sample-rate converter allows jitter on either the input or the output clock to be heavily filtered, ISSUE NO. 21 • SPRING 1994

thereby dramatically reducing errors caused by jitter. This filtering is accomplished by computing an internal estimate of the sample-rate ratio over many thousands of clock cycles, so that individual jittered clock edges are prevented from affecting the computation.

The use of this new IC in outboard D/A conversion applications allows the designer to use a fixed crystal clock circuit for the converter, while accepting a jittery input clock (most often recovered from an incoming AES/EBU or S/PDIF serial stream).

It is recommended that jitter measurement of internal clock signals be used by equipment designers as an aid to achieving good signal quality, but that reviewers should not attempt to assess signal quality based on jitter measurements, since the

amount of signal degradation caused by jitter is a complex combination of many design factors. It is better to measure the analog output signal itself, as this is what is ultimately reproduced. Most conventional THD + N and spectrum analyzer tests will adequately expose any jitter-related problems, especially those that subject the D/A system to high-amplitude high-frequency signals. A noise-modulation test may be added to look for the effects of broadband phase jitter.

8 References

Adams, R. W. and T. Kwan. "Theory and VLSI Implementation of Asynchronous Sample-Rate Converters." 94th Convention of the AES, Berlin, Germany (16-19 March 1993); Preprint 3570.

(continued on page 44)

Analog Electronics: More Power Amplifiers, Preamp/Control Units, and Mild Surprises

By David A. Rich, Ph.D.
Contributing Technical Editor

This is the continuation of our ongoing preamplifier and power amplifier surveys. The plot thickens but does not take altogether new and different directions.

The reader is referred to Issues No. 18 and 20 for introductory material, basic definitions, general engineering concepts, circuit illustrations, and extensive reference documentation on the subject of preamplifiers and power amplifiers. Our first-time explanation of the PowerCube, with five typical examples of measurement printouts, is also in Issue No. 20. We cannot go over this groundwork in each issue for new readers, but both No. 18 and No. 20 are still available as back issues for subscribers.

Stereo Power Amplifier **Harman Kardon PA2400**

Harman Kardon Incorporated, a Harman International Company, 8380 Balboa Boulevard, Northridge, CA 91325. Voice: (800) 343-9381. Fax: (818) 893-0626. PA2400 stereo power amplifier, \$1199.00. Tested sample on loan from manufacturer.

Harman Kardon is not among the names that instantly come to the mind of an audiophile when he thinks of the high end, but perhaps it should be, since this company attempts to design its circuits according to the same engineering philosophy we see in the highest of high-end products. Harman Kardon circuits are always discrete. The circuit topologies use minimum feedback or no feedback at all. What principally separates a Harman Kardon audio component from a card-carrying high-end unit is build quality and price.

The front end of the Harman Kardon PA2400 power amplifier is much more complex than is typical for an amplifier in this price class. A floating current source is formed with three bipolar transistors. The two outputs of this current source are mirrored with a two-transistor Wilson (very high output impedance) current mirror to the complementary differential pairs. The supply rail for the current sources is provided by a pair of regulated supplies. Open-loop emitter followers set by self-biased zener diodes form the regulators. The differential pairs are

formed by source-degenerated JFETs that are cascoded by bipolar devices. The common-mode points of the two differential pairs are connected together through a 2.2 μF capacitor. This capacitor allows the amount of current flowing through the differential pair to increase if the amplifier approaches slew-rate limiting. The bases of the cascodes are connected to a level-shifted version of the common-mode voltage of the differential pair. This is called a dynamic cascode, since the emitter of the cascode device moves with the common-mode voltage of the differential pair. The dynamic cascode keeps the drain-to-source voltage of the differential pair constant in the presence of a common-mode voltage. This prevents the common-mode input signal from coupling to the output of the differential pair through the gain devices. Only one other maker of commercial amplifiers I have seen uses a dynamic-cascode input stage, and that is PS Audio. Bob Odell worked for Harman Kardon before he designed these PS Audio amplifiers, so it is likely that the technique originated at Harman Kardon.

The PA2400 is configured as a noninverting amplifier, as are nearly all other amps. Such an amplifier has a common-mode swing which is equal to the input signal. Recall that the differential input signal to the amplifier is an error signal which the amplifier tries to keep as small as possible. If the amplifier could keep the error signal at zero, the output would contain no distortion products, since the output/input transfer function would be controlled by feedback resistors alone. In an ideal differential amplifier stage, the common-mode signal is completely rejected. Now, if the differential pair transmits some of the common-mode signal to the second gain stage, that stage will be unable to distinguish between a signal resulting from the differential gain of the differential pair and a signal resulting from the common-mode gain of the differential amplifier. Consequently the output will be distorted because the amplifier no longer attempts to keep the differential input signal to a minimum.

THE AUDIO CRITIC

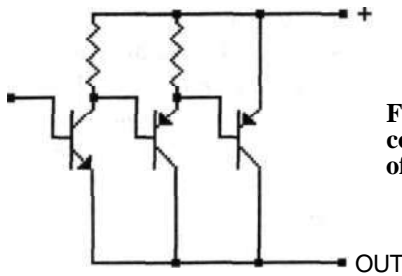

Figure 1: "Triple compound" topology of output stage.

The separation of the differential inputs occurs as the amplifier responds to the common-mode signal. Note that the small-signal common-mode gain of a differential pair usually varies across the common-mode voltage range of the amplifier, adding to the distortion effect. The dynamic biasing of the gain devices and the very high output impedance of the current sources ensure that the PA2400 input stage has excellent common-mode rejection ratios. A complementary differential input stage of a power amp can be formed with as few as four transistors, but the advanced stage developed for the PA2400 uses a total of 17.

The collectors of the cascode devices are terminated to resistors. One side of the input stage is coupled to an emitter follower, which then drives the second gain stage. This isolates the first gain stage's output from the nonlinear load of the second stage. The second gain stage is a composite *CE-CC* device often called a Darlington transistor [Gray and Meyer 1984]. This dual device can source significantly higher current than a single transistor. The balanced pair of Darlington devices are connected together through a single-transistor V_{BE} multiplier.

The output stage is novel, since it is in effect a complete unity-gain feedback amplifier embedded inside the complete amplifier. (See Figure 1, which shows a simplified schematic of one side of the amplifier.) Input signals to the first stage go through a common-emitter amplifier with a resistive load connected to the respective power rails. This is followed by an emitter-follower stage, which then drives the base of a common-emitter output stage. Connecting the collector of the follower stage to the output increases the complete subblock's current gain. The unity-gain feedback is established by connecting the output of the amplifier to the emitters of the first stage of the output stage. This local feedback arrangement linearizes the output stage, but stabilizing it is very difficult. Indeed, this stage may be thought of as a three-stage composite output device, and even two-stage composite devices are known to have stability problems [Gray and Meyer 1984]. Bongiorno called this topology a triple-compound device [Bongiorno 1984]. In his article he notes that it has the lowest distortion of any three-stage output device but calls it virtually impossible to stabilize. Harman Kardon engineers have been able to stabilize it, but no circuit trick is obvious from the schematic. Harman Kardon's rationale for the output stage is that linearizing it with the local feedback loop allows the amount of global feedback to be reduced. Some propo-

ISSUE NO. 21 • SPRING 1994

ponents of low-feedback design would argue that an internal multistage subblock operated at a high feedback rate constitutes cheating. Biasing the output stage is simple, since it can be seen from Figure 1 that the total output stage looks like a single *npn* transistor with very high current gain supplied by the last two stages of the circuit. The dominant pole of the complete amplifier is established by 47 pF capacitors across the *BC* junction of the first stage of the output circuit. Numerous other passive networks are also used to improve the amplifier's stability, among them an inductor in series with the output to improve stability into capacitive loads. The amplifier is completely direct-coupled, with a potentiometer in the circuit to null out any dc offsets. The pot adjusts the relative bias currents that flow in the two halves of the complementary amplifier. Unlike a dc servo, this arrangement can drift with time. The advantage to the highflier—oops, I mean the high-ender—is that the amplifier is flat to dc and no additional electronics are connected to the summing junction.

The large, single, toroidal power transformer has dual secondaries, one for each channel. The secondaries can be reconfigured for higher supply voltages by means of a rear-panel switch, labeled 4 / 8 . The higher voltage in the 8 . position allows for higher power output into load impedances of 8 ohms or more. With speakers of lower than 8-ohm impedance this 8 option should not be used; the amplifier's heat sinks and output stage are not adequate to deal with the dissipated losses that result when the amplifier delivers high power into the low-impedance loads. This is an interesting design compromise, since the advantages of a higher power rail can be offered for 8-ohm speakers, but the amplifier cost can be kept relatively low by not having to use a larger output stage. Separate full-wave rectifiers and filter caps are used for each channel; 12,000 μF of capacitance filters each supply rail.

The layout of the PA2400 looks so strange at first, it could be the audio equivalent of a *Car Talk* puzzler. A huge heat sink for the output devices is at the center of the chassis. RCA input plugs and a small PC board for the bridging and autostart circuits are located at the far side of the chassis, about as far from the low-level signal board of the power amplifier as you can get. A good part of the chassis is empty. The answer to the puzzle is that this chassis is also used for an integrated amplifier (HK6950R). Good-sized heat sinks are used on the pre-drivers and also on the full-wave rectifiers. A double-sided PC board mounted to the heat sink interconnects the output devices. Offset from this PC board is another PC board which incorporates the low-level electronics. This one is, disappointingly, a single-sided board.

The protection circuitry of this amplifier activates when an overcurrent or overtemperature condition occurs. The protection circuitry is also used during amplifier startup. When tripped, this circuitry shorts the ampli-

fier's input to ground and turns off the floating current sources so that no current flows in the amplifier stages. This is a good approach to protection against excess input voltage or output shorts, but it will not save your speaker if an output transistor shorts to a supply rail. (The protection circuitry in the Parasound amplifier—see below—would save the speaker, since it has a relay in series with the output terminals.) A unique auto-on feature allows the amplifier to remain powered on at all times; in this standby mode the floating current sources are turned off so current flow from the amplifier is minimum. When a signal is present at the amplifier's input, a circuit turns on the floating current sources and thus activates the amplifier.

Our laboratory measurements yielded the following results: Into an 8-ohm resistive load via the high-voltage secondaries, the PA2400 reaches a minimum THD + N level of -83 dB at 170 watts with a 1 kHz input just before clipping. No dynamic distortion is visible; i.e., the THD + N curves are almost exactly the same for all frequencies. Elimination of dynamic distortion (TIM, SID, etc.) is an important design goal for this amplifier and appears to have been met. Into a 4-ohm resistive load via the low-voltage secondaries, the minimum THD + N level at the onset of clipping (190 watts) is -74 dB. Again no signs of dynamic distortion can be seen, but the overall distortion level is relatively high; such static distortion dominates any dynamic effects. The PowerCube system measured a dynamic output voltage of 46.2 V (267 watts) into 8 ohms in the high-voltage secondary mode. This represents a dynamic headroom of 0.65 dB at 8 ohms relative to the continuous power output of this amplifier at 1% distortion (230 watts, significantly higher than at the start of clipping, because clipping in this amplifier is relatively soft). The PowerCube showed that in this mode the maximum voltage output of the amplifier into nonreactive loads declined by 7% into 4 ohms, 19.5 % into 2 ohms, and 37.5% into 1 ohm. In the low-voltage secondary mode the PowerCube system measured a dynamic output voltage of 36.3 V (165 watts) into 8 ohms and 34.3 V (294 watts) into 4 ohms. For the 4-ohm reading this represents a dynamic headroom of 0.53 dB relative to the continuous power output of the PA2400 at 1% distortion (260 watts, again higher than at the onset of clipping). In this alternate mode the PowerCube showed that the maximum voltage output of the amplifier into nonreactive loads declined by 5.5% into 4 ohms, 18% into 2 ohms, and 34.5 % into 1 ohm. Dynamic output voltage into reactive loads was at all impedances and in both modes equal to or higher than that into the resistive load, confirming that the amplifier's protection circuitry does not affect its performance and that the amp is very stable into complex loads. In other words, the PA2400 drew an excellent PowerCube.

So what we have here, on balance, is a power amplifier priced \$99 higher than the Rotel RB-990BX re-

viewed in the last issue but less powerful. Build quality in the two amplifiers is similar. The Harman Kardon PA2400 does have better protection circuitry and has the autostart feature. What it also gives you is classic high-end design, with a complex circuit topology that uses low feedback and has no coupling caps. Dynamic distortion is nonmeasurable but static distortion is up a little in comparison with the Rotel. If you believe that feedback is the causative agent of some kind of mysterious sonic pathology (I do not), then purchase the PA2400; it will be as free from the mystery disease as amplifiers blessed by the high-end crowd at more than twice the price. But if I had to make the choice, I would pick the more powerful Rotel.

Full-Function Preamplifier

Harman Kardon AP2500

Harman Kardon Incorporated, a Harman International Company, 8380 Balboa Boulevard, Northridge, CA 91325. Voice: (800) 343-9381. Fax: (818) 893-0626. AP2500 stereo preamplifier, \$599.00. Tested sample on loan from manufacturer.

Like the PA2400 power amp reviewed above, this Harman Kardon preamp is conceptually a true high-end design, even though it costs an order of magnitude less than some audiophile preamps whose electronic design is no more complex nor more faithful to the audiophile doctrine of discrete circuits and low feedback. How does Harman Kardon do it? Build quality is similar to that of other consumer products, for one thing, instead of MI tanks, and profit margins are set to be consistent with those of other large consumer-electronics companies, not fashion boutiques. The AP2500 is the successor to the Citation 21, reviewed in Issue No. 18.

This is a full-function preamp incorporating a phono preamp with optional gain for a moving-coil cartridge. The unit has six high-level inputs. Two tape monitor outputs are available. The AP2500 does not have tape monitor buffers, so the tape monitor outputs are connected directly to the selected input. You should always turn on all tape recorders even if they are not in use, since they may present a very nonlinear load to the input if they are left off. A separate three-position switch connects the tape monitor outputs to the line outputs. Copying from Tape 1 to Tape 2 is possible but not the other way around. No record function selector is included, so you must listen to the same program you are taping. Putting a tape recorder into a self-connected loop is not possible with the AP2500; potential system-destroying oscillations are thus prevented.

As there are a lot of circuits to go through, let us start at the moving-coil stage, which is a minimal complementary differential amplifier with six transistors. No cascodes, active current sources, or emitter followers here. Because of its high output impedance, this stage is

THE AUDIO CRITIC

more accurately described as a transconductance (G_m) amplifier. The MC amp is supplied by separate open-loop emitter follower regulators. The zener diodes are biased by JFETs configured as constant-current sources to ensure the good power-supply regulation required for high-gain amplifiers. Other regulators in the amplifier only have the diode biased by a resistor connected to the unregulated supply. The MC stage is selected or bypassed by a standard pushbutton switch, which may not be the most reliable approach to handling low-level signals. The RIAA amplifier is another six-transistor G_m stage. As was the case with the Citation 21, the RIAA feedback network loads the output stage of the amplifier and is thus compensating it for stability by shaping the amplifier's open-loop gain. This approach keeps the return feedback rate constant—well, at least at higher frequencies; at lower frequencies the amplifier's internal output impedance starts to dominate and its open-loop gain becomes a constant. Since the RIAA curve rises until 50 Hz, the return loop gain starts to decline at low frequencies. Problems caused by this decline will be seen in the measurements discussed below. A more complex gain element than the minimal six-transistor design is needed to allow this circuit to work properly at low frequencies. A passive RC network follows to cancel the added transmission that occurs when a noninverting amplifier is used for the RIAA equalizer (see Issue No. 18). Following next is a composite two-stage bipolar amplifier configured as a unity-gain buffer with a pullup resistor. All three coupling capacitors are used in this stage. A bipolar device shorts the output of the stage to ground on power-up. The stage is powered by an open-loop regulator using a similar composite device.

The line-level preamp section starts out with a gain stage which precedes the volume control. The gain of this stage is switched by paralleling another resistor with the feedback resistor, which is connected from the minus input to ground. The gain switching is accomplished with a JFET active switch. The front panel switch thus does not switch the analog gain directly but only sets the dc value to the JFET switch. No additional noise or crosstalk components occur with dc switching. Placing the gain stage ahead of the volume control also improves the amplifier's signal-to-noise performance, since at reduced volume setting the signal level and the self-noise of the amplifier are reduced. If the amplifier followed after the volume control, its output noise would be a constant, independent of the volume control setting. The problem with the approach used in the AP2500 is that the signal swing at the input to the volume control can be very large, because the gain now precedes the volume control. This can result in increased distortion. Being able to select the gain of this stage (2.5 dB or 13.5 dB) helps minimize this problem, as do the ± 28 V regulated supply rails delivered by another pair of open-loop emitter-follower regulators. The active stage for this amplifier is a truly

minimal four-transistor single-ended G_m stage. If it were a true voltage amplifier, the resistance of the volume control could be reduced to improve crosstalk and increase bandwidth (as was done in the Boulder "Ultimate" preamp), but the G_m stage can only drive a 30 k Ω pot. Other than the Boulder, the only preamp we have examined with an active predriver for the volume control is the Krell KRC-2, but the KRC-2's stage is unity-gain. The coupling capacitors C_1 and C_3 are used in this stage, but not C_2 . (See Issue No. 18, p. 18.)

The volume control is a high-quality sealed Alps unit. The unit has no balance control. Following the volume control is another four-transistor G_m cell set for a gain of 2 dB. This is followed by another two-transistor, open-loop, resistively biased buffer, which is connected to the preamp's outputs. In the Citation 21 review, I complained that the G_m cell (which in that model was a much more complex, fully balanced circuit) was driving the load directly. The addition of the follower corrects this, but its single-ended, resistive biasing will make it difficult for this stage to drive low-impedance loads. Now, Harman Kardon does know how to produce a good discrete amplifier that can drive a low-impedance load; indeed, they have one in this preamp: the headphone amplifier, which is an eight-transistor amplifier with a push-pull Darlington output stage inside the feedback loop. Why a similar circuit is not used for the line-output amplifier is beyond me. The output is muted on power-up by a bipolar pulldown. This is a feature that all preamps should have but many four-figure models do not. Again, the coupling capacitors C_1 and C_3 are used in the output stage, but not C_2 . The headphone amplifier and line driver are powered by another set of open-loop regulators with two-transistor composite drivers. That brings the total number of regulators in this preamp to eight. Interestingly, the Citation 21, which also had eight regulators, used a combination of four-transistor discrete closed-loop regulators and open-loop subregulators.

In the low-gain setting the line stage reaches a minimum distortion of -90 dB at 3 V rms, rising to -78 dB at 8 V rms, where clipping starts. No dynamic distortion is visible in these curves; the distortion figures are basically frequency-independent. In the high-gain setting low-frequency distortion was similar, but the 20 kHz distortion curve started to deviate slightly from the low-frequency curves at 2 V rms. Adding a 600-ohm load shows that the output buffer has trouble, as expected, driving a low impedance. Soft clipping starts at 1 V rms with a distortion figure of -85 dB, and at 2 V rms output the distortion rises to -40 dB. Again, no dynamic distortion was visible in the 600-ohm test. Channel separation is exceptional, staying between 107 dB and 105 dB from 20 Hz up to 1 kHz and diminishing to 80 dB at 20 kHz. The lack of a balance control helps in achieving this result, but exceptionally careful layout of the single-sided PC board is also required to obtain such numbers. Only 2

to 4 μV of 60 Hz hum and less than 2 μV of 180 Hz hum were found at the line outputs (low-gain setting at full gain), confirming that all the regulators are doing their job. [The headphone amplifier was not measured, a truly regrettable omission for which I'll have to take the rap.—Ed.]

The phono stage does not perform as well. The RIAA equalization error curve in the worse channel occupied a strip almost 0.5 dB wide, and channel matching was off by as much as 0.2 dB at some frequencies. A 0.3 dB rise in the response from 100 Hz down to 20 Hz is probably due to inadequate loop gain at low frequencies, a result that we expected from the circuit analysis. The other systematic variations in the RIAA response are probably due to nonoptimal selection of the RIAA passive components. Distortion tests of the phono stage showed significantly higher distortion at 20 Hz than at 20 kHz, confirming the inadequacy of the loop gain at low frequencies. Measured at the tape monitor output, the 20 Hz distortion reaches a minimum of -68 dB at 1 V rms, rising to -45 dB at the 11 V clipping point. The 20 kHz distortion curve is at a minimum of -82 dB at 5 V rms and rises only slightly to -74 dB at 10 V clipping. These are the figures for the moving-magnet stage; the moving-coil stage appeared to introduce no significant additional distortion. The worst-case input-referred noise of the MM stage was relatively high at 1.5 μV ; the MC stage had an input-referred noise of 0.38 μV .

Build quality is similar to that of other up-market Japanese-made components. The PC board is single-sided. The PC-board-mounted RCA jacks are gold-plated only on the ground side. The selector switch is mounted near the rear of the unit. It is a linear switch, with a smallish rotational-to-linear converter mounted in front. The shielded transformer is relatively large for a preamp. Regulator pass transistors are on good-sized heat sinks.

The phono performance of the AP2500 is significantly worse than that of the 8% lower-priced Rotel RC-980BX, but the Harman Kardon marginally outperforms the Rotel at line level. The line-level channel separation of the AP2500 is truly exceptional. Build quality of the two units is similar. The AP2500 is an all-discrete low-feedback design, whereas the Rotel uses op-amps. A difficult choice, but I would save the \$49 and go with the Rotel. If a phono stage is not a requirement, then the Accurus L10 becomes the clear choice (among the preamps we have tested so far), since it is much better built than the other two units and is priced the same as the Harman Kardon. More expensive preamps by B&K, Bryston, and Sumo should also be considered (see Issue No. 18).

Line-Level Remote Preamplifier

Krell KRC-2

Krell Industries, 35 Higgins Drive, Milford, CT 06460. Voice: (203) 874-3139. Fax: (203) 878-8373. KRC-2 remote-38

controlled line-level preamplifier, \$3700.00. Tested sample on loan from manufacturer.

I have invoked the name of Krell in these pages many times, but this is the first time since Issue No. 10 that we have had a new unit made available to us for testing. At \$3700 the KRC-2 represents the middle price point in Krell's \$2700 to \$6300 line of preamplifiers (without phono). It is not a tweaky update with Wonder Caps of a 1950s circuit design but a fully modern remote preamp under microprocessor control. So it's an overpriced Sony? Far from it; the build quality is close to mil-spec, and the analog circuits are all discrete with low or no feedback. Indeed, the Krell topologies are unlike anything else on the planet, as we shall see below. [On our planet, yes, but what about the Forbidden Planet? (Inside joke.)—Ed.] This is a line-level-only preamp with two balanced and four unbalanced inputs, one balanced and one unbalanced output. There is only one unbalanced tape-monitor loop, and it can record only the source connected to the main outputs. Input and tape switching is by relays controlled by a microprocessor. Selecting an unbalanced input causes the negative input of the preamp's balanced input buffer to be grounded. No tape-monitor buffer is included. So, if you want multiple tape loops, an independent tape-function selector, and a tape-monitor buffer, you will just have to save \$3001 and purchase the Sumo Athena II.

As I said, the circuits look to me as though they might have come from a Martian E.E. They look so strange because the designers are obviously trying to optimize them for some performance attribute that is different from the standard goals of low static and dynamic distortion. Note that they are not just trying to design a high-performance preamplifier in the traditional sense with low or no feedback. To do that, you use fully complementary circuits, dynamic cascodes, nontraditional methods of canceling distortion such as feedforward and the Hawksford circuit, etc. An example of this approach can be seen in the Tandberg TCA-3018A preamp.

Okay, so what's inside the KRC-2? The first sub-block is a buffer stage which uses no feedback. This decouples the input signal from the load presented by the programmable volume control. First, the input signal sees two source-degenerated JFETs with resistive loads (one JFET for each polarity of the signal). This stage provides a 10 dB loss (!!?) and rereferences the signal to the positive supply rail. Following that is an emitter-degenerated bipolar stage biased with a single transistor current source. This stage is loaded with a resistor, with a resultant gain of 7 dB for the stage. The dc bias on the bases of both transistors is several volts below the supply rails, limiting the dynamic range of the stage. In series between the gain element and current source is a stacked set of diodes, which are used to bias a set of complementary emitter followers. The dc offset of this stage is canceled

THE AUDIO CRITIC

by a dc servo. Identical circuits are used for the plus and minus signals. No circuit is included to convert a single-ended signal to balanced.

The volume and balance controls are formed by a resistor ladder and CMOS switches. The schematic of this stage was not submitted to us, but with proper design the CMOS switches can be arranged so that no static current flows through them when terminated into a buffer stage. But even under these conditions some distortion can occur at high frequencies. This distortion is the result of a voltage divider formed by the nonlinear channel resistance of the MOSFET and the nonlinear reverse-biased diode that is the drain of the MOSFET. The catch is that if the width of the MOSFET is increased to lower the channel resistance, the parasitic capacitance grows proportionately. Using a device with a lower channel length will reduce the on resistance without increasing the parasitic capacitance, but the magnitude of the voltage that can be passed through the device decreases because small channel devices have lower breakdown voltages. The on resistance of the channel of the MOSFET varies with the gate-to-source voltage and hence the signal swing. For the case of an NMOS device, the channel resistance increases with increasing signal voltage. Fortunately a PMOS device does just the opposite. By using both types of CMOS devices in parallel, the variation in channel resistance is minimized, especially when the input signal is kept well below the gate voltages on the CMOS switches. The disadvantage of CMOS is that if the signal ever goes above the chip's supply voltage, the chip can go into destructive latchup. It is therefore important to clamp the input signal to the CMOS gates by means of Schottky diodes. Without a schematic I cannot tell what Krell does to prevent latchup.

The output of the volume-control circuit goes into a unity-gain follower with no feedback. The follower is required because the CMOS switches cannot be resistively loaded, as explained above. You would logically expect this buffer to be similar in topology to the buffer on the input, since they perform similar functions, but you would be wrong. This buffer's first stage is a JFET source follower biased by a single-transistor bipolar current source. Stacked diodes are in series between the follower and the current source; the stage then drives a complementary emitter follower. A separate follower is used for each of the balanced signal lines. The output of this buffer stage has a significant dc offset, which is rejected at the input of the next stage, since dc offset is a common-mode signal to this stage. The output of the buffer is routed into a balanced amplifier using a classic all-bipolar complementary op-amp. The differential pairs are biased by current sources, and cascaded emitter followers are used for the output stage. A dc servo removes the dc offset at the output. One op-amp is used as a differential-to-single-ended converter (see the Parasound power-amplifier review for more on this circuit) for the plus out-

ISSUE NO. 21 • SPRING 1994

put, and a second op-amp is used in an identical circuit except for reversed inputs for the minus output. Why a true balanced op-amp (two inputs and two outputs) was not used here instead of the two single-ended op-amps is unclear to me, but that is not the strangest thing about this output stage. The strangest thing is the way its gain is set.

Consider the feedback equation $G = A/(1 + AB)$, where G is the closed-loop gain, A is the open-loop gain, and B is the fraction of the output that is subtracted from the input. The Krell's output amplifier has a low-gain mode and a high-gain mode, switched by a relay. The high-gain mode doubles the G . In the low-gain mode the open-loop gain A is approximately 6 (the gain stages are highly degenerated and heavily loaded), but the external feedback resistors that determine B are set for a closed-loop gain G of 10. Clearly you are not going to get any more gain out of the amplifier than its open-loop gain A , although the presence of the feedback loop does have a slight effect on the closed-loop gain G . Now, you are not going to believe what that gain-switching relay changes. No, it doesn't change B ; it changes the open-loop gain A , which no other designer would touch in this application. It does this by reducing the emitter degeneration of the first stage, so that the open-loop gain is now increased to approximately 25. So what we have here, friends, is an output stage that has just a little feedback in the high-gain mode and virtually no feedback in the low-gain mode! (I told you the design came from another planet.) Finally, the output stage is connected through a muting relay to the output jack. This prevents turn-on and turnoff pulses from getting to the output. This important feature often does not show up in megabuck preamps. The muting function is automatically engaged on power-up; you have to disengage it before you can select an input.

The thick, high-quality sheet metal of the KRC-2's chassis is what is expected at this price point; it is perforated with many closely spaced slits on top and on the sides for both lightness and ventilation. Inside is a wall-to-wall 4-layer PC board stuffed with components. RCA jacks are mounted directly to the rear chassis for added structural integrity. Right-channel jacks are connected directly to the main board. Left-channel jacks are connected to an auxiliary PC board mounted above the main board at the rear of the unit. This board contains the left-channel relay network.

The ac power line comes right onto the main board and into the big (for a preamp) PC-board-mounted transformer. All the circuitry shares the same power-supply regulators. This is not a dual mono design!! Each half of the power supply has its own bridge rectifier and 4700 μ F filter cap. The voltage reference is a zener diode biased from the unregulated rail by a resistor. This is then filtered by an RC network. The regulator itself is formed with an OP-27 op-amp which drives the base of a bipolar pass transistor and receives an attenuated version of the

regulated rail on its negative input. The reference voltage is connected to the plus input of the op-amp. The regulator is configured as a tracking regulator, so that the positive power supply acts as the reference for the negative supply. The TO-3 packaged pass transistor is on a big heat sink. The supply for the microprocessor and other circuitry used for the remote control is on a separate transformer secondary and has 7812 and 7805 integrated regulators. These regulators are also on good-sized heat sinks, as are all the output devices.

The remote-control features of this preamp are no gimmick. Once you have experienced the ability to adjust signal levels at the listening position, you will never want to go back to a preamp without a remote. The microprocessor-based circuitry for the remote control is essentially similar to that used in other remote-control products. In less expensive products much of the signal switching would be done with semiconductor devices, not the 18 relays used in this unit. A shaft encoder is used to simulate the action of a rotating volume control. In a high-volume product the selector pushbuttons and display devices would be a custom implementation that would cost significantly less per unit, but at very low volume the tooling cost would make production of such units prohibitive. In the KRC-2 these components are all on a PC board mounted to the front panel. Even the handheld pushbutton control unit for the KRC-2 is manufactured by Krell in the USA. Unfortunately, without custom tooling the remote control is somewhat large and cumbersome. The code for the microprocessor still needs some work. The balance control requires that the L or R pushbutton be pressed each time to advance it, but the volume control advances only if the Level button is pressed continuously. A pop could be heard through the speakers when the Gain button was pressed to switch between low and high gain. This indicated the intrusion of dc offset when switching, a bug that should have been cleaned up before the preamp was put into production. The gain setting of the preamp would occasionally change arbitrarily when the unit took a static discharge hit. (Sonys do not do this.) The feel of the shaft-encoder-based volume control, however, is excellent. The same cannot be said of the power switch because this preamp hasn't got one!! This is unacceptable, given the power dissipation of this unit. *[Come on, David, you know the rules of the high-end game. Preamps must be powered up 24 hours a day, 365 days a year, otherwise they won't sound good. They begin to sound really good only after several weeks, or is it months? —Ed.]*

The Krell KRC-2 showed no dynamic distortion in our tests, but overall distortion was quite high for a preamp, even if not nearly high enough to be audible. With an unbalanced input and unbalanced output in the low-gain mode, THD + N reached a minimum of -81 dB at approximately 1 V rms output, then rose to -60 dB at 7 V rms, just before clipping. The Harman Kardon

AP2500, also reviewed in this issue, did significantly better in the THD + N test, even though it sells for less than one sixth the price of the Krell. Since the AP2500 is also a low-feedback design, Krell cannot use the old "you can have very low numbers only if you pour on the feedback" excuse. Distortion was very similar in both gain modes and was unaffected by a 600-ohm load across the output. (That is one test where the AP2500 does not do nearly as well, since it lacks the big output stage of the Krell.) Distortion with a balanced input and balanced output was better, since even-order distortion products cancel in the balanced mode (provided the power-amplifier input stage has as good a CMRR specification as our Audio Precision test unit). When the input was single-ended but the output measured in the balanced mode, the distortion was very close to the measurements for unbalanced in and out. That was predictable because with a single-ended input only one set of buffer stages sees a signal; the other set is at ground, since this preamp does not have a single-ended-to-balanced converter. Consequently these stages operate single-ended and distortion cancellation does not occur. The THD + N in the low-gain mode with a balanced input and balanced output reached a minimum of -89 dB at 3 V rms differential (1.5 V on each lead) and was -65 dB at 14 V rms differential, where the stage clips. Running the test with a balanced input and single-ended output yielded similar distortion results (the output amplitude was of course reduced by a factor of 2). This indicated that the principal distortion is not occurring in the output stage. Easily measurable hum components (7 μ V at 180 Hz and 5.5 μ V at 300 Hz in the low-gain mode with the level control at full gain) contaminate the single-ended output. The lowly Harman Kardon AP2500 has significantly smaller hum components and a lower noise floor. Channel separation of the KRC-2 runs from -123 dB at 20 Hz to -66 dB at 20 kHz. Again, the Harman Kardon beats the Krell above 500 Hz. This despite the Krell's four-layer boards, electronic attenuators, and a fully balanced internal signal path. (When an adjacent channel couples into both the plus and minus signal leads, it represents a common-mode signal and should be rejected.)

Is the Krell KRC-2 a rip-off? No, it isn't, since its price is consistent with other low-volume, retail-marketed audio products of similar build quality and complexity. This should be the last preamp you will ever have to buy, something you probably cannot say of the Harman Kardon AP2500. It is interesting to point out that just minor modifications to the KRC-2's circuits to increase the feedback levels would reduce the distortion significantly. But as I said above, it is clear that the engineers are designing to some set of parameters I do not understand. One presumes that they think they are optimizing the sound quality of the preamp, but we could hear absolutely no difference in matched-level ABX testing against other units. Krell cannot, however, make up any

THE AUDIO CRITIC

excuses for the significant hum components and less-than-outstanding channel separation in a \$3700 preamplifier. At this point in time, the KRC-2 is the only remote-controlled preamp with balanced inputs/outputs and built-for-life construction at or below this price (unless others have appeared since this was written). If you need those features, can overlook the occasional switching pops, can live with the somewhat inconsistently operating remote control, and have the funds—well, then go ahead and buy it. I, from my perspective as a terrestrial E.E. and audio consumer advocate, cannot endorse it with any degree of enthusiasm.

Stereo Power Amplifier

Parasound HCA-2200II

Parasound Products, Inc., 950 Battery Street, San Francisco, CA 94111. Voice: (415) 397-7100 and (800) 822-8802. Fax: (415) 397-0144. HCA-2200II Ultra High Current Power Amplifier, \$1695.00. Tested sample on loan from manufacturer.

This is a big brute of an amplifier that is sold by dealers as equivalent to a Krell or a Mark Levinson at a fraction of the price. Before I analyze the truth of such a statement I must digress with a story about how your friendly audio dealer operates.

I occasionally hang out at audio stores to see how the salespeople do their job. On one occasion a man walked in and showed interest in the HCA-2200. The dealer immediately went into the "this amp is just like a Krell but costs a lot less because Krells are overpriced" speech (he was not an authorized Krell dealer). The dealer then hooked the unit up for a listen, and proceeded to pour on the "sweet high end, great imaging" shtick, hoping for a quick sale. "Did I mention it was designed by John Curl, who used to work for Levinson?" he droned on. The customer wanted to hear how the Parasound sounded against a megabuck unit the dealer had on display. The dealer tried to discourage this, wanting to close the sale quickly, but when it was clear the customer was not going to produce his credit card instantly, the dealer set up the demo (without level matching, of course). During the demo the dealer pointed out how similar the units sounded, but the customer disagreed, preferring the higher-priced unit. When it became plain that the customer had the funds to buy this megabuck amp and had been shopping for similarly priced units at other stores, everything changed. Now the HCA-2200 had a sloppy bottom end, a shrinkage of the soundstage width, lack of definition on the highs...

Much of the 60 lb. weight of the HCA-2200II is from the thick sheet metal of its chassis, its large heat sink, and its big power transformer. So from outer appearances this amp does appear competitive with higher-priced units. But open the chassis and you find yourself staring at a single-sided PC board, which contains most

of the amplifier's electronics. It is mounted on the rear. Other, smaller boards, which contain power-supply components and which interconnect the output devices in the unit, are double-sided. Wiring appears to be untidy. Cheap push connectors without gold-plating were used in many places to connect the wiring harness. A large number of capacitors were tack-soldered onto the backs of other capacitors instead of being properly mounted directly on the PC board. Many construction flaws can be noted, including several components with bent leads. This probably occurred when the PC board was quickly squeezed into the tight space allotted for it. Next to an underfilled soldered joint was another joint with a giant solder blob (apparently a sloppy piece of rework). To sum up, this unit is better built than the best Radio Shack receiver but is not built to the standards of Krell or, for that matter, Mondial and B&K.

Where value can be found is in the circuit design of the HCA-2200II. The two voltage-gain stages are supplied by separate regulated power supplies. The huge transformer has four separate secondaries. Two are for the output stage, one per channel. The other two are at a higher voltage for the voltage-gain stages of the amplifier. Again these two secondaries allow for dual-mono configuration. Each secondary is followed by a full-wave rectifier. Each unregulated output supply rail is filtered by a 25,000 μ F electrolytic capacitor plus three 0.1 μ F and six 0.01 μ F capacitors. One or two small film capacitors are used as bypass caps to shunt the inductance of the large electrolytic, but the nine (three plus six) small capacitors must be used for some tweeko reason that I cannot fathom. To add insult to injury, all the film bypass capacitors are connected before the rail fuses—but if they are to have maximum effectiveness, they should be connected after the fuses. The transformer secondaries for the voltage amplification stage must be at a higher potential than the unregulated output stage, since the voltage regulator will reduce the potential of the supply and the regulated-supply output must at least be at the potential of the unregulated output supply rail. Regulation on the voltage rails is accomplished by an open-loop emitter follower. Stacked zener diodes are connected to the base of the follower. The zener diodes are biased by a resistor connected to the unregulated supply. A more complex regulator would offer better power-supply rejection and lower output impedance, but such a circuit is not a trivial or inexpensive design when 76 V regulated rails are required.

The actual amplifier is a relatively straightforward design. Complementary differential pairs with JFETs form the first stage. The n -channel sources are connected to the p -channel sources through a resistor network. Because the JFETs have a negative threshold (for the n -channel devices), this arrangement self-biases the differential pairs. Unlike a constant-current biasing scheme, such self-biasing allows the current in the differential

pair to increase when the differential pair is driven with a large differential current. This improves large-signal dynamic performance. The resistor network also allows for some degeneration of the input stage. This arrangement, also employed in the Hafler Transnova amplifier (see Issue No. 20), apparently was developed by John Curl when he was working for the original Mark Levinson company. The differential stages are cascoded with bipolar devices, which in turn drive resistive loads.

An RC network across the collectors of the cascode devices is part of the amplifier's compensation network. The complementary outputs of the differential stage are then passed to a second set of bipolar differential pairs, which is the gain element of the second stage. One of the collectors in each of the complementary differential pairs in the second gain stage is connected to ground. The other pair of collectors is connected together through a complementary two-transistor V_{BE} multiplier. The use of a differential pair in the second gain stage improves the common-mode rejection ratio (CMRR) of the amplifier. A capacitor from one end of the V_{BE} multiplier back to the negative input of the op-amp sets the dominant pole of the amplifier. The output stage of the amplifier is a set of six paralleled bipolar output devices. Driving six bipolar devices on a 70 V supply rail is a difficult task for the predriver, since the base current requirements for the output stage can become very high when driving low-impedance loads. In the HCA-2200II a single MOSFET predriver in a source-follower configuration drives the output stage. As discussed in Issue No. 20, common-emitter stages exhibit less distortion than a MOSFET common-source stage when they are required to drive a significant load. An additional problem caused by mixing MOSFETs and bipolars occurs in biasing the bipolar output stage. Normally the temperature coefficient of the V_{BE} multiplier (which is mounted on the heat sink) matches that of the output stage, and thus the quiescent current of the output stage is independent of the output-stage temperature. When the MOSFET is used as a predriver, its temperature coefficient, which is different from that of the bipolar devices, will cause some variation in the quiescent current of the output stage. Through careful choice of bias currents, this effect can be minimized—

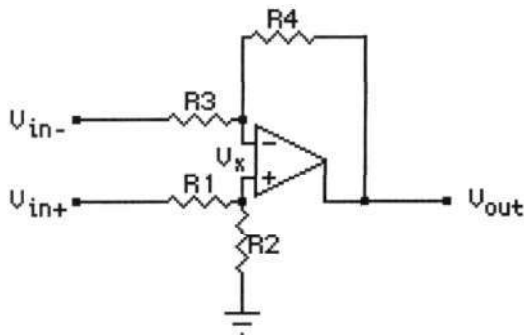

Figure 2:
Op-amp used as balanced-to-single-ended converter.

but get it wrong and the amplifier can go into thermal runaway at the drop of a hat. Since the Parasound did not blow up in our faces, I must conclude that they have the problem under control. A total of 28 transistors are in the active signal path of each gain stage. No capacitors are in the signal path. A dc servo removes dc offset from the output terminals.

A separate six-transistor circuit is used for the protection of the amplifier. The amplifier's dc offset, output-stage current, and heatsink temperature are all monitored. If any one of these exceeds preset levels, the protection circuit opens a relay in series with the speaker terminals. This forms a very effective protective circuit which does not affect performance during normal operation. Tweaks will roll their eyes into the back of their head at the thought of relays in series with the speaker terminals, but Parasound has wisely chosen to ignore the cultists and produce an amplifier which will not be accumulating frequent-flier miles between the owner and the factory for repairs required after output terminal shorts. In addition, if the amplifier should fail internally, the relay will protect your speakers.

In Robert Harley's negative review of the original HCA-2200 ("...slight grain overlaying midrange textures... The treble... a bit tizzy, with a dry forwardness... soundstaging...flat and congested...", etc.—*Stereophile*, April 1992), he complained about the presence of an AD712 op-amp as the balanced-to-single-ended converter. Perhaps the op-amp, lacking the blessing of the High End, predisposed him to write negatively about the amplifier's "sound." Such biases are unavoidable without blind testing. Given the outrageous fact that a bad review from Harley, no matter how unscientific, has a depressive effect on sales, Parasound apparently felt obligated to revise the amplifier and remove the op-amp. Unfortunately they replaced it with the simplest possible discrete circuit in the II revision, a two-transistor open-loop JFET buffer.

* * *

Before we go any further, we need to review how an op-amp can be used as a balanced-to-single-ended converter. This is as good a time as any to discuss how this circuit works. The circuit is shown in Figure 2. Its operation is easy to understand. The voltage at the summing junction of the op-amp is

$$V_x = \frac{R_2}{R_1 + R_2} V_{in+}$$

From the virtual ground property of the summing junction of the op-amp, the voltage V_x is also on the right side of resistor R_3 . The current flow in R_3 , which is also the current flow in R_4 , is then calculated as

$$I_{R_4} = I_{R_3} = \frac{V_{in-} - \frac{R_2}{R_1 + R_2} V_{in+}}{R_3}$$

The voltage at the output of the op-amp is then cal-

culated with $R_1/R_2 = R_3/R_4$ for simplicity.

$$V_{out} = -I_{R_4} R_4 + V_x = \frac{R_2}{R_1} (V_{in+} - V_{in-})$$

The last equation is just what we want: the difference of the input signals is amplified and converted to a single-ended output. Now we can build this circuit using an op-amp and place it ahead of the single-ended power amp. This is what was done in the original Parasound HCA-2200. Indeed, Parasound used an even better circuit, based on a two-op-amp balanced-to-single-ended converter, which had improved distortion performance.

An alternative is to use the power amplifier itself as the op-amp element. A problem with this second approach is that the input impedance of the negative terminal can be very low. From the circuit above it is easy to see that the input impedance of the positive terminal is $R_1 + R_2$, which will be a high value, but the impedance of the negative input terminal is much less. This impedance is calculated as

$$Z_{in-} = \frac{R_1 + R_2}{R_1 + 2R_2} R_3$$

For a high-gain amplifier, this can be approximated as $R_3/2$. Now, if we want the input impedance of the amplifier to be 50 k and the amplifier's gain to be 10, then R_4 is going to have to be 1 M, which is not a practical value. The solution is to use a smaller value of R_3 to bring R_4 down to a practical value. The low input impedance is dealt with by adding a voltage buffer in front of the negative input of the amplifier.

* * *

As I said, the two-transistor open-loop JFET buffer regrettably used by Parasound in the II revision is the simplest possible discrete circuit for this application. In its simplest form a diode-connected JFET forms the current source that biases the single-transistor follower stage. For matched devices the voltage drop across the biasing device matches the voltage drop across the source-follower device. Since the gate-to-source voltage of the current-source transistor is zero, the drop across the source-follower device is also zero, and the input and output voltages of the buffer are matched. In the Parasound implementation of the two-transistor buffer, a resistor is placed in series with each source of each JFET to reduce static current flow and improve matching. This simple circuit cannot follow the input signal accurately enough to transfer it without distortion, as we will see below, because an open-loop JFET source follower is not linear enough.

The bridged mode of the amplifier is also poorly implemented, in both the original version and the II revision. For the bridged mode to work, the input of one channel of the amplifier must be inverted with respect to the input of the other channel. Again, this is usually accomplished by placing an inverting amplifier, formed

with an op-amp, in front of one of the channels. The op-amps used in the original HCA-2200 could also have done double duty for this function, in a simple re-configured circuit, but apparently this was not done. The bridging circuit used instead has the output of the first amplifier routed not only to the output terminal but also to the second amplifier stage, which is reconfigured by the switch that selects the bridged mode to be an inverting unity-gain amplifier. Now, a unity-gain amplifier is harder to compensate than an amplifier with a gain of 20 dB, since the feedback factor is higher. The dominant pole of the amplifier must be moved to a lower frequency. The problem occurs when the amplifier is run in normal mode and the output stage is set for 20 dB gain. In such a case the amplifier is greatly overcompensated and its open-loop bandwidth is significantly narrower. The reduced open-loop bandwidth gives rise to significant dynamic distortion, as documented below.

Into an 8-ohm load driven from the unbalanced input, the HCA-2200II reaches a minimum THD + N level of -85 dB at 250 watts with a 1 kHz signal. Into 4 ohms with a 1 kHz input the minimum THD + N level at the onset of clipping (400 watts) is -80 dB. Above 1 watt the 20 kHz distortion curve flattens and then rises to -64 dB at clipping into 8 ohms. Into a 4-ohm load the 20 kHz distortion curve flattens out at half a watt at a level of -75 dB and then rises to -59 dB at clipping. These substandard dynamic distortion results are probably due to overcompensation of the amplifier for the bridged mode. Another sign that the amplifier is overcompensated is that, even though it has no inductor in series with the output, the damping factor starts to decline at 1 kHz. The damping factor is proportional to the amplifier's closed-loop gain. Interestingly, the dynamic distortion of the amplifier starts to increase above the static distortion at the same point, 1kHz. A secondary possibility might be that the MOSFET predriver is the source of the dynamic distortion.

Switching into the balanced input mode, the distortion figures degrade significantly as a result of the poor performance of the input buffer. THD + N with an 8-ohm load is the same regardless of frequency, reaching a minimum of -74 dB at 5 watts and then rising to -59 dB at clipping. The low-frequency distortion at clipping is thus degraded by the buffer by more than an order of magnitude.

The PowerCube measurements turned out to be another story. The PowerCube system measured a dynamic output voltage of 53.8 V (362 watts) into 8 ohms. This represents a dynamic headroom of 0.8 dB. The PowerCube showed that the maximum voltage output of the amplifier declined by only 11.5% into 2 ohms with non-reactive loads and by only 26% into 1 ohm. The dynamic power into a 1-ohm resistive load measured 1595 watts. The PowerCube measurements of voltage into reactive loads were in all cases equal to or higher than those into

the resistive loads. This amp thus proved to be extraordinarily stable into reactive loads. Peak current output was 198 amperes. The PowerCube therefore confirms that this is the most powerful amp we have tested so far. As for channel separation, we measured 90 dB or better below 1 kHz, gradually moving to 70 dB at 20 kHz.

To sum up, the Parasound HCA-2200II proved to be a very powerful amplifier, with a power transformer, output stage, heat sinks, and protection circuitry that are not underdesigned for the task. The presence of regulated supply rails and a dc servo indicates that the engineers have not skimmed on the design of the amplifier to meet a price point. On the downside, distortion performance was substandard as a result of some kludgy circuit design, although the distortion still is low enough to be inaudible. Construction quality has to be judged acceptable given the price and power output, but no more than that. Since this unit is slightly more powerful than the Rotel RB-990BX and significantly better protected, it can be recommended for special situations, but in most cases I would pocket the \$595 price difference and go with the Rotel.

Now, since Parasound seems responsive to reviews, I look forward to a III revision of the HCA-2200 that will fix all my complaints.

Line-Level Preamplifier

Rotel RHA-10

(quick preview by the Editor)

Rotel of America, P.O. Box 8, North Reading, MA 01864-0008. Voice: (800) 370-3741. Fax: (508) 664-4109. RHA-10 Stereo Active Controller, \$1800.00. Tested sample on loan from manufacturer.

Although introduced only recently to the U.S. market, this preamplifier was actually designed earlier than the \$550.00 Rotel RC-980BX reviewed favorably in Issue No. 19. I am told that the entire Rotel high-end line, with model designations that take the form RH(X)-10, was used to establish parameters and lay groundwork for

their more reasonably priced bread-and-butter line, which we have found to yield such excellent performance per dollar.

At more than three times the price and sans phono stage, the RHA-10 had better offer something the cheaper Rotel preamp doesn't. So far I can report that it looks a lot snazzier, appears to be built to a higher quality standard with better parts, and measures even lower in line-stage distortion—very low indeed. Whether it's worth the \$1250 price difference will be determined after a more detailed analysis to be published in the next issue.

—Ed.

Stereo Power Amplifier

Rotel RHB-10

(quick preview by the Editor)

Rotel of America, P.O. Box 8, North Reading, MA 01864-0008. Voice: (800) 370-3741. Fax: (508) 664-4109. RHB-10 stereo power amplifier, \$2700.00. Tested sample on loan from manufacturer.

The same applies here as above: this is the high-priced predecessor and role model, so to speak, of the \$1100.00 Rotel RB-990BX, but a later arrival in the U.S. Since the RB-990BX is a our favorite big amplifier on a value-per-dollar basis, the question is again what you get for 2½ times the price. Better protection, for one thing; more glamorous looks, definitely; better sheet metal in the chassis; better parts here and there (not everywhere); but what about performance? I am not ready to tell you because we ran into some minor technical problems, probably unrelated to the design of the amplifier, that make me question our measurements. I can report the approximate clipping points: 210 watts into 8 ohms, 370 watts into 4 ohms. Our small problems will undoubtedly be solved before long, and a detailed analysis of the unit will be published in the next issue.

I can tell you right now, however, that in the same power category the Bryston 4B NRB, for \$505 less, will be a hard act for the Rotel RHB-10 to follow.

—Ed.

Jitter (continued from page 33)

"Interpolation and Decimation of Digital Signals." *Proceedings of the IEEE* 69 (March 1981): 300-31.

Koch, A., R. Lagadec, and D. Pelloni. "Method and Apparatus for Converting an Input Scanning Sequence into an Output Scanning Sequence." U.S. Patent 4,825,398.

Lagadec, R. "Scanning Frequen-

cy Synchronization Method and Apparatus." U.S. Patent 4,780,892.

Lagadec, R. and H. Kunz. "Process and Apparatus for Translating the Sampling Rate of a Sampling Sequence." U.S. Patent 4,748,578.

McNally, G. W. "Variable-Speed Replay of Digital Audio with Constant Output Sampling Rate." U.S.

Patent 4,716,472.

McNally, G. W., R. Lagadec, and D. P. Pelloni. "Method and Apparatus for Measuring the Time Difference Between Two Sampling Times." U.S. Patent 4,564,918.

Robbins, W. P. *Phase Noise in Signal Sources*. London: Peter Peregrinus Ltd., 1982. •

THE AUDIO CRITIC

Digital Electronics: More CD Players, D/A Processors, Transports, and a First Look at the Sony *MiniDisc* System

By Peter Aczel
Editor and Publisher
&
David A. Rich, Ph.D.
Contributing Technical Editor

Digital technology marches on and manifests some fine examples of progress, but not every step is forward.

This is one of the busiest product categories in audio today, and we have tested more equipment since the last issue than we can squeeze into this one. There will be a spillover in the next issue, plus of course new items just being tested. Among the reviews that should have appeared below but are being postponed until next time are those of the **Cobalt 307** and **Deltec Precision Audio PDM 2** D/A converters (the latter with the TI transport), and of the **Denon DCD-2700** and **Marantz CD-63** CD players.

Outboard D/A Converter **EAD (Enlightened Audio Designs) DSP-9000 Pro** (Reviewed by Peter Aczel)

Enlightened Audio Designs Corp., 300 West Lowe, Fairfield, IA 52556. Voice: (515) 472-4312. Fax: (515) 472-3566. DSP-9000 Pro two-chassis digital processor with remote control, \$5500.00. Tested sample on loan from manufacturer.

In my review of the EAD DSP-7000 Series II and DSP-1000 Series II in the last issue I may have left the impression—or didn't I?—that this equipment leaves little or nothing to be desired and that further improvements would be insignificant. Well, the EAD people obviously don't agree with that because here they are with their "statement" product at almost three times their previous top price. EAD, as I have pointed out before, is a serious, engineering-oriented company, almost entirely devoid of the miasma of high-end gibberish—although they occasionally "hear" things that I and my associates don't—so I have to take this all-out effort seriously. We aren't dealing with a bunch of tweaks here.

ISSUE NO. 21 • SPRING 1994

Conceptually, all three EAD outboard D/A processors are the same, differing only in the elaborateness and refinement of implementation. All three current models use the 20-bit Burr-Brown PCM63P-K, the best multibit DAC chip in the business (probably the best DAC chip in the business, period). All three use EAD's proprietary AccuLinear *I-to-V* converter. The DSP-9000 Pro puts a lot of distance between itself and the other two, however, by (1) having all the various analog and digital power supply circuits on a second chassis; (2) providing eight digital inputs, two of each type: professional AES/EBU XLR, ST-type (AT&T) glass, coaxial, and Toslink; (3) allowing all functions to be remote-controlled with great sophistication; (4) reporting all ongoing electronic activities within the processor on a front-panel display with—count them—12 LEDs and 9 control buttons; (5) incorporating all kinds of minor circuit refinements too numerous to list here.

Unfortunately, no circuit schematics were made available to us (as a matter of company policy, I believe). That's one reason why I am reviewing this unit, not David Rich ("no schematic, no review," quoth he). Worse yet, not even a peek under the cover was possible, and that brings me to an embarrassingly trivial but still very real beef about this otherwise splendiferous equipment. On each chassis, the sheet-metal cover is held in place with 12 butter-soft, painted, Phillips-head machine screws. The paint tends to cause some of the factory-torqued screws to seize. Then, when just a slight extra force is exerted with the screwdriver to remove the screw, metal shavings start to fly and the cross slot is stripped beyond recognition in a single twist. Get me the drill, Igor—but, of course, you can't drill into a \$5500 masterpiece! I am told that this penny-pinching feature of the DSP-9000 Pro was eliminated in later production; in

45

fact, I was sent a small bagful of "expensive" anodized Allen-head machine screws, which are supposed to be standard in currently sold units. That did not get my covers off; one way or the other the problem will be solved and I'll be able to look at the innards of the beast. "For want of a nail...", etc.

If black-box measurements are the yardstick of quality in digital audio and not the hardness of machine screws, then the DSP-9000 Pro is arguably the best there is, bar none. Even better than the other two EAD processors? Very slightly, yes. I ran so many curves, in every possible mode of operation, that it would be quite boring and wasteful of space to discuss every one of them here. The digital filter can be switched between 4x and 8x oversampling; the analog output can be either single-ended or balanced; in each output mode three different default output levels for a full-scale digital input are available—the permutations and combinations are endless. I don't believe in the look-Ma-I-have-an-Audio-Precision type of graph-cluttered review. (For that you go to *Stereophile*, where the zillion graphs are purely cosmetic since their meaning is ignored in the evaluations. My Ma doesn't even know I have an Audio Precision, and I keep my graph printouts in the filing cabinet...)

In the digital domain, I found every measurement to be textbook perfect, meaning full 16-bit resolution of a 16-bit input in all modes, no exceptions. With digital input levels in the 0 dB to -10 dB range, there was a very slight amount of gain-related analog distortion, which diminished to absolutely nothing at -20 dB. All digital-to-analog gear appears to have that small deficiency except, mysteriously, the top-of-the-line Sony CD players. The total absence of high-frequency distortion in the output of the EAD at the -20 dB level also indicated that clock jitter was of no consequence. Among the more spectacular measurement results obtained with the DSP-9000 Pro were the 0 dB gain-linearity error all the way down to -105 dB, stereo channel separation in the 112 dB to 104 dB range regardless of frequency, noise floor with digital zero input in the -140 dB to -106 dB range up to 200 kHz (and below -130 dB at multiples of 60 Hz!)—I could go on, but you get the picture: there is really nothing to report when everything is this good. (One hard-to-measure exception: EAD's long-standing *radiated* RFI problem has not been solved; the unit must be unplugged for clean FM and TV reception.)

It was interesting to see that 8x oversampling yielded the flattest high-frequency response (-0.15 dB at 20 kHz) but 4x oversampling resulted in ever so slightly better low-level linearity. The differences were minute, in any event, but do you know of any other D/A processor that allows you to make that 4x/8x change from your listening chair by remote control? (What a totally nerdy thing to do from your listening chair, when you think about it!) The technologically most advanced feature of the remote is actually the volume control (which is also

the feature most heavily used by those who bypass their preamp). Various buttons permit analog volume steps of 6 dB, controlled by precision resistors, and digital volume steps of 0.2 dB between those large steps. Thus the maximum possible degradation of digital resolution is 1 bit (corresponding to 6 dB), eliminating the single disadvantage of digital volume controls. Pretty neat trick. For absolute-phase sticklers there is also a Phase button on the remote. Now, these buttons here are for regular and decaf... (just kidding, you deadly serious weenies).

Bottom line: should you buy the EAD DSP-9000 Pro? If \$5500 means little or nothing to you and pride of ownership means a lot, and if you need to switch between a large number of digital sources, then by all means go ahead, with my blessing. It's a superb piece of equipment, able to stand up under the most exacting technical scrutiny, unlike most of its high-end competition. Does it sound different from the \$999 DSP-1000 Series II in an ABX comparison? Absolutely not, and I didn't expect it to. Does an audiophile live by sound alone? I don't have to answer that.

Compact Disc Player

Harman Kardon HD7725

(Reviewed by David Rich)

Harman Kardon Incorporated, a Harman International Company, 8380 Balboa Boulevard, Northridge, CA 91325. Voice: (800) 343-9381. Fax: (818) 893-0626. HD7725 compact disc player with remote control, \$849.00. Tested sample on loan from manufacturer.

One thing you can say about Harman Kardon is that they do not make me-too products. The innovation in the HD7725 CD player is their proprietary RLS ("Real-time Linear Smoothing") technology. The RLS circuit performs linear interpolation between adjacent sample points at the output of the DAC. Linear interpolation provides more filtering than is obtainable by simply holding the sampled signal's value for a sampling interval. The calculation of the amount of filtering provided by linear interpolation is relatively simple but requires a little math. Since your Editor believes this would be enthusiastically received by about 17 readers of *The Audio Critic* [because it isn't just "a little" math—Ed.], I refer interested readers to A. Papoulis's textbook *Signal Analysis*, page 141.

The easily understood advantage of linear interpolation over sample-and-hold is that simpler, lower-order analog reconstruction filters can be used. The hard part of taking that route is the design of an analog circuit which will perform the functions of linear interpolation and filtering. In the HD7725, two DACs are used per channel. The data into the second DAC is delayed in a digital memory by one oversampling period relative to the data

THE AUDIO CRITIC

into the first DAC. The output of the undelayed DAC is sent to the CD player's output. Added to this signal is the interpolation signal, which is formed by the following interesting circuit. A signal is generated which represents the voltage difference between the delayed and the undelayed DAC just after a sampling interval. This signal then drives a first-order RC network. When the difference signal steps to a new value, the RC network starts charging. The RC values are chosen so that the exponentially rising signal at the output of the network approximates a linear ramp during the time interval between DAC output samples. Clearly, if the RC network's time constant is not *exactly* right, the generated interpolation signal can overshoot or undershoot the ideal interpolation signal. The complexity of the whole circuit and its potential to misbehave would seem to argue against its general usage and point to other solutions, such as filtering the signal in the analog domain or putting the entire interpolation circuit in the digital domain.

The CD mechanism of the HD7725 uses a number of plastic gears and a small dc motor to articulate the laser pickup assembly. At this price point it is more typical to use direct-drive linear motors, which should be in theory more reliable. (I must hasten to point out, however, that I once had a problem with sticking rails on the linear motor of my Pioneer Elite PD-71, resulting in random skipping. This was easily fixed by cleaning and lubricating the rails, so if you have such a problem don't let a crooked repairman sell you a new laser!) The electronics of the Harman Kardon CD transport mechanism consist of three large-scale integrated circuits, two smaller-scale circuits used to drive the motors, and about a hundred discrete components. All the electronics associated with remote sensing, keyboard decoder, fluorescent display, and microprocessor management are in just one additional VLSI chip.

The power transformer of the HD7725 has four secondaries. The analog supplies are filtered by 2200 μF capacitors on the unregulated supply rails; the digital supplies have larger 4700 μF capacitors. Five voltage regulators are used in this CD player; all are discrete open-loop devices. Zener-diode voltage references are biased from the unregulated supply rails. The pass transistors are a 2-transistor compound device. An additional transistor forms a current limiter for the regulator. Regulated analog supply rails are a relatively low $\pm 12\text{ V}$, probably because only 30 V rms is available on the transformer secondary that powers the analog circuits. At this price point (\$849), I have come to expect a more robust power supply. As for the PC board, it has a top-side ground plane but does not have plated-through holes. The relatively thin sheet metal of the housing is reinforced at the top and bottom of the unit with additional steel plates.

The digital filter chip is the NPC SM5840. No, that isn't an advanced version of the SM5813. It is a cost-reduced version, with fewer than half the taps. As a

result, stopband rejection is 55 dB instead of 110 dB, and the passband ripple is large enough to be observable (see the measurements discussed below). This chip is not what I would expect in an \$849 CD player. The DACs are Burr-Brown PCM61P-K multibit devices—good but not the best. Even so, I find four of them in an \$849 unit to be quite generous. The DACs are enclosed in a shielded metal box; I am not sure what this accomplishes but Krell also does it in the \$3900 Studio. The I/V converters use the internal op-amps in the PCM61P-K DACs. To see high-feedback integrated op-amps used in a Harman Kardon is equivalent to finding a rabbi eating a bacon cheeseburger. I could never get a good answer from the company on why the low-feedback, all-discrete-components approach the company expounds does not apply to I/V converters. The fact that Krell does the same thing in the Studio is not a defense that holds up in my court. I thus sentence Harman Kardon to spend at least a day evaluating the low-feedback Phototronics PA630 current-conveyor chip.

After the I/V converter, it's low feedback and discrete all the way. A 6-transistor complementary G_m cell, similar to the circuit used in the phono stage of the Harman Kardon AP2500 and in the Krell Studio (no cascodes, only resistors to bias the differential pairs), follows the I/V converter of the delayed DAC. It is configured as an inverting amplifier. A passive RC filter follows, and this in turn is connected to a 3-transistor buffer stage identical to the one used in the AP2500 preamp (here Krell uses a complementary open-loop buffer—the Harman Kardon approach is again surprisingly close). Outputs are muted by two bipolar switches, something that Krell would never do; at this price point I would like to see a relay. Two sets of outputs are available on the HD7725: the fixed-level output just discussed and a variable output routed through a motorized volume control. A separate headphone amplifier is connected to the variable output, with an NJM4565 driving the headphones.

As I have already said, realizing the linear interpolation circuit is not trivial. Another open-loop buffer is connected to the G_m cell's output. The buffer output is connected to a 2-resistor summing circuit, which is also connected to the undelayed DAC. The output of the summing network is connected to the RC network. The output of the RC network is connected to the plus input of the G_m cell. As the voltage on the plus input of the G_m cell moves, its output moves, and thus the interpolation signal is added to the CD player's output.

Frequency-response measurements showed some minute ringing, of the order of $\pm 0.025\text{ dB}$ (2.5 millibels), due to the limited number of the taps in the digital filter; otherwise the response was dead flat up to 20 kHz. De-emphasis is done digitally, and no significant error was measured. Channel separation was greater than 100 dB below 4 kHz and was still 92 dB at 16 kHz. No hum

components could be identified in the noise spectrum, a truly rare engineering achievement. Gain linearity error with dither at -90 dB was +0.4 dB in the better channel and a not-so-good +1.2 dB in the worse channel. The latter showed +0.2 dB error even at -70 dB; the better channel was off by only +0.1 dB even at -80 dB. The spectrum of a 997 Hz tone with dither at -90 dB looked very clean, however, in both channels. In the time domain we also saw more ringing on low-level sine waves and on the CBS test CD's monotonicity track than would be expected from a good multibit DAC like the PCM61P-K. The RLS circuit is the likely culprit for these strange effects in both the frequency and time domains.

THD + N for a 997 Hz signal measured at the theoretical limit at signal levels below -80 dB, then strangely rose to 2 dB worse than the theoretical limit at -60 dB, staying there at all levels up to -20 dB, then rising to 8 dB worse than the theoretical limit at a 0 dB signal level. For a -24 dB input signal, the THD + N does not rise with frequency. For a 0 dB input signal above 2 kHz, the THD + N does rise, going to -73 dB at 16 kHz. I do not think the distortion is coming from the analog section, since the AP2500 preamp uses the identical circuit and showed no significant distortion at 2 V rms. Nor is the distortion coming from the K-grade DACs. So that leaves—you guessed it—the RLS circuit as the likely cause.

Since Harman Kardon claims considerable sonic advantages for the RLS technology, we went out of our way to give the HD7725 the opportunity to assert its superiority in listening tests. Three different experienced listeners spent a good many hours ABX-ing the HD7725's own fixed-level analog output against the level-matched output of the \$999 EAD DSP-1000 Series II processor, which was driven from the Harman Kardon's digital output. That way the same CD could be played with and without RLS at exactly the same volume level. The double-blind identification scores were completely random, no different from wild guessing. The two systems could not be distinguished, even though the EAD measures considerably better.

We all like to see audio manufacturers innovate, but the innovation has to improve performance. RLS does not offer improved performance; indeed, it seems to degrade distortion and time-domain performance, even if inaudibly. Because it requires an additional set of DACs, it is expensive to implement. Perhaps this accounts for the presence of a low-end transport, relatively wimpy power supply, and cheap digital filter in an \$849 CD player. The use of an integrated, high-feedback current-to-voltage converter is also surprising, given the company's established design philosophy.

As it stands, then, the HD7725 is not the CD player of choice in this price range. I suggest that Harman Kardon start over, throw out the RLS circuit, and design a CD player with the Burr-Brown PCM63P-K (or similar

PCM1702P-K) and the Phototronics PA630. The PA630 is a true low-feedback current-to-voltage converter and, owing to its very advanced high-speed process technology, should outperform the simple discrete circuits used by Harman Kardon in the HD7725's filter and output stage.

Outboard D/A Converter

Krell Studio

(Reviewed by David Rich)

Krell Digital Inc., 35 Higgins Drive, Milford, CT 06460. Voice: (203) 874-3139. Fax: (203) 878-8373. Studio software-based D/A processor, \$3900.00. Tested sample on loan from manufacturer.

Yes, believe it or not, Krell sent us a review sample of their \$3900 midline D/A converter, the Studio (the top of the line is a \$14,000 unit called the Reference 64). They even provided schematics. The Studio has six inputs: three coax, one Toslink, one AES/EBU, and one AT&T optical. A tape-monitor loop has coax and Toslink outputs. The front panel is filled with LEDs to tell you what you have selected and what the sampling rate is. Both balanced and unbalanced analog outputs are available. The most important feature of the unit is its 16x interpolation (oversampling) filter, made of two Motorola DSP56000 devices and a handful of digital logic chips.

So what's under the hood? First is a significant number of components for routing the digital data lines, interfacing with the front-panel switches, and displaying the results on the LEDs. Digital data are decoded by an encapsulated module identified in the schematic as the bi-phase decoder module. To find out more, I would have to have destructively removed the module's cover, something I am very reluctant to do with expensive equipment on loan. Fortunately, Robert Harley has no such silly inhibitions—see, I can say something nice about Bob—and managed to open the module (in the Reference 64, that is—see his review in the January 1994 issue of *Stereophile*), finding only the Crystal CS8412 receiver chip and a programmable array logic (PAL) for controlling the chip and interfacing it with the DSP chips. No extra PLLs, no proprietary decoding algorithm for data clock recovery, no adaptive PLL loop filters, or anything else special. Harley states that "Krell says this technique [potting the decoder module] improves the processor's sound." I think its purpose is to hide the fact that a state-of-the-art S/PDIF decoder is not used in that *very* expensive Reference 64 unit. I am assuming here that the Studio uses the same potted module.

The decoder module is connected to the digital filter. This is definitely the way to go when designing an audio D/A processor of ultimate quality, since the digital filter algorithm is under the control of the end product's designer, not the chip designer. Another advantage is that

THE AUDIO CRITIC

the algorithm can be updated by changing the firmware PROMs that contain the computer code which controls the DSPs. I was given no information on the algorithm used by Krell in the filter, so let's move on to the DAC.

The DAC is a Burr-Brown PCM63P (K?—the grade is not given on the schematic), placed inside a shielded box. Trim pots are included for adjusting the MSBs of the colinear DACs. Adjusting these pots is very difficult because they affect signals at half of full scale, not around ground. I do not know what method Krell uses to set them. The pedestrian 7805 and 7905 3-terminal IC regulators (what were you expecting, some high-tech discrete regulators?) subregulate the ± 15 V analog supply to ± 5 V for the DACs. The current-to-voltage converter is the SSM-2131 op-amp, which appears to be identical to the PMI OP42G (the only specification differences are a slightly higher offset spec for the SSM-2131 and the addition of a typical THD spec). But wait! Stop!! Hold the phone!!! What's a low-cost, high-feedback op-amp doing in a Krell? What happened to discrete circuits, low feedback, and all that good high-end stuff? Now, don't get me wrong here; the OP42 is an good op-amp for this stage, but it is by no means the lowest-noise, widest-bandwidth, lowest-distortion (see Ben Duncan's article in the December 1993 issue of *Audio Amateur*), and fastest-settling one around. It is not processed with a complementary bipolar process, so its principal attribute is relatively high speed at a low price. (See Issue No. 15, Table 4 for a complete set of specs and prices for this and other ICs used in CD players.) A good price-performance ratio, however, is not exactly what I had in mind as the principal attribute of a component in a \$3900 Krell. I wonder how many of Krell's customers realize that the designer could have used, for example, the Burr-Brown OPA627, which outperforms the SSM-2131 in all respects by more than 2 to 1. The only disadvantage of the OPA627 is that it is three times the cost of the SSM-2131. Note that the \$14,000 Krell Reference 64 does use expensive complementary bipolar op-amps (AD841 and AD846) for its *I/V* converter and deglitch circuit.

The important point here is not the price of the op-amp but the fact that using any op-amp breaks all the supposed rules of "high-end" design. If it is okay to use one op-amp in the signal path, why not make the whole signal path out of op-amps? One would think that once a signal has been "corrupted" by a high-feedback amplifier, no amount of discrete amplifiers downstream could restore its purity. Once the signal has been negatively affected by passing through an on-chip diffused resistor, why should it matter that other resistors in the signal path are of the audiophile-approved variety or that audiophile-grade interconnect cable is used? Once the signal has passed through the class AB (quasi-complementary in the case of the OP42) IC output stage, why should it be important to run the circuits downstream from the chip in

class A? In other words, why do I need to connect the signal from the Studio into the line stage of the \$3700 Krell KRC-2, instead of using an Adcom or Rotel?

In some places Krell does spend money on parts; for example, the de-emphasis circuit for the *I/V* converter is switched by a relay, not a cheap FET switch. After the *I/V* converter comes a passive RC filter. (A first-order filter is all you need with a 16x interpolator.) Then the signal goes to a unity-gain inverter formed with another SSM-2131. This stage is necessary in order to generate the complementary signal required for the balanced output stage. The two signals at the input and output of the inverter are each routed to a simple 8-transistor, discrete, low-feedback output buffer. Now we are back in high-end country. The return-loop feedback resistor is connected to the second gain stage, and the complementary emitter follower runs open loop. The dc offset is canceled with a servo circuit. The power supplies of each buffer are bypassed with 3300 μ F capacitors. The circuit looks remarkably similar to that of the Aragon Mark II D2A (see Issues No. 15 and 16). The principal difference is that the Aragon has the differential pairs biased by a current source to improve the buffers' CMRR and thus reduce distortion. The Krell uses only resistors to bias the differential stages. You may also wish to recall that the \$1600 Aragon Mark II D2A did have a multiple-PLL S/PDIF decoder and a fully discrete low-feedback *I/V* converter, but it did not have balanced outputs and it did not use a programmable filter chip. In the Krell, the signals from the buffers' outputs are routed through a relay, which is open on power-up, and finally are sent to the output jacks.

The power supply of the Studio has separate transformers for the analog and digital sections. On the analog side, separate bridge rectifiers are used for each supply and 4700 μ F of capacitance is on the unfiltered rails. Primary regulation comes in the form of LM7818 and LM7918 integrated regulators. This supply is down-regulated to ± 15 V by MC1468 dual-tracking regulators in conjunction with series pass gates driving each supply rail. The analog supply is shared by both channels.

The mechanical build quality of the Studio is similar to that of the Krell KRC-2 preamplifier. You do not have to know anything about hi-fi to realize that the Studio is an expensive unit. Look inside and you see three separate multilayer PC boards for the power-supply, digital, and analog sections. The boards are interconnected with gas-tight mechanical connectors. The ac line comes directly onto the power supply board. I/O jacks are directly mounted with hardware to the rear panel of the unit (not the main PC board) for added structural integrity. The boards are filled with near-mil-spec components, as you would expect at this price point. What you do not expect to find is that the two PC-board-mounted power transformers and a filter cap overhang the edge of the board. No standoffs secure this area of the PC board to

the chassis as would appear necessary with the overhung components. It does not look very secure; the PC board flexes significantly. I would complain about this if I saw it in a Pioneer receiver. At the Studio's price point it is appalling. Also appalling is the lack of a power switch on a unit that consumes as much power as the Studio does.

Measurements showed that the frequency response of the Krell Studio is down only 0.25 dB at 20 kHz, and the square-wave response showed the typical overshoot and wiggles that result from the truncation of Fourier components above 20 kHz. This indicates that the digital filter is designed to approximate an ideal brick-wall filter. Krell does not play games with the frequency response of the digital filter the way Wadia does. (Of course the Wadia sounds different—it's down 3 dB at 20 kHz!) The Krell also rejects image tones almost completely, unlike the Wadia. Crosstalk stays below -110 dB up to 5 kHz and increases to -98 dB at 20 kHz. A 60 Hz component was identified in the noise spectrum at a level of -108 dB. DAC gain nonlinearity was -0.2 dB at the -80 dB level and -0.5 dB at the -100 dB level. THD + N for an input of -20 dB was -76.5 dB to -77.3 dB (relative to full scale) across the entire signal band, very close to the theoretical limit of -78 dB. The hum components identified above probably account for most of the small difference.

For full-scale (0 dB) signals up to 2 kHz, the THD + N was -93 dB. This is 5 dB short of the theoretical limit of -98 dB. Reducing the signal level to -6 dB did not improve the 5 dB differential. Furthermore, the THD + N did not change when measurements were made in the balanced mode, indicating that the distortion may not be originating in the output stage. It is unlikely that the SSM-2131 is the source of distortion, although the Ben Duncan article I referred to above makes me wonder. My best guess is that the DAC trim pots had not been adjusted properly. Burr-Brown says the adjustments are "in practice... quite complex" and that "near optimum performance can be maintained at all signal levels without using the optional MSB adjust circuitry." The EAD units we have tested did not use the trim pots on the PCM63P-K and they performed better than the Studio in this respect. Full-scale THD + N rose at 4 dB per octave above 2 kHz, reaching a maximum of -83.5 dB at 11 kHz. Again the results were the same for the balanced mode, but in this range there is an improvement in either mode when the level is reduced by 6 dB. It is not clear where the rising high-frequency distortion is coming from; it is even possible that it is a manifestation of high levels of clock jitter.

On the positive side, radiated RFI was exceptionally low in the Studio. That is a truly remarkable engineering accomplishment, given the multiple system clocks and very extensive high-speed digital circuitry in this unit.

In conclusion, the Krell Studio is clearly not the

D/A processor of choice, even for the audiophile who can afford it, because it does not deliver the performance that would be expected for the price. Yes, there is high-level engineering in the Studio, including the industry's first properly performing DSP-based 16x digital interpolation circuit. Yes, the Studio is very well constructed (except for that power-supply board!), with premium parts. But the clock-recovery circuitry is identical to that in units costing thousands less, and the analog stage is actually less advanced than in units costing a small fraction of the price. Indeed, the Sentec DiAna, which uses the Photronics PA630 analog IC, has all its analog stages operating with little or no feedback and costs only \$1150 for all its political correctness. Measured distortion in the Krell Studio was disappointing, especially since it is a high-feedback design. In view of all this, a high-end user might be surprised that it did not sound a little worse than some of the lower-priced competition, but a series of ABX listening tests showed it sounded just like the rest of the group here. So I am keeping my EAD DSP-1000 Series II and feel no loss now that the Krell is gone (except that I have to pull the EAD's power plug to avoid the massive radiated RFI whenever I want to use the radio or TV).

Integrated D/A Converter and Line Amplifier

Monarchy Audio Model 33

(Reviewed by Peter Aczel)

Monarchy Audio, 380 Swift Avenue, Unit 21, South San Francisco, CA 94080. Voice: (415) 873-3055. Fax: (415) 588-0335. Model 33 Dual 20-Bit D/A Converter with Class A Line Amplifier, \$1199.00. Tested sample on loan from manufacturer.

The reader is referred to David Rich's reviews, in Issue No. 19, of the Monarchy Audio Model 22A D/A processor and Model 10 line-level preamp. The Model 33 combines the two at a saving of \$779.00. So far, so good.

We have received no schematics, so I cannot report to what extent, if any, the circuits have been modified. The D/A performance is definitely improved; full-scale THD + N is now -89 dB up to 2 kHz, rising to a maximum of -83 dB at high frequencies, but this includes gain-related analog distortion. The irreducible D/A distortion due to other causes, measured with a -20 dB digital input and normalized to full scale, is -94 dB, still not doing full justice to the top-of-the-line Burr-Brown DAC. The power-supply-related bumps are gone from the noise floor with digital zero input, but the high-frequency noise level is too high (-104 dB at 20 kHz, -79 dB at 200 kHz). Strangest of all, the D/A frequency response is *up* one full dB at 20 kHz. All of the foregoing was measured at D/A out, bypassing the line stage.

The line stage still measures the same as that of the Model 10 (i.e., just fine), and the Model 10's loony-tune source switching system is gone by default, since the

THE AUDIO CRITIC

Model 33 accepts only two external sources, switched by a single toggle switch which can't be up and down at the same time.

With just a little more engineering polish this could become a highly recommendable unit for the money. I know that Monarchy has access to excellent professional engineering; unfortunately they also "hear" things without verifying them with double-blind ABX comparisons.

CD/Videodisc Transport

Monarchy Audio DT-40A

(Reviewed by Peter Aczel)

Monarchy Audio, 380 Swift Avenue, Unit 21, South San Francisco, CA 94080. Voice: (415) 873-3055. Fax: (415) 588-0335. Model DT-40A Audio-Video Laser Player, \$1499.00. Tested sample on loan from manufacturer.

We're in tweako territory here and I won't even blame Monarchy because they're simply giving the tweaks what they ask for, and after all the equipment does work. The tweako belief is that a laser videodisc transport is somehow better for playing CDs than an ordinary CD-only transport. More solid, heavier, more accurate, lower in jitter, or something. I have never been shown scientific evidence of that, nor have I ever met a digital expert with serious credentials who actually believed it, but there you are.

This is a late-model Japanese "combi" player chassis dressed up by Monarchy to do battle as a super audio component. It weighs 50 pounds, comes with special chassis damping, has both S/PDIF and AES/EBU (professional) outputs for connection to a D/A processor, and—let's not forget—will also play videodiscs when plugged into a TV. It even has an S-video output but it doesn't have all the sophisticated control facilities and image-manipulation capabilities of some cheaper, more video-oriented laser decks. It's definitely intended for the audio tweak who wants more than "just a CD player."

I used the DT-40A for quite a few weeks—there's really nothing meaningful audiowise to be measured on such a machine—and I was definitely less happy with it than with the Sony CDP-X707ES that's usually in my system. It sounds the same in a double-blind comparison (what did you imagine?) but it takes forever to reach ready-to-play status on power-up and is slower in access, more cumbersome to operate, and bugger. It has an automatic feature that puts it to sleep in standby mode when not played for a while, and in that mode it has the habit of suddenly sending loud, scary chirps and buzzes through the system without the slightest provocation. I am told that this bug has been fixed, but it sure makes for reduced credibility.

I think Monarchy has some interesting and worthwhile ideas, but this isn't one of them. When it comes to CD transports, I'll have vanilla.

ISSUE NO. 21 • SPRING 1994

Outboard D/A Converter

Sentec DiAna

(Reviewed by David Rich)

Phototronics Co. Regd, P.O. Box 977, Manotick, Ont., Canada K4M 1A8. Voice: (613) 692-2247. Fax: (613) 692-2605. Sentec DiAna Audio D/A Converter (made in Sweden by Antemi), \$1150.00. Tested sample on loan from distributor.

One of the persistent old wives' tales in the high-end community is that negative feedback causes audible distortion even though the circuitry measures very well on the test bench. These ideas were first proposed by Matti Ojala in the 1970s as part of his work on dynamic distortion mechanisms. While his original work was highly plausible, subsequent analysis has shown that dynamic distortion can be prevented even in a high-feedback amplifier if some specific design rules are followed. That should have put the low-feedback argument to bed, but it has not happened yet. If the proponents of low feedback were only the people pushing Wonder Caps, tubes, and \$1000 speaker cables, we could dismiss the case and move on to other things. It is more complicated than that, however. Some excellent engineers still hold to the theory, such as Marty Zanfino of Harman Kardon, Eric Lauchli of Coda, Jason Stoddard of Sumo, my former partner Jon Schleisner of Precision Audio, and Doug Wadsworth of Phototronics.

The last name may be unfamiliar to you, since Phototronics makes electronic components, not audio equipment. One of the former that the company makes is the PA630, an IC specifically designed to form the analog stages of a CD player that uses a current-mode DAC. The current-to-voltage converter stage of the chip uses little or no feedback, and the remaining stages use no feedback at all. Wadsworth, the company's chief engineer, is a highly respected expert in the field of current-mode analog design. He has authored a chapter in the principal book on the subject (*Analogue IC design: the current-mode approach*, edited by C. Toumazou, F. J. Lidgley, and D. G. Haigh), in which he discusses the fundamental block used in the PA630: the integrated current conveyor. Wadsworth has also been published by the IEE, IEEE, and AES in a number of technical papers on the subject. The Sentec DiAna D/A processor under review here uses the PA630.

Whenever I encounter proponents of low-feedback design, I ask them for one of three things: (1) a mathematical analysis showing the deleterious effects of feedback, (2) an electrical test showing the advantages of low feedback, or (3) double-blind listening test results showing that the low-feedback amplifier is audibly superior to (or at least audibly different from) one with higher feedback. So far I have not received any of the above, but I have a lot of IOUs. So, at the moment, if you want to go

53

with the low-feedback crowd you have to do it on faith. I am willing to admit that I used to believe in low feedback myself until I started double-blind listening and could hear no difference. Now, if anybody ever does satisfy one of these IOUs, nobody will be allowed to forget that I hedged a little bit in this review. If nothing ever comes of it, nobody is going to remember the review. But if you want to hedge your own bet, you might consider the Sentec DiAna.

DiAna is the product of two Swedish companies: Sentec (analog engineering, marketing) and Antemi (digital engineering, manufacturing). The project engineer was Svante Österberg at Antemi. The DiAna is enclosed in a little extruded aluminum box about the size of a modem. An external power transformer connects to the wall outlet and supplies 15 V ac to the box. The unit has no power switch; the manufacturer claims that since it draws only 7 watts it can be left warmed up all the time. The little box is crammed with parts on a high-quality double-sided board. Extensive RFI filtering is supplied for both the analog and digital power supplies. Four full-wave rectifiers are used in the power supply. A pair of rectifiers is for the ± 5 V digital supplies, and the other pair is for the ± 12 V analog supplies. Each rectifier is ac-coupled to the transformer. This allows each power supply to float. The digital grounds of the two digital supplies are connected to form the digital groundplane, and the analog supplies are treated similarly. Digital regulators are formed with 7805 and 7905 3-terminal integrated regulators. Analog regulators are open-loop regulators formed with a voltage reference consisting of a zener diode biased by a resistor from the unregulated supply rails. The reference is filtered by an RC filter which then drives the base of a bipolar pass device. The analog supplies are further subregulated to ± 5 V for the DAC power supplies. Separate regulators are used for each DAC (again the 7805 and 7905).

Data for the DiAna can come in through one of two coax inputs or a Toslink. A front-panel switch selects the input. Another switch on the panel is for inverting polarity. After the front-end circuitry selects which input is to be processed, the signal goes into what is currently becoming the standard chip set for high-end DSPs. First the Crystal CS8412 chip decodes the signal and sends it to the NPC SM5813 digital filter. Then the signal goes to the Burr-Brown PCM63P-K DACs before it is routed to the Phototronics PA630.

The Phototronics PA630 has been available since July 1989 (the chip was discussed in Issue No. 15), but DiAna is the first digital audio playback system to use it. I do not understand why the chip has not found greater acceptance among designers committed to low feedback. These designers have instead turned to higher-feedback circuits (see the Harman Kardon HD7725 and Krell Studio reviews in this issue), apparently unaware of the PA630's existence. The PA630 can also be used to make

low-feedback preamplifier line stages. Furthermore it can be used in applications outside audio, where it does show measurably better performance than a voltage-mode op-amp. The chip uses an advanced dielectrically isolated complementary bipolar process.

The first stage of the PA630 is the current conveyor. This is the circuit block which is used for the current-to-voltage conversion. The current conveyor is essentially a current mirror with a unity current mirror ratio. The voltage at the input of the current conveyor is set by a second input of the circuit. This input is set at ground for CD-player applications. The output of the current conveyor leaves the chip to go to a load resistor, which in the simplest case is connected to ground. The output voltage is the DAC current times the value of the resistor. Adding a capacitor in parallel with the resistor forms a first-order lowpass filter, which is used as part of the antialiasing filter. The de-emphasis network, which is switched by a relay, is also connected from the output of the current conveyor to ground. To achieve good noise and distortion performance, the input node of the current conveyor must be close to 0 ohms, the output impedance must be as close to an open circuit as possible, and the current ratio of the current mirror must remain as close to 1:1 as possible over the entire current range. The complete conveyor thus becomes a complex circuit. A discussion of the complete circuit is given in the text cited earlier. In the actual implementation of the DiAna the gain-setting resistor is connected to the current conveyor's input. For a unity current mirror ratio this can be shown to add 6 dB of feedback to the system.

The signal then returns to the chip to be buffered by a 6-transistor open-loop complementary buffer, which is very similar to monolithic buffer chips such as the National LM6321. After that the signal leaves the chip and goes into the passive components of a Sallen-and-Key filter, which generates the remaining two poles of the 3rd-order reconstruction filter. Another 6-transistor buffer on the PA630 is used as the active part of the filter. The output of the buffer is the output of the converter. No muting relay is included, so any signal transients on turn-on are passed directly out of the DiAna. I guess they do not get power interruptions in Sweden.

In our sample, frequency response was essentially dead flat (-0.05 dB at 10 kHz, -0.2 dB at 20 kHz). Crosstalk remained between -108 dB and -106 dB up to 2 kHz, then rose to -90 dB at 20 kHz. The noise spectrum of digital silence showed negligible power-supply bumps of -116 dB and -114 dB at 120 Hz and 240 Hz, respectively.

Gain linearity of the DAC in the less good channel was off by +0.25 dB at a signal level of -80 dB, +0.6 dB at -90 dB, +0.9 dB at -100 dB, and +2 dB at -110 dB. The other channel was off by only -0.2 dB at -90 dB and came back to zero error at -100 dB. Overall, this is a slightly worse performance for a PCM63P-K than we

THE AUDIO CRITIC

have seen in the past but it is basically within the device's specifications. THD + N at an input signal level of -20 dB measured -77 dB across the entire band, just 1 dB higher than the theoretical limit for 16 bits, indicating that the noise level of the PA630 is very low. This is often not the case for current-mode and low-feedback designs. At a -6 dB input signal level a THD + N of -85 dB (the theoretical best is -92 dB) was measured up to 2 kHz, rising to a maximum of -81.5 dB at 10 kHz. For full-scale input signals THD + N was -81 dB up to 2 kHz, rising to -76.5 dB at 10 kHz (the theoretical best being -98 dB). These rather poor high-level THD results are directly due the low feedback. The dynamic distortion evident above 2 kHz cannot, of course, be attributed to feedback; instead, according to Phototronics, the rise in THD at higher frequencies is the result of nonlinear reactance terms associated with the second-order errors of the current mirror. Viewed objectively, the distortion performance the DiAna is not particularly good compared with units we have tested that rely on feedback. None of the known measurement techniques would show that the DiAna was at an advantage over high-feedback designs.

So what can we conclude? The DiAna is a well-built, well-engineered digital decoder. It uses a very high-technology chip to allow it to work with little or no feedback. Unfortunately, in objective laboratory tests it is outperformed by competitive units using higher feedback rates and in blind listening tests it does not appear to be distinguishable from the latter. The EAD DSP-1000 Series II thus remains my choice in competitive digital decoders. For someone who believes that low feedback rates are important and has already invested in a preamplifier and power amplifier designed with low feedback, the DiAna is clearly attractive; to me it makes more sense, for example, to drive a Krell KRC-2 and KSA-200S with a DiAna than with a Krell Studio. But it makes even better sense to take advantage of the virtues of feedback, and so I would rather connect an EAD DSP-1000 Series II into a B&K Sonata Series PRO-10MC and then into a Bryston 4B NRB.

Compact Disc Player

Sony CDP-X707ES

(Reviewed by Peter Aczel)

Sony Electronics, Inc., 1 Sony Drive, Park Ridge, NJ 07656. Voice: (201) 930-1000. Fax: (201) 930-4748. CDP-X707ES compact disc player with remote control, \$2000.00. Tested sample on loan from manufacturer.

This is the supposedly updated successor to the CDP-X779ES I endorsed so enthusiastically in Issue No. 18. I refer the reader to that review for all the details, since the new unit is so similar that I don't even understand why Sony had to change the model number. The heart of the design, the somewhat mysterious CXD2562

pulse D/A converter, is exactly the same. I had the opportunity to have both players on the lab bench side by side; David Rich analyzed the circuit schematics and service manuals of both. Here are all the differences the two of us could find:

Mechanically and cosmetically the two models are identical, except for a seemingly more robust disc drawer in the new model. This is just a small extra touch added to what was already a state-of-the-art transport, with linear motor drive (as in the older CDP-X777ES), CXD2500 DSP chip, and CXD2501 digital servo chip. Tweako high-end transports at higher prices are not as good!

Electrically there appear to be some minor changes in component parts in the new model, plus a new audio board that differs from the old one in only one important respect, the digital filter IC. The new chip, making its debut here as far as I know, is the CXD2567, dubbed "Score" by Sony. It replaces the CXD2560 used on the old audio board. (Interestingly, the service manual does not show this change, so I had to take Sony's word for it, especially since the chip is mounted on the underside of the audio board and is inaccessible without major surgery.) In overall performance the CXD2567 appears to be identical to the CXD1244 (see Issue No. 15). The filter has a 20-bit data path, a 26-bit coefficient word length, and it uses 213 taps. As can be seen from Table 3 in Issue No. 15, this is still a significant step down from the mighty CXD1144 (22-bit data path, 28-bit coefficient word length, 293 taps), giving up 20 dB in stopband attenuation as well as a smidgen in passband ripple. The accumulator output of the CXD2567 is very large at 45 bits. This is truncated to 20 bits with a quantizer block which uses triangular dither—that's the major innovation and the only possible justification of the model change. The CXD2567 and the similar NPC SM5842AP are the first monolithic digital filters to incorporate dither in order to prevent the truncation process from introducing distortion.

In measured performance the two CD players differ by only a fraction of a dB on all Audio Precision tests, which is no more than what the expected production variation would be within a single model. The one exception is the suppression of 60 Hz, 120 Hz, and 180 Hz power-supply spurious in the noise floor of the CD player, which is even better (by 7 to 10 dB) in the new model, although the old one was certainly good enough in that respect. The new digital filter chip does not appear to have made a measurable difference, at least not on a CD-in/line-out basis.

That's it; the old CDP-X779ES and the new CDP-X707ES are otherwise indistinguishable. Consequently this remains the CD player of choice for the well-heeled audiophile who craves theoretical perfection whether or not he can hear the difference. All measurements nudge the theoretical limits of 16-bit digital audio (see Issue No. 18 for the specific numbers). The only quibbles one

could possibly come up with have to do with the analog circuitry following the DAC, and they are minor. Why the slow-settling 5532's at this price instead of, say, AD797's? (Not that the 5532's appear to cause any problems.) Why is the single-ended output more sophisticated than the balanced output? (The former uses a discrete MOSFET output stage and a dc servo, the latter does not.) The answer could be that Sony has altogether different design teams for digital and analog, the digital team being more perfectionistic. Just a hypothesis.

By the way, if it was yet another Sony team that designed the power supply circuits, they did the most incredibly perfectionistic job of all, as David Rich pointed out in a memo to me. The sophistication of the analog and digital power supplies and the extent of regulation are unequaled by much costlier high-end equipment, such as Krell. This should have been mentioned in the original review.

Those who have read my EAD DSP-9000 Pro review above and are into techie overkill regardless of cost will now ask whether the Sony shouldn't be plugged into the EAD for even "better" performance. The answer is yes if you're planning to switch around among a whole slew of other digital program sources, no if you wish to play CDs only. Nothing will play a CD with greater accuracy than the Sony CDP-X707ES.

Second-Generation MiniDisc Recorder **Sony MDS-501**

(Reviewed by Peter Aczel)

Sony Electronics, Inc., 1 Sony Drive, Park Ridge, NJ 07656. Voice: (201) 930-1000. Fax: (201) 930-4748. MDS-501 Mini-Disc Recorder with remote control, \$1000.00. Tested sample on loan from manufacturer.

Originally I was going to review the MDS-101, which was a rather kludgy embodiment of Sony's first-generation MiniDisc technology—a compact home deck that betrayed its car-audio origins. It barely missed being included in the last issue. Then, at the Winter CES, I heard the exegesis of the second generation of MiniDisc products by the brilliant Dr. Roger Lagadec, Sony's technical director in Europe. Shortly thereafter this slick new machine arrived, and as far as I was concerned the MDS-101 was history, especially since the price had not changed.

By now the MiniDisc has been widely exposed and explained; I refer the reader to David Ranada's "Inside MiniDisc" (*Stereo Review*, March 1993), to the late Leonard Feldman's "The Mechanics of Sony's MiniDisc: Beyond the Caddy" (*Audio*, December 1992), to Sony's own widely distributed brochure "*MiniDisc: an overview to the technology behind MiniDisc*"—I see no need to go over the same ground that others have covered so competently. Nor do I wish to repeat here the comments I re-

cently made on digital technology vs. digital politics in the wake of the R-DAT; see the DCC article in Issue No. 20 for that (p. 44).

I tried out a political zinger on Dr. Lagadec at his press briefing, and he handled it candidly and illuminatively. I asked him if Sony would ever have come out with the MD if the R-DAT hadn't run into heavy political opposition. He replied that they probably wouldn't have (!), not in the MD's present form, but that the idea of a wafer-thin, $2\frac{3}{4}$ square, hard-shell, highly efficient, recordable/erasable data-storage medium was too attractive not to be pursued by the Sony technical teams, and therefore some sort of product would have come of it. I was satisfied with that answer.

The fact is that the MD, when you hold it in your hand, is smaller, cuter, cuddlier, more lovable than the DAT cassette, let alone the relatively massive DCC. You *want* it to be the winner, even though in purely sonic terms it isn't. The Sony party line, in all their advertising and PR, is that the MD is not intended to compete against the CD or the DAT—heaven forbid!—but that it is the modern replacement of the dinosaurian analog cassette. Time will tell whether such positioning is viable; right now a recordable MD costs six to eight times as much as a high-quality blank analog cassette—not very tempting to defectors. (I said recordable MD because prerecorded MDs are actually a different medium in the same format, just a tiny CD inside the plastic cartridge.)

The principal audiophile reservation about MD has to do with the 5-to-1 data reduction via the ATRAC (Adaptive TRansform Acoustic Coding) compression algorithm. As our readers know, I and other accountable reviewers (as distinct from out-of-control tweaks) have found the 4-to-1 PASC compression in DCC to be transparent to music, at least the music tried so far. The additional compression with ATRAC poses a problem. The second-generation improvements have made a difference, but on the basis of my very limited double-blind CD vs. MD listening comparisons I am not ready to declare MD transparent. In all fairness to Sony, they do not claim such transparency. I plan to do more testing because the sonic degradation, if any, caused by the current version of ATRAC is quite subtle, and the prerecorded MDs sound pretty much like acceptable, but not great, CDs. For example, if I walked in while the Dvorak cello concerto with Yo-Yo Ma, Lorin Maazel and the Berlin Philharmonic (Sony Classical SM 42 206) was being played, it would never occur to me to say, "Hey, what's that? It's not a CD." It sounds like many middling CDs in my collection (fine performance, though). It should be noted that German researchers using the NMR (Noise/Mask Ratio) technique have found that ATRAC does not completely satisfy the mathematical/psychoacoustical model of a presumably transparent perceptual coder. That research, however, comes from the first-generation era of the system.

THE AUDIO CRITIC

**High-Definition
Thinking in
Small, Furry
Mammals**
or
**The Weasel's Guide to
Maximum Satisfaction**
By Tom Nousaine

Editor's Note: Tom Nousaine is tacitly assuming here—a bit optimistically, or even parochially, I think—that all readers will remember from his last column what Clark Johnsen, the medicine man of Absolute Polarity, had called him—yes, "a weasel"—and that Tom now wears the label as a badge of his audio philosophy. (See also Johnsen's latest protestation anent Nousaine in this issue's "Box 978.")

* * *

The Editor's comments about the usage of *geek* and *geak* in the last issue made me realize that our feel-

ings about audio can obscure a clear view of the best means for rational pursuit of what I call High Definition entertainment. High Definition to me means a maximum "sense" of accuracy, realness, or involvement for a given set of resources. The realization that resources—time and money—are always limited means a High Definition Geak (or HD Weasel for you English majors) needs to pursue a strategy that will maximize expected gains for a given set of financial inputs. We can't afford to waste energy chasing our tails, spitting in the wind, tilting at windmills, or tugging at Superman's cape.

The basic issues can easily be divided into four categories. First, there is little argument from anyone—consumer or pro, golden ear or engineer, scientist or mystic—that loudspeakers, microphones, artistic performance, and recording techniques can radically affect the quality of the listening experience. I call these Givens. Notice that they affect each "end" of an audio system.

Next we have the Inevitables. It doesn't much matter whether you think LPs are better than CDs. The

former are on their way out. So are compact cassettes. CDs and laser discs are here to stay. Data-reduced formats (DCC, MD, and others) are coming. And so are new digitally based video formats. These are subject to availability and only partially subject to personal preference.

There are few arguments contesting that additional processing of signals as they travel through the system alters the way things sound. Equalization, noise reduction, video and surround processing are common examples of Additives. Some, like me, find them useful. Others hate them, but we don't argue about whether they make a difference.

Finally, there aren't enough hours in the day for people to argue about whether switching, gain, and transmission devices degrade or improve sonics. Basically there is debate about whether amplifiers, switchers, converters, cables, line cords, and so forth have special audio qualities other than moving a signal from one point to another or making it bigger. These are the Questionables.

No one disputes that Givens and

As for the MDS-501 itself, it may not be an entirely representative example of the second-generation MD line because it is a 17" wide home deck, whereas most MD products are designed to be portable. I wanted a sample of the MD technology at its most advanced before I looked at the more plebeian versions. An MD Walkman review is in the pipeline.

If I had never seen a high-end CD player or DAT deck, I'd be totally blown away by the MDS-501. What a nifty machine! The sophistication of the microprocessor-controlled status display, the editing facilities, the speed of track access, the look and feel of the controls, including the remote, are all on the order of sci-fi spaceship gear. I'm not kidding. Don't play with this deck in the store because you'll take it home and you probably don't really need it.

As in the case of the DCC, I was not interested in measuring with the Audio Precision just how drastically the perceptual coder alters the signal; that's Sony's psychoacoustic lookout. I was again interested, however, in what is supposed to remain unaltered, i.e., in the accuracy of D/A conversion and in purely analog distortion. To my surprise I found that in these respects the MDS-501 is a match for all but the absolute best CD players, D/A processors, and line-level preamplifiers. At line out, the full-scale THD + N of the delta-sigma DAC at most fre-

quencies is -89 dB, kicking up to -83 dB at 20 kHz. Some of this is gain-related analog distortion; the irreducible D/A distortion due to other causes was found to be -92 dB at all frequencies. Few DACs are better. The gain-linearity error is 0 dB down to the -90 dB level and only 1.6 dB at -100 dB. Highly respectable. The purely analog THD + N (line-in/line-out at full gain, a worst-case setting) is noise-dominated and reaches a minimum of -74 dB (0.02%) at 2 V out, with virtually no dynamic distortion apparent. Could be better, but I've seen a lot worse. The line-in/line-out crosstalk at 2 V out is sensationally low in one channel (in the -113 dB to -90 dB range, depending on frequency) and ordinarily low in the other channel (steadily rising with frequency from -107 dB to -57 dB); this must be due to parts layout. The digital-in/line-out crosstalk ranges from -124 dB to -83 dB, depending on frequency. There are no frequency-response deviations of more than 0.05 dB at any frequency in any mode.

We are in the earliest stages of the perceptual coding era; the plot will surely thicken and various solutions will come and go before we see any permanence. Even though I have some apprehensions about the possible threat to linear PCM technology as the gold standard, for the moment I am not discouraged by the MD solution. A lot of very good engineering went into it. •

Additives affect the sound. It is obvious to me that their sonic impact has to be orders of magnitude greater than those of the Questionables, where there is so much argument (even if you ignore deciding who's right). Debates over the sonic attributes of cables are a laughable tempest in a teapot compared with the questions raised by differences in loudspeakers and recordings.

Therefore, the clever HD Weasel adopts a policy of spending his money and time where they are most likely to have maximum positive effect. His strategy will devote the most energy to selecting better loudspeakers and recordings. He will make informed decisions about formats which may later affect his choices in loudspeakers. He knows amplifiers, preamps, and transmission devices will greatly enhance the usability and style of the system but have minimal sonic impact, and he makes his choices accordingly. He designs systems as a whole and improves them from the outside towards the middle.

For example: The list below shows my perspective on the most appropriate order of resource expenditure in terms of maximum sonic impact for a given expenditure. Of course, I don't always spend my money in exactly the proper order, but I am aware that while maximizing personal satisfaction I might also be suboptimizing sonic performance by ignoring the rules.

But it is a choice...and I can't change reality with my feelings. It doesn't matter what I would like to believe; no one has been able to tell competently designed amplifiers apart with the logos removed. Buying products with my heart and not my head may compromise sound quality.

To maximize sonic impact,

spend money in the following order:

Givens.

1st—Better recordings. You can use your heart here as well. Plus, on an individual basis, they are relatively inexpensive.

2nd—Better loudspeakers. Transducers with flat on-axis response, smoothly controlled directionality, extended bandwidth, and wide dynamic range yield the next-biggest bang for the buck.

3rd—More loudspeakers. Add a subwoofer to extend the bandwidth of your system. Employ surround/center systems to solidify the image, widen the listening area, and improve dynamics. See the 4th step.

Inevitables.

4th—Give your system an image. Video and surround processing is on the way. Don't fight it. The best way to improve the imaging of your system is to literally give it an image. You might argue that a surround processor is really an Additive. Maybe you're right.

Additives.

5th—Test equipment. Want to spend a few grand and learn the truth? Get a Techron TEF, MLSSA, or LMS measurement system. You will find ways to improve the workings of your system by finding out lots of stuff you probably didn't want to know when you started.

6th—Go ahead and get that equalizer. Use it to touch up your main speakers. Important to use the test equipment to adjust. Don't overdo. You can't make a 40 Hz speaker do 20 Hz with an equalizer.

Questionables.

7th—Buy amplifiers with enough power. Buy preamplifiers with enough

inputs and adequate controls. If you want to spend a few extra dollars, make certain you get better build quality with it. Get good remotes. It's far easier to tune your system from the listening position than standing at the equipment rack. Buy CD players, laser disc players, tape recorders and decks, and radios with useful features and good build quality.

Also, buy cables that are long enough, with decent connectors and adequate shielding. Buy stands that position the speakers correctly and look good. Minimize expenditures on accessories. If you're tempted to spend a lot of money on a Questionable, buy some new recordings instead—while you reconsider.

Remember: exotic cables, fancy tubed amplifiers, expensive A/D and D/A converters, and almost anything that exudes weirdness are mostly personal image options. They may improve your self-image or make your system look cool, but they are not likely to improve the sound.

Summary.

Therefore, spending the bulk of your money and time in areas where everybody agrees differences can be heard will improve the probability of maximizing the definition, and hence the long-run enjoyment, of your audio and/or video system for a given dollar expenditure. That's High Definition thinking.

High-Def Weasels take this one step further. If a piece of rusty baling wire rescued from a ditch cannot be distinguished from an expensive speaker cable under blind conditions, the Weasel considers the baling wire *superior* because it frees cable money for more recordings, or concert tickets, or something. That's the trouble with Weasels—you just can't trust them!

Coming:

- ➔ The long-delayed first review of the new Win SM-8 studio monitor speaker and a great deal more on the Velodyne DF-661 low-distortion speaker system.
- ➔ A shootout between the Bag End ELF S18E-C and Velodyne Servo F-1500R subs.
- ➔ All the reviews of CD players and D/A processors squeezed out of this issue (see page 45) plus more digital equipment tests.
- ➔ The beginning of the promised but slow-to-jell survey of FM components.
- ➔ Continued reviews in depth of preamplifiers and power amplifiers.

Hip Boots

Wading through the Mire of Misinformation in the Audio Press

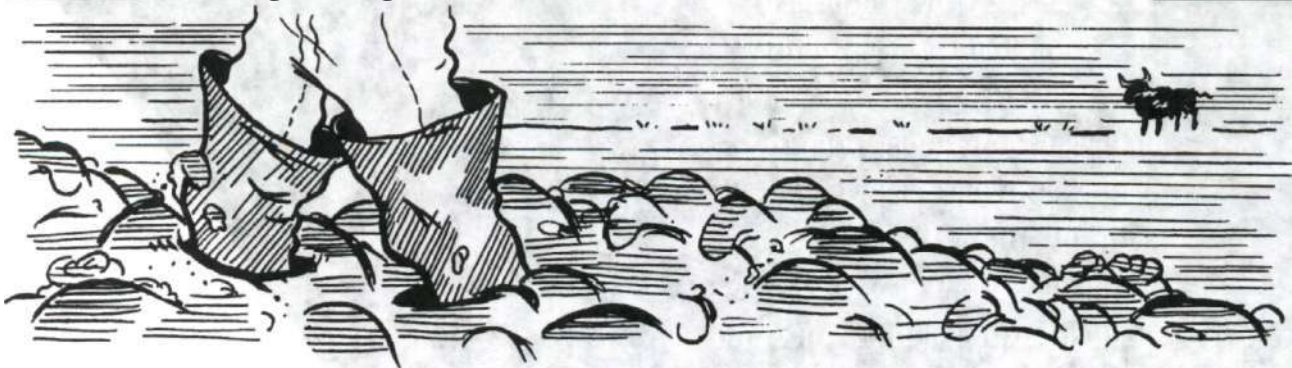

Editor's Note: Many of our readers confess that this is the first page they turn to when they look at a new issue. A few others refuse to understand the purpose of this column. They think we just want to put down our competition. Not so. If *Hustler*, which is definitely not our competition, wrote about the "pace" or "ambience" of a speaker cable, we would castigate them for it as much as we do *Stereophile* and *The Absolute Sound* (and as we did *Business Week* and *Fanfare*, also not our competition, when they printed deleterious misinformation about audio). Naturally, the most frequent offenders are castigated most frequently. By the way, this time I am the sole author of all the items here.

Aftershave.

Ken Nelson, *Stereophile's* chief advertising getter and business booster, has confessed that he was the writer of the "Larry Archibald smiles as he shaves" promotional letter that tickled us so much here (see the first item in "Hip Boots" in Issue No. 20). I have known Ken Nelson for approximately 30 years and have the highest respect for his professional competence and personal integrity. Indeed, I suspect that Ken was the undeserved lightning that struck Larry Archibald and made his magazine the commercial success it is today. I know that Ken is smart enough and honest enough to admit (to himself, privately, when he shaves) that everything David Rich and I have written in this column about *Stereophile* is 100% true. The very fact that he parries our thrust ever so allusively indicates what he must think.

Therefore, in reply to his advertising hyperbole that "*Stereophile* is written to the highest technical and literary standards anywhere in the publishing world," I make my standard offer: Produce three electronics/electroacoustics experts, Ken, with university graduate degrees in engineering or physics who are not commercially linked to your magazine, or to the ultrahigh-end audio manufacturing/retailing/publishing business in general, and who will confirm in writing that your quoted statement regarding *Stereophile's* technical standards is correct—after having examined a number of recent issues to be pointed out by me. If you can do that, I shall admit in print that we have been wrong all along, reprint the statements of your three experts, and mail the issue of *The Audio Critic* containing my admission and the reprints to our entire subscription list as a free extension of each subscription. Fair enough?

60

Harry Pearson goes off the deep end.

This time HP really did it. No, I'm not talking about the latest bit of HP lifestyle gossip. I'm talking about his utterly swinish insinuation in Issue 89 of *The Absolute Sound* that I may have paid Larry Klein—"hired him" is how HP puts it—to comment enthusiastically about *The Audio Critic* in the "Audio Update" column Larry writes for *Electronics Now*. HP actually calls the latter magazine *Popular Photography* (twice!), that's how conscientiously he researches his shots from the hip. The man is out of control and unaccountable. Most of his remarks on the subject are self-parodying, but a few comments from me are in order.

Larry Klein and I have known each other for well over 20 years, going all the way back to his tenure at *Stereo Review* as technical editor; we have nearly always agreed on audio matters, so I don't have to "hire" him to editorialize to the effect that mine is "a thinking audiophile's magazine" and that HP's is "a witches' brew of pseudoscience and unabashed subjectivism...influenced... by price, fads, technical ignorance, and unfettered egos." That's what Larry thinks free of charge, that's what he has always thought, and he would have to be totally insincere to write anything else. HP turns around and calls *him* "ignorant and wrong" on the subject; this is like, say, David Koresh calling Pierre Teilhard de Chardin ignorant of theology. (It was HP himself who made me turn to theology for my example; he writes that "born-again audio fundamentalists now rule the roost" at *The Audio Critic*. Apparently $2 + 2 = 4$ is fundamentalist in HP's view and $2 + 2 = 5$ is enlightened and liberal. Anyway, HP has no technical credentials and Larry Klein does.)

THE AUDIO CRITIC

The funniest part of HP's tantrum is his assertion that both *Stereophile* and *The Absolute Sound* "are dramatically better in technical accuracy and in solid judgments than they once were." Isn't that delightful? Exactly when did you stop being incompetent, Harry? When did you stop beating your... uh... wife?

A Carver ribbon by any other name...

Remember how much *Stereophile* disliked Bob Carver's "Amazing Loudspeaker"? This goes back to 1990; they actually managed to wreck the sales of the speaker for quite a while. (See also the sidebar I inserted in Issue No. 16, page 9, on the subsequent lawsuit.)

Now, in *Stereophile's* report on the 1993 Summer CES (in their August 1993 issue) Contributing Editor Robert Deutsch, one of their leading tweaks, goes gaga over the \$55,000 Genesis I loudspeaker by Arnie Nudell and Paul McGowan. "How did it sound? Absolutely effortless, with far better coherence than I would have thought, given the multiplicity of drivers." In a footnote, RD adds: "Arnie Nudell says that the resemblance to the IRS is in form only. He says the drivers and other aspects of design are quite different." They sure are. Take a look at the picture of the Genesis I on the following page, all you golden-eared *Stereophile* gurus. See that five-foot ribbon smack in the middle? You know what that is? It's the ribbon from the Carver "Amazing," amigos. Supplied to Genesis Technologies by Carver Corporation—as is, no frills, totally unmodified! Are your faces red?

Logical conclusion: When a novel transducer is part of a speaker system introduced at \$1576 the pair, it is baaaad. When exactly the same transducer is part of a \$55,000 tweako rip-off, it is goood. That's credibility, High End style.

And now, the obligatory Harley Howler.

No "Hip Boots" column would be complete without a technical foot-in-mouth item from the bounteous pen of Robert Harley, patron saint of the electronically semieducated. In the August 1993 issue of *Stereophile* (yes, the same issue as I cited above—no need to go to another one to find more blunders), he reviews the \$6000-plus Genesis III five-way speaker system (the one without Bob Carver technology in it) and makes the following fascinating statement: "The crossover slopes vary between second-order (12dB/octave) and third-order (18dB/octave), with increments in between."

He sent me scurrying to all the standard texts on analog filter theory, where I was hoping to learn more about filters of the 2.1st order (maybe 13 dB per octave?), the 2.2nd order (14 dB per octave?), the 2.3rd order (15 dB?), and so forth. To my dismay, I found that such "incremental" orders do not exist! If you add another pole to a lumped-parameter second-order filter—just a teensy-weensy pole, Bob—you jump straight to third-order. Son of a gun! The laws of physics are so frustrating. **ISSUE NO. 21 • SPRING 1994**

ingly unforgiving, aren't they?

Unfortunately, my altruistic appeal in the last issue for contributions to the SHEESH (Send Harley to E.E. School in a Hurry) Fund fell on deaf ears out there in golden-ear country. Only the irrepressible Joe Cierniak (Editor/Publisher of *Sound Off* in APO land) sent in \$10 to be added on top of my pledged \$50, and that was it. As I wrote to Joe when I regretfully returned his check, \$60 isn't enough for Bob's supply of nerdy plastic pocket protectors for four years, let alone E.E. school tuition. There is no charity left in the audio world...

(Not *all* misinformation from Harley is due to lack of knowledge, though. Some of it is just dirty politics. In the March 1994 issue he rhapsodizes that the new Adcom GDA-600 is the only D/A converter under \$1500 to use the 20-bit Burr-Brown PCM63 DAC chip. He conveniently forgets—because EAD is on *Stereophile's* baaaad list—that 11 months earlier he himself reported the debut of the EAD DSP-1000, a \$999 unit that uses the PCM63, in the K grade as against the lower J grade in the Adcom.)

Skull and crossbones on the crossover.

Speaking of Joe Cierniak, it was he who called my attention to this one. Aaron M. Shatzman, archly listed on the masthead of *The Absolute Sound* as Philosopher-in-Residence, wrote a review of the Paragon Acoustics "Jubilee" speaker (yet another small two-way system with big claims, made in Minnesota) in their Issue 92. The review is the usual soundstage-obsessed subjectivistic gush fest, but I wouldn't bring it up for just that.

In a separate little box captioned "Speaker Specifications," the resident philosopher lists crossover slopes of "12,000 volts/octave." Holy Moses, Aaron, that's dangerous! The unit couldn't possibly be UL listed under the circumstances but it should at least have a highly visible death's-head warning label on it, for heaven's sake. Please be careful! Electrocutation is such an undignified and historically unsuitable demise for a philosopher. Hemlock, okay, or even crucifixion, perhaps an *auto-da-fé*—but 12,000 volts...

Epilogue, on a theme by Larry Archibald.

In the January 1994 issue of his magazine, Larry Archibald writes: "...I believe that *Stereophile* offers the most well researched and authoritative reviews available, and that other magazines are, well, basically unnecessary."

If you will accept a bouquet, Larry, from the most unnecessarily critical and factual of the unnecessaries (as you must see us), I consider that quotation to be an immortal classic. I rank it with Herbert Hoover's gem announcing prosperity to be just around the corner, with George Bush's "read my lips" pearl, and with Hermann Göring's declaration that the Allies will never bomb Germany or his name is Schultz (or was it Meyer?). I think the best-educated members of the audio community—and you know who they are—will share my sentiment. •

Recorded Music

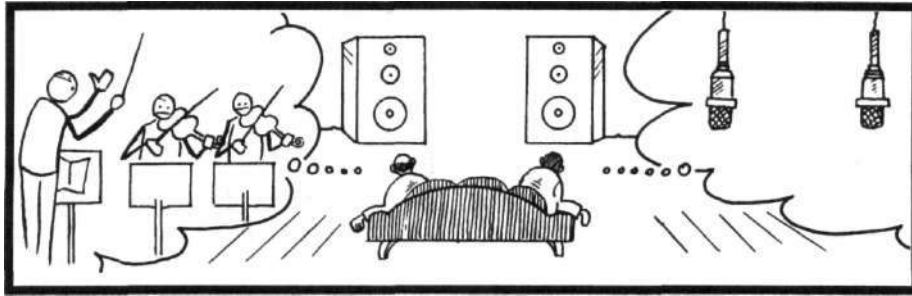

Editor's Note: My massive backlog of CDs to be capsule-reviewed (as in Issue No. 19) had to yield once again to David Ranada's more interesting and equally opportune reviews, but be prepared for a major catch-up sequence in the next issue (No. 22). Meanwhile I'm appending just a few can't-wait-to-tell-you items of my own to the end of Davids column. Don't confuse my opinions with his!

A Miscellany of CDs and Musical Videodiscs

By David Ranada
Contributing Editor at Large

Broadway Musical

Richard Rodgers and Oscar Hammerstein: *Opening Night, The Complete Overtures.* Hollywood Bowl Symphony Orchestra, John Mauceri, conductor. *Philips D 100190.*

Leonard Bernstein: *On the Town.* London Symphony Orchestra, Michael Tilson-Thomas, conductor. *Deutsche Grammophon 437 516-2.*

No musical idiom needs rescuing from the depredations of recording producers and engineers more than the Broadway musical (though big-band jazz comes in a close second). Original-cast recordings of Broadway material only rarely produce the sonic effect of a live pit orchestra in a real Broadway theater. All of these buildings are within a 10-minute walk from where I work, and I've attended performances in a great many of them (probably all those still suitable for musicals). None of them is as large or reverberant as the typical original-cast album will have you believe. The sound is instead hard-hitting, vivid, direct, rather dry, and not very rich.

Not that you can tell from either of these CDs. Mauceri's recording of Rodgers overtures is severely compressed and has a reverb characteristic seemingly tacked on from another space altogether. The reverb machine should have been turned off. The percussion in particular lacks bite and impact. But the sound is rich and luxurious—and altogether inaccurate, unrealistic, and unauthentic. Unfortunately, due to the corrupting influence of recordings like this one, live Broadway productions now are overmiked, overamplified, and disgustingly reverbed to sound like—recordings!

Musically, I liked the performances, though an hour of Richard Rodgers's instrumental music, even in its original orchestrations (none by him), is a bit too much of a good thing—I wanted to hear some singing. But if this is what you want, this is the only game in town.

There's singing in abundance in Tilson-Thomas's rendition of Bernstein's 1945 *On the Town*, which receives its most complete recording to date with Deutsche Grammophon production, one recorded using

DG's proprietary "4D" technique, about which I will have more to say in a future issue. Suffice it to say that despite the use of "21-bit" A/D converters, the recording's waveform is clipped during many loud portions of the music. It's not audible per se and it occurs at very slightly below CD-maximum level, indicating either that the signal passed through a digital console or other processor that clips below unity gain, or that the signal was clipped earlier in the chain (perhaps at the mike preamp or initial A/D conversion). In any case, sloppy production is indicated—there's no good reason for any digital recording ostensibly made with resolution greater than 18 bits ever to clip. (A conspiracy theorist will say that it is deliberately clipped in order to obtain thereby some degree of compression, to produce a "louder," more impactful disc, as is typically done with FM radio signals.) While we're speaking of slop, there's also some low-level grungy electronic-sounding noise in the right channel at the end of Track 4.

The orchestra here—the London Symphony—is quite a bit larger than

THE AUDIO CRITIC

your typical pit band. It was also recorded live in a hall (London's Barbican Center) that I recall not being as reverberant as it sounds on this disc. The dead giveaway is the obvious artificial reverb tacked onto the end of Tracks 2 and 13. This recording is, like the Rodgers disc, a multi-miked multiple-mono extravaganza.

I liked the performance here too, though Tilson-Thomas's conducting often sounds manic compared to the composer's own excellent 1960 recording (nicely remastered—and with a very theaterlike ambience—on Sony SM3K 47154). The overwrought feeling is abetted by the size of the performing forces: you can't move that many people that quickly without making it sound frantic. The singing is more operatic than in Bernstein's recording (except for the always-yelling Tyne Daly) but still within the bounds of Broadway style. The disc includes, in their proper sequence, all the extended dance episodes and several vocal numbers never before recorded. Get both: Tilson-Thomas for singing and completeness, Bernstein for interpretive and sonic authenticity.

Opera

"The Golden Ring: The Making of Solti's 'Ring'." A BBC film directed by Humphrey Burton. **London** videodisc 440 071 235-1.

Anybody with an interest in classical music recording techniques and in the role of the recording producer must see this program, which is also available on VHS tape (440 071 235-2). The film, by Humphrey Burton, is of the 1964 recording sessions for Georg Solti's London/Decca performance of Wagner's *Die Götterdämmerung* (London 414 115-2). Unlike more recent recording-session programs (which are really promo videos that have a suspicious habit of appearing on PBS at the time the associated CD is released), this one has a point of view: to explore the relationship of a recording's creators, especially the ones on the technical side—"high priests of flawlessness," Burton calls them—to the work being recorded.

We see the recording producer,

the late, great John Culshaw, in his element: deciding orchestral balances, which takes to use, where the takes need to stop and start to ease the task of splicing, what the musical deficiencies of the actual performance are. We hear him agonizing over "what the composer wanted" and how to "do the best by Wagner." In short, we watch him doing what a recording producer should always do.

Students of recording techniques will enjoy seeing the massive amounts of technical nitty-gritty exposed to the camera: mike placement (including the famed Decca "tree"), the mikes (mostly Neumann, as far as I could tell), the tape recorders (½-inch open reel), the tube electronics, how instruments like the harps are moved from their customary placement instead of being given spotlight mikes, and how the singers are scrupulously directed by a "stereo man" to chessboard-like numbered squares on the stage to achieve specific—then revolutionary—stereo effects. We are told by an engineer that 12 orchestra microphones are "sufficient" for this massive work; twice that number, and more, is now common. There are also 3 stage mikes for the singers and 5 mikes for specific offstage effects, such as the stierhorns called for by Wagner's score.

Careful viewers will notice that the stierhorn pickup is mono and sounds artificially panned-in during the finished production (one of the recording's few technical miscalculations). Wagnerites will undoubtedly note how the actual last sung words of the entire *Ring* cycle (Hagen's "*Zurück vom Ring!*") **are not performed** during the take of the "immolation" scene we see being recorded. Perhaps it, like the sound of the collapsing hall of the Gibichungs, was dubbed in later. Musicians will enjoy actually seeing a bass trumpet in action, the noble-sounding "Wagner" tubas, and other brass instruments with the uncommon valve mechanisms used by the Vienna Philharmonic.

You'll also see some strange singer behavior, like the way they lunge toward the microphone at the end of some phrases (perhaps to emphasize a weak note) or slightly back

off on high or loud notes (perhaps to prevent overload somewhere in the chain). It's interesting to go back to the finished recording to see how these actions have affected the sound. At the very least, the backing-off motion increases the vocalist's "leakage" into the orchestra mikes.

The rare person who likes to make measurements of recordings will be fascinated to find that those musical segments of the finished recording that in the movie obviously originated from video still carry the near-ultrasonic horizontal scan frequency that leaks out of video cameras and monitors and is easily picked up by microphones. This can be easily seen with an FFT-based spectrum analysis, which shows a distinct spectral component between 15.75 kHz and 15.78 kHz about 80 to 90 dB below full level during those segments. Even more fascinating is that this spectral (and spect[e]ral) component is slightly higher than the standard European horizontal scan frequency (which has long been 15.625 kHz). This possibly indicates that the CD's analog master tapes were running slightly faster (by about 17/100 of a musical semitone) during the mastering process than they did during the sessions. Rosetta stone indeed!

Other technical notes: The sound is very good mono, the picture black-and-white with variable quality depending on whether the shots are from film or video. Although the narration is in English, as are most of the on-camera comments, it is a boon to know German, the language Solti usually uses with the orchestra. The camerawork is good—meaning conservative—with few zooms and no dental-exam ultraclose-ups of spit-spewing and sweating vocalists. There are a few misdirected shots in some of the extended musical portions (such as Siegfried's funeral procession), but they serve only to lend a video-vérité feel to the proceedings. Again, a must-see.

Wolfgang Amadeus Mozart: Don Giovanni. *The London Classical Players, Roger Norrington, conductor.* **EMI** CDCC754859 2.

Don Giovanni, the greatest of

Mozart's operas, receives here its most "authentic" recording to date, in musicological rectitude a veritable doctoral dissertation compared with the term-paper quality of the only other original-instrument recording (Östman's on L'Oiseau Lyre 425 943-2) and with the high-school essay that was Richard Bonyng's earnest early attempt at correct performance practice (London/Decca, not yet on CD).

The authenticity in this case extends to the ambience (a rather dry-sounding Abbey Road Studio 1), the employment of unwritten, but stylistically mandatory, appoggiaturas by the singers, and a true 18th-century operatic seating arrangement for the orchestra (and not just a version of the 19th-century/divided-violins layout). A seating diagram is helpfully given in the accompanying booklet, which also describes the simple CD-player programming to use to make the discs play either the original (Prague) version or Mozart's own revised (Vienna) version. Music is provided for both.

Most surprising to most listeners will again be Norrington's tempos, which are usually—but not always—faster than normal. The most notable exception is the so-called Champagne Aria ("*Finch'han dal vino*," which mentions only wine). [*Champagne is a wine but it did not exist in Don Juan's early-17th-century Seville. Amontillado Aria would probably be more appropriate.*—Ed.] For once it is taken at a tempo that doesn't force the singer to bark out his notes and gains thereby an extra dimension of snarling lasciviousness.

Otherwise, the drama sweeps along at a theatrical—not "operatic"—pace, with possibly too few moments of repose. There certainly is little very soft singing, even when it might be appropriate dramatically and sanctioned by the score. While vocally there is no weak cast member, characterization during the arias and ensembles is shortchanged by all the singers. A little more personality from them would have helped integrate these pieces more fully into the rapidly moving recitatives.

Whatever one may think of these points, there can be little disagree-

ment that Norrington is extraordinarily successful at choosing tempos and manipulating dynamic levels during the condemnation scene, the most hair-raising music of the entire 18th century. The only problem here is the sound, which for once fails to deliver: the chorus of demons sounds like panned-in mono and is not well integrated into the sonic picture (maybe because they're supposed to sound "from below"), and there is a noticeable lack of bass here. And I do think that the last scene (the post-mortem ensemble) follows on too quickly. Not even the quick-acting stage machinery of a Baroque theater could have changed scenery so rapidly, nor could the singers get onstage so fast.

These points are minor. Because of the opera's status as a cultural icon and the overall quality of the performance, this recording is required listening for all Mozart lovers. It will be a cleansing earwash to those brought up on a "traditional" *Don Giovanni*.

Orchestral

Felix Mendelssohn: *Symphony No. 3 in A Minor, Op. 56 ("Scottish"); Symphony No. 4 in A Major, Op. 90 ("Italian"). The Chamber Orchestra of Europe, Nikolaus Harnoncourt, conductor. Teldec 9031-72308-2.*

This 1992 Harnoncourt disc again features the iconoclastic conductor leading The Chamber Orchestra of Europe. The ensemble uses modern instruments but produces a very unmodern sound. The strings are lean and sinewy rather than lush and "romantic," a consequence of vibratoless, and probably gut-stringed, playing. The woodwinds are also more prominent than usual, as can be heard at the very opening of the "Scottish." Harnoncourt has throughout replaced traditional romantic soupiness with meticulous observation of Mendelssohn's specific dynamic inflections (such as swells and various types of accents).

But do not think of these performances as attempts at a historical reconstruction of a mid-Romantic orchestra. At the very least, the modern string seating is demonstrably incor-

rect for Mendelssohn (Norrington on EMI 7 54000 2 is more authentic in this and many other areas). These performances are instead typical idiosyncratic Harnoncourt, who is turning into sort of a modern-day Mengelberg replete with arbitrary and bizarre tempo changes. Cases in point are his distinct slowdown in the first movement of the "Scottish" at the final subject of the exposition ([1] 5:48, less marked at 8:52), and his near cessation of the pulse at the end of the exposition ([1] 6:30) before he takes the repeat. Neither of these Wagnerian "nuances" are specified in the score; Mendelssohn would have been horrified. Harnoncourt has allowed a few moments of ugly playing to stand as well, like the screeching entrance of the violins in the fourth movement ([4] 0:03). But, also like Mengelberg, he can produce some wonderful effects, like the unusually tense introduction of the "Scottish" and the glorious cello line during that symphony's first-movement coda ([1] 12:03).

The sound quality for the "Italian" seems brighter than that for the "Scottish," a difference suiting the two works' contrasting characters. However, Harnoncourt's sometimes exaggerated dynamic inflections of the melodic line tend to lose the last notes of phrases. And despite the clearer sound quality of the "Italian," the inner lines are often obscured, even on headphones. I also found the second movement a bit too slow and the finale rather lackluster, even though Harnoncourt's attention to Mendelssohn's dynamics shifts the musical emphases to unusual places. On the whole, this release is a Harnoncourt-style disappointment: "alternative" interpretations worthy of hearing if not treasuring.

Joseph Haydn: *Paris Symphonies (Nos. 82-87). Sinfonietta de Montreal, Charles Dutoit, conductor. London 436 739-2.*

What a difference a year makes! The first disc of this two-disc set, containing Nos. 82-84, was recorded in Montreal's St. Eustache in May of 1990. A year later, the remaining symphonies were recorded in the same church, with the same producer and engineer, but with a totally dif-

THE AUDIO CRITIC

ferent musical/sonic effect.

The earlier sessions suffer from being recorded at medium distance in what is obviously a very reverberant acoustic that has been used with rather consistent success for Dutoit's London recordings with the larger Orchestre symphonique de Montréal. While the reverb promotes a certain lushness of string tone, it also tends to obscure many details, such as the woodwinds, and to smooth out the nuances of phrasing that are essential for Classical-period music. Large contrasts in dynamics are preserved, smaller ones—like the many sforzandi ("forced," heavily emphasized notes) sprinkled throughout these scores—are not. There's also a slight bass heaviness.

These effects have affected Dutoit's interpretations, which on the first disc are underarticulated and slightly slack. The best performance on the first disc is of No. 84, which features some marvelous woodwind solos in the second movement and, for a change, some verve in the minuet.

Disc 2 is a different story: the sonic distance to the orchestra has been reduced and the musical lines have gained thereby in clarity and vividness. The orchestra sounds more alert to Dutoit's—and Haydn's—dynamic nuances. Even the tempos seem more spirited. No. 87 in particular is distinguished by its woodwind solos, even though the sound is now close enough so that you can hear Dutoit's grunts in the first movement. This second disc makes the entire set of these marvelous pieces worth considering.

Miscellaneous performance notes: Modern instruments are used in the modern string-seating plan (all violins left, cellos and violas right). Only the first half (the exposition) of each first movement is repeated, although Haydn has indicated that the second half (the development and recapitulation) of those movements should be repeated as well (except for No. 86). The same goes for those symphonies whose last movements also have a second-half repeat (i.e., all except for Nos. 85 and 86). I know of no two-disc sets of these symphonies that take these rarely observed repeats. If they were all taken,

the playing-time limits of the CD format would be exceeded. There's a tentative-sounding restart after a grand pause in No. 87's first movement ([9] 4:40) and, finally, Dutoit or his tape editors missed the fermata (a hold) during the pause separating the exposition from the development in the last movement ([12] 1:19 and 2:29). Haydn intended this and similar pauses to desynchronize the listener's internal metronome, a trick he liked to pull.

Hector Berlioz: *Symphonie fantastique*. Orchestre révolutionnaire et romantique, John Eliot Gardiner, conductor. Philips videodisc 440 070 254-1

Hector Berlioz: *Symphonie fantastique*; *Overture to Le Corsaire*; *Overture to Le Carnaval romain*; "Danse des sylphes" and "Marche hongroise" (from *La Damnation de Faust*). L'Orchestre de la Suisse Romande, Ernest Ansermet, conductor. London 433 713-2.

The Philips live-performance video fascinates mainly by its depiction of a reconstruction of an early-19th-century orchestra playing in the very hall where this groundbreaking work had its first performances (the old hall at the Paris Conservatoire). Talk about authentic ambience! Only the 1830 costumes are lacking. But that would have prevented the video director (Barrie Gavin) from featuring, as he apparently does, his favorite sleeveless-dress bass player. (One does get tired of seeing the same faces, many of them not very interesting, over and over again, as if the cameras were at locations with restricted views.) There are a few shots of the wrong instruments at the wrong time, and the harps appear out of nowhere for the second movement. Gardiner uses six of them, amply fulfilling the composer's requirement of "at least two" per part. It makes a substantial difference compared with the paltry pair you get in most performances.

By far the most important directorial fault is the lack of early "establishing" shots of the orchestra's overall placement within the auditorium, and of the size and shape of the auditorium. Although one could figure it out from the short reverb time, especially in the bass, the

smallness of the hall doesn't become visually apparent until the final credits are rolling, when the cameras swing around to show the audience. The video *does* show a Berliozian orchestral layout, which itself is as fascinating as the use of a serpent-shaped ophicleide in the last two movements and of an *angled-tube cor anglais* (usually translated into "English" horn) in the third. The visual direction of the final pages of the work is very well handled, too.

The size of the hall is an important acoustic factor in the success of Gardiner's performance, which takes tempos very close to Berlioz's metronome markings and in which, thanks to the use of period instruments, Berlioz's written-in orchestral balances are inherently produced. The "eagle-eared" will also note with pleasure how easily the old wind instruments seem to perform Berlioz's spooky portamentos (pitch-to-pitch glides) shortly after the beginning of the last movement. Nice, portentous, offstage bells in the finale.

Philips also has a CD version of this performance (434 402-2). It uses different takes—it can't be synchronized with the videodisc—and there's no audience applause at the end. The sound and performance quality remain the basically unaltered.

As an example of how this work used to be played, there are few versions better than the newly reissued Ansermet performance with its modern instruments, modern seating, two harps, and post-Romantic conducting. You get to hear the modern French woodwinds and their deliciously saxlike bassoons, as well as some unusual-sounding bells custom-made for this recording's 5th movement. The sound—discreetly multi-miked—is excellent for its time (1967), as it is in the filler works recorded in 1964. You can even hear a vehicle outside the hall at [3] 0:30-0:40. Recommended as a midpriced second performance.

Gustav Mahler: *Symphony No. 5*. Dallas Symphony Orchestra, Andrew Litton, conductor. Dorian DOR-90193.

Andrew Litton's "interpretation" of this work—I use the word only for convenience—is here undone by the

recording quality, which is inferior to that of most of the Mahler Fifts released over the last, say, 15 years. Even some recent bargain-basement readings of the piece have served the music better. The principal fault is a lack of "heft" to the sound—it is recorded at a far-too-distant perspective. There's low end in abundance, but no body to the strings, no presence to the woodwinds, and no sparkle to the percussion. All you seem to hear are laser-beam trumpets piercing through the echoey haze. Turning the volume some 10 dB higher than where you would normally have it helps, but not much. I can only hope the acclaimed McDermott Hall where this was recorded doesn't actually sound this bad in person.

[My observation has been that Craig Dory usually gets it right the first time in a new recording venue, as he did in this hall with the Stravinsky *Sacre*, and then becomes bored or restless and starts experimenting with more and more ambience. Even that first recording was miked about as distantly as you would ever want, and now he has gone too far.—Ed.]

Young conductor Litton doesn't yet seem to have a total grasp of the Mahlerian idiom. He almost brings the middle of the third movement (a scherzo) to a dead stop, and there is no underlying rhythmic pulse (slow as it could be) to the fourth-movement *Adagietto*, which also features some steely-sounding strings. Among the nuances of tempo that he simply gets wrong is the detectable speedup following measure 338 in the last movement ([5] 6:19), in direct contradiction to the composer's explicit instruction not to hurry (*nicht eilen*), a sin I consider quite serious. But by this point it hardly mattered, since the recording quality lost me at the opening of the first movement. Although this is billed as a live recording, the audience is very quiet until the applause at the end. Maybe they were all asleep.

Ralph Vaughan Williams: *Symphony No. 7 ("Sinfonia antartica"); Fantasia on a Theme by Thomas Tallis. Indianapolis Symphony Orchestra, Raymond Leppard, conductor. Koss Classics KC-2214.*

Following the dubious lead of

André Previn's RCA/BMG recording of the *Antartica* (the composer's spelling), in which Sir Ralph Richardson read the motto-epigrams with which the composer prefaced each movement in the score, this recording uses passages from Captain Robert Scott's Antarctic journals and inserts them *into* the music. (In the published score, the texts actually all appear on a single page *before* the music, implying that they are best used in mood-setting program notes or only as interpretive guides to the performers.) The narrated Scott texts (as well as a contribution from Cardinal Newman, "Lead, kindly light," that appears out of nowhere), while appropriate for the general mood of the piece, always interrupt the musical argument, ruining any coherence the performance may have had. This is particularly noticeable when the music is allowed to come to a complete stop, without even a held background chord. The *Antartica* is not a suite of film music, although some of its themes derive from the composer's score to the 1948 docudrama *Scott of the Antarctic*. It is a *symphony*. It is also not *Peter and the Wolf*, nor *Tubby the Tuba*, two works that unfortunately sprang immediately to mind when listening to this recording. I'm amazed that the whole misguided venture was the conductor's idea!

Too bad, because the sound quality (excluding the lack of lower frequencies in the dubbed-in narration) is very good and quite probably the best this piece has ever received. The occasional huge outbursts come off particularly well. I hope that Koss Classics saves what might actually be an excellent performance by editing out the narrator's contributions altogether. They can then also help the composer by performing a slow electronic fade-to-zero at the end of the work where Vaughan-Williams wrote a decrescendo to *niente*. As it stands, you can still hear the performers actually stop.

The famous *Fantasia* receives no extramusical accretions, though it would have been thoughtful for Koss to have had the choir used during the symphony perform the original Tallis theme as a preface. But here the concert-hall recording quality is less suit-

ed to the music, which was written for Gloucester cathedral. The work divides a string orchestra into three sections: a large body of strings, a string quartet drawn from that body, and a small orchestra meant to be spatially separated from the other two sections. Here that separation takes the form only of an increased right-channel presence with no additional distancing via ambience. The whole ensemble is a bit too closely recorded for my taste (you can hear somebody's almost asthmatic breathing at [6] 6:54-7:03), though this does suit Leppard's passionate, but unrelaxed and nonmystical, interpretation. Best used a massed-strings test track.

Ottorino Respighi: *Roman Festivals; Brazilian Impressions; Pines of Rome. Dallas Symphony Orchestra, Eduardo Mata, conductor. Dorian DOR-90182.*
Ottorino Respighi: *Church Windows; Brazilian Impressions; Roman Festivals. Cincinnati Symphony Orchestra, Jesús López-Cobos, conductor. Telarc CD-80356*

My principal interest here was in *Roman Festivals*, the last-composed of Respighi's Roman trilogy. It's too bad that the other two pieces of the trilogy (*Pines of Rome* and *Fountains of Rome*) are more frequently recorded because *Festivals* is by far the most sonically spectacular of the three. As music, it could well be the soundtrack for a Fellini film of Ben Hur Meets Petrushka. But as a demonstration piece, few works can match its orchestral forces or the range of massive and delicate effects they can produce.

For the record—and since neither CD's booklet prints a list (which should be required for all orchestral recordings)—Respighi's score specifies: 2 flutes, 1 flute doubling on piccolo, 2 oboes, English horn, piccolo clarinet, 2 "regular" clarinets, bass clarinet, 2 bassoons, contrabassoon, 4 horns, 4 trumpets, 2 trombones, bass trombone, tuba, timpani, tambourine, ratchet, sleigh bells, side drum, tenor drum, triangle, cymbals, bass drum with attached cymbals, tam-tam, glockenspiel, 2 bells, xylophone, 2 tavolettas (defined by the Grove dictionary as "a board or table struck with a hammer," but the Telarc

THE AUDIO CRITIC

disc seems to use standard wood blocks, soon after the beginning of the last movement), piano (2 players), pipe organ, mandolin, first and second violins, violas, cellos, and double basses. (And you wonder why multimiking has such appeal for some record producers!) Three buccinas—ancient Roman brass instruments—are also called for at the beginning of the piece. But three trumpets, the composer-suggested substitutions, are usually used instead, probably because nobody seems to know exactly what a buccina was. Valveless baroque trumpets may actually make a better substitute.

A good recording would enable you to hear every one of these instruments' contributions when they can reasonably be expected to be heard. That doesn't happen with the Dorian disc, which is saddled with virtually the same "heftless" sound quality as their recent Mahler recording (see review above). On the Respighi disc, the measured reverb time is nearly 3 seconds, which is excessive for virtually all orchestral music except possibly Bruckner's. It certainly does no good to *Festivals*, which is lost in the no-impact haze. [*Clean, natural haze, though.—Ed.*] All that sticks out is the brass, including those trumpets-cum-buccinas, and some incredibly scrawny violins ([2] 2:45 and 4:14). That's just as well, since none of Mata's sleepy performances would otherwise recommend this disc. Look to Telarc instead.

Their disc is yet another bass-drum special and easily one of Telarc's most spectacular recordings in their Grammy-studded history of engineering achievements. The sound scores highly in heft, impact, power, clarity, tonal balance, instrumental balance, realistic imaging in depth, and an appropriate ambience (2-second reverb time). There are solid musical values here also, López-Cobos managing the many tempo changes in *Festivals* as smoothly as did Toscanini (the work's first conductor). Cue to Track 8 and let 'er rip. *Ave* Telarc, those whose amplifiers are about to go into clipping *te salutant...*

Peter Ilyich Tchaikovsky: *Symphonies No. 4, 5, and 6. St. Petersburg Philhar-*
ISSUE NO. 21 • SPRING 1994

monic, Yuri Temirkanov, conductor. RCA/BMG 090226-61377.

Think of the claims for authenticity that can be made for this recording: Russian music, Russian conductor, Russian hall (possibly with "original" acoustics), and a Russian orchestra using—wonder of wonders—the "old" 19th-century seating plan for which these works were written. That plan has the first violins, cellos, and basses on the left, and the second violins and violas on the right. It results in an "opening" of the string texture, in addition to reproducing any antiphonal left-right effects the composer may have intended. Luckily, this has all been preserved in completely low-noise, low-distortion Western sound that does not artificially fill in the rather short reverb time.

The performances are excellent, overall. Temirkanov often makes exaggerated and/or unmarked tempo changes—as is customary but *not* necessarily authentic Late Romantic style—that became exasperating during the first two movements of the 5th and the first movement of the 6th. He is also a conductor who prefers the last movement of the 6th to be played in slow motion. He takes 12 minutes for a movement that usually takes around 9 to 10 minutes if Tchaikovsky's metronome markings are even vaguely followed. (But that's nothing compared with Bernstein's achingly glacial, 17-minute-plus reading in his Deutsche Grammophon recording.) Even so, close as he might come, Temirkanov never completely drops the "line," a feeling of rhythmic continuity that is difficult to convey without being able to see his "beat." And the Russianness of the horns and brass, the sensuousness of the woodwinds, the clarity of the string writing, and Temirkanov's ultrascrupulous observance of Tchaikovsky's often-ignored accentuation and phrasing instructions were more than enough to sustain my interest. Highly recommended.

Instrumental

The Renaissance Lute [music from around 1500 to 1600]. Ronn McFarlane, lute. Dorian DOR-90186.

This is the first solo album of McFarlane's that I've heard, and if his other solo discs are half as well done as this one, I'd have no hesitation at recommending the lot. Here, the excellent sound quality is of secondary consideration (just don't play it too loud, lutes are inherently soft). More important is how McFarlane's musicianship and virtuosity show up: impeccable phrasing, effortless ornamentation, spot-on tempos, and incredibly variegated tonal colors coaxed out of temperamental instruments. That musicianship also shows in the sequencing of the disc, which maintains interest despite having lots of short pieces that weren't intended for such massive doses. Even McFarlane's program notes leave us wanting more. Extraordinary.

Britteniana

Benjamin Britten: *Peter Grimes. Chorus & Orchestra of the Royal Opera House, Covent Garden; Bernard Haitink, conductor. EMI CDCB 54832.*

Benjamin Britten: *A Midsummer Night's Dream. City of London Sinfonia, Richard Hickox, conductor. Virgin 7 59305-2.*

Benjamin Britten: *Gloriana. Orchestra and Chorus of the Welsh National Opera, Sir Charles Mackerras, conductor. Argo 440 213-2.*

Peter Grimes has fared well in performance and sound on its three recordings, starting from the first with the composer conducting (on London 414 577-2). All have been models of state-of-the-art sound for when they were recorded. This EMI production—one of the best-sounding opera recordings ever—is no exception. The clarity of the orchestral pickup is of demonstration quality, yet the voices are well integrated at an appropriate distance into the image. Obtaining this type of voice/orchestra balance, where neither obscures or overpowers the other, is perhaps the most difficult task of its kind in all of classical music.

The performance has much to recommend it as well, starting with Haitink's surefire pacing and masterly control of the large orchestra. Vocally, this is the best-sung of all the *Grimes* recordings. The only problem is with the title role, sung by Antho-

ny Rolfe-Johnson. His voice is clearly more beautiful than that of either of his predecessors (Peter Pears and Jon Vickers) and he sings accurately enough. But he doesn't convey, in tonal shading or vocal pitch inflections, quite the intense anguish that Pears and especially Vickers brought to the role. A little ugliness may have helped. Highly recommended nonetheless.

Also recommendable, though less sonically faultless, is the second-ever recording of *A Midsummer Night's Dream*. While the pickup of voices and chamber orchestra (with expanded percussion section) is generally excellent, the engineers seemed to have had trouble balancing the countertenor (James Bowman, who plays Oberon). This seems to be a voice type that is unusually difficult to balance, as this problem occurs on other countertenor discs. (Or maybe he just wanted to be too unatmospherially loud.) Also, when Puck rushes in, he sometimes comes on stomping, distractingly. But the piece is marvelous, particularly the varied colors Britten obtains from the small orchestra.

Returning to a more massive scale, Britten's opera written for the coronation of Elizabeth II is about Elizabeth I (Gloriana). The work receives its first audio recording with the Argo release. I've seen it onstage (the production I attended, by the English National Opera, is available on videotape), and it is a grand piece of musical theater with a controversial ending that has Elizabeth speaking—instead of singing—what I believe are words of the historical Elizabeth I. As staged by the ENO, this produced a thrilling effect as the Queen stepped out of her "artificial" operatic world and, as a "real" person, regally yet lovingly addressed us directly, we who had now become her subjects. Unforgettable.

Argo's recording mishandles this theatrical coup. It breaks the in-theater sonic illusion it had maintained up to that point, by having Josephine Barstow speak Elizabeth's words in a close-up conversational tone. Instead of grand rhetoric we get a Barbara Walters interview. It is too intimate and incapable of creating the grand, tragic effect of a more theatrical

delivery. Forewarned, you can now safely explore the beauties of the rest of the music, which are considerable (especially the writing for the chorus).

Unfortunately, the recording quality does not come up to the very high standards set by the other two sets. The hall is somewhat boxy-sounding, the important choral pickup has individual voices sticking disharmoniously out, and an onstage procession in Act III is virtually panned mono. While excellent actors, both the main characters, Elizabeth and the Earl of Essex (Philip Langridge), have pitch problems with the inner notes of phrases, and Essex's voice often loses the sensation of specific pitch (his overtones don't line up with his fundamentals). But this opera is likely not to be recorded again for decades and is therefore self-recommending to anyone interested in Britten's music.

* * *

Editor's choice of recent releases:

Béla Bartók: *Sonata for 2 Pianos & Percussion (also works by Ernst von Dohnányi and Zoltán Kodály)*. Artists and guests of the Chamber Music Society of Lincoln Center. *Delos DE 3151*.

One of the great Bartók masterpieces, very effectively performed and sensationally recorded. Did someone say bass drum? You just wait! The Dohnányi and Kodály pieces are also far from negligible.

Gustav Hoist: *The Planets*. Royal Philharmonic Orchestra, James Judd, conductor. *Denon CO-75076*.

Possibly the best-phrased, most musical performance of *The Planets* in the digital era. The sound is more loudspeaker-sensitive than usual; on a super system it's quite wonderful.

W. A. Mozart: *Symphonies No. 35, 36, 38, 39, 40, and 41*. **Anton Webern:** *Works for orchestra*. *The Cleveland Orchestra, Christoph von Dohnányi, conductor*. *London 436 421-2*.

Intermingling the greatest symphonies of Mozart with the orchestral cameos of Webern in a three-CD set may be an off-the-wall idea, but I don't care. The Cleveland is my favorite orchestra, arguably the most virtuosic of them all; Dohnányi's per-

formances combine heart and intellect in equal proportions; the John Pellowe recordings possess both warmth and transparency. It hardly ever gets much better than this.

Igor Stravinsky: *The Composer, Vol. III, TV, and V. The Orchestra of St. Luke's & The Gregg Smith Singers, Robert Craft, conductor*. *MusicMasters Classics*.

Robert Craft continues his highly authoritative traversal of the complete works of Stravinsky with world-class orchestra players, good singers, and flawless recording. Every Stravinskyite needs the whole set.

Ludwig van Beethoven: *"The Complete Sonatas."* Richard Goode, piano. *Elektra Nonesuch 9 79328-2*.

A monumental ten-CD set by the Artur Schnabel of our time (in my humble opinion, at any rate). Profound, spellbinding performances of the utmost musicality, recorded by Max Wilcox in unexaggerated, natural, just-right sound. What a treasure!

Giuseppe Verdi: *La Traviata*. Edita Gruberova, Neil Shicoff, Giorgio Zancanaro; London Symphony Orchestra, Carlo Rizzi, conductor. *Teldec 9031-76348-2*.

A sleeper. Beautifully intimate performance that suits the character of this essentially three-singer opera. Highly rehearsed, polished studio recording, fine singing, excellent sound.

Richard Wagner: *Das Rheingold; Die Walküre*. Recorded live at the Bayreuth Festival. Bayreuth Festival Orchestra, Daniel Barenboim, conductor. *Teldec 4509-91185-2 and 91186-2; Teldec Video 4509-91122-6 and 91123-6*.

The first two sets of CDs and videodiscs of the complete Barenboim/Bayreuth *Ring*. The coming *Siegfried* and *Götterdämmerung* need to be no more than equally good to make this one of the truly important cycles in the recorded Wagner canon. Barenboim has seldom been this good; he works with excellent singing actors though no great voices; the orchestra is fabulous; and the very accurately recorded Bayreuth acoustic is clearly the only 100% right one for the *Ring*. The Unitel video production (same sound track) proves Harry Kupfer's staging to be a grotesque, self-indulgent travesty. Ugh!•

THE AUDIO CRITIC