

HiFi ENGINE[®]

For more Hi-Fi manuals and set-up information
please visit www.hifiengine.com



THE ACOUSTICAL MANUFACTURING CO., LTD.
HUNTINGDON · HUNTS. · ENGLAND
TELEPHONE: 361 & 574 TELEGRAMS: ACOUSTICAL, HUNTINGDON

INTRODUCTION

FREQUENCY MODULATION

The outstanding feature of VHF/FM transmissions is the high quality of reproduction which may be obtained when used with modern high standard amplifiers and loudspeakers.

INTERFERENCE

At the same time the system is essentially less prone than AM to interference due to both other stations and noise. Efficient suppression of interference is dependent upon adequate signal strength, however, and the aerial system should always be rather better than the minimum required to produce a signal (see Aerial).

DRIFT

Automatic frequency control of the temperature compensated local oscillator ensures that tuning drift is negligible after the initial warming up period of 30 seconds.

TUNING INDICATOR

To simplify tuning, a unique display has been developed giving a positive indication of accurate tuning, with the obvious advantage over more conventional types with which it is necessary to detune the receiver to check whether or not it was on tune. This indicator shows a tuning error of 1 part in 10,000.

DIAL

The dial shows the frequency range of the receiver (87.5 to 108 Mc/s) covering both British and American bands, and adjustable Station Indicators, which may be set to the scale readings corresponding to your own local stations, enable the required programme to be selected without having to search the band.

INSTALLATION

MOUNTING

The Tuner may be mounted in a cabinet panel of any thickness up to $\frac{3}{4}$ " (20mm.)

A 10" x 3 $\frac{1}{16}$ " (254 x 78mm.) opening with $\frac{1}{4}$ " (6mm.) radius corners should be cut in the panel, as shown in the template contained in the rear of this booklet.

Remove the two screws from the rear of the cover and slide the cover off.

Insert Tuner, leads first, into the cut-out from the front. The lugs on the rear of the Tuner front panel should locate inside the cut-out.

Replace the cover from the rear, making sure that the leads are not trapped. Insert the two screws and tighten until the Tuner is just held in position, then give one additional turn to lock securely.

CONNECTIONS

The Tuner is supplied with leads and plugs for direct connection to the QC II and QUAD 22 control units, which provide the necessary power supplies, but the Tuner may be used with other amplifiers of suitable specification (see separate note on page five).

AERIAL

The Tuner is designed for a 75 ohm aerial system using co-axial feeder to connect the aerial to the Tuner.

V.H.F. dipoles are available with a reflector, and sometimes with one or more directors. In general the weaker the received signal strength the more complex will be the aerial required. In order to choose the most suitable aerial an intimate knowledge of local reception conditions is necessary, and the advice of your dealer should be sought.

The sensitivity of this Tuner is high, and it is suitable for fringe area reception. This does not mean that at short distances an inadequate aerial may be used. For the highest quality reception the aerial system should be better than the absolute minimum required to receive a signal.

The aerial lead is connected to the co-axial socket visible through the left hand side of the cover, using the plug provided.

EARTH

The external earth connected to the control unit also serves to earth the Tuner and no separate connection is required.

HT/LT AND SIGNAL LEAD CONNECTIONS

The mains supply to the amplifier must be switched off before connecting or disconnecting the Tuner leads.

When used with the QC II control unit, the HT/LT lead (terminated by a four pin plug) should be connected to the RAD. 2 socket at the side of the unit. The signal lead (terminated by a single pin co-axial plug) should be

connected to the input 2 socket at the rear of the control unit. (If the 9 pin gramophone pickup adaptor unit has the prefix R, either input 1 or input 2 may be used, with the HT/LT lead connected to RAD. 1 or RAD. 2 respectively).

When used with the QUAD 22 control unit, the HT/LT lead should be connected to the yellow RADIO 1 HT/LT socket. The signal lead should be connected to the yellow RADIO 1 input socket.

Where stereophonic broadcasts are made using two VHF transmitters a second tuner will be required. This should be connected to the blue HT/LT socket and the blue RADIO 1 input socket. The second receiver will come into use only when the STEREO button is pressed on the control unit.

OPERATION

Switch on mains supply to the amplifier and allow two minutes for the Tuner to warm up. Tune the set in the normal way until the wanted station is heard clearly. Then finally adjust so that both tuning indicator lamps are alight, by moving the scale pointer slightly to the left if the left hand lamp is out, and vice versa.

STATION INDICATORS

The approximate tuning position of any three stations may be shown by the coloured station indicators. These are accessible immediately behind and above the tuning scale with the cover removed. The wanted station should be accurately tuned in and the station indicator moved into line with the pointer. When all three have been adjusted the cover should be replaced.

The station indicators are then used as a guide to the position of a desired programme on the scale whilst the final tuning is carried out with the aid of the tuning indicator.

USE WITH OTHER AMPLIFIERS AND CONTROL UNITS

If the Tuner is used with other makes of amplifiers it may be necessary to change the HT/LT and signal lead plugs.

The HT/LT lead contains three cores to which the following voltages should be applied :—

Green — { 6.3V LT.
Black — {

Red — Between 250V and 350V HT positive.

The screen of the co-axial signal lead is both HT negative and earth. The output signal is carried on the centre conductor of this lead. (See circuit diagram).

The audio output of the Tuner is 100 mV r.m.s. (22.5 Kc/s deviation) and the amplifier used should give full output for this voltage. The amplifier must provide a load across the Tuner output of 100,000 ohms in order to maintain the correct frequency response.

MAINTENANCE

CIRCUIT DESCRIPTION

A broad band fixed tuned transformer couples the low impedance aerial to a RF amplifier pentode (6BH6), the output of which is transformer coupled to a low noise triode (one half of 12AT7) mixer stage.

The local oscillator (other half of 12AT7) is fully temperature compensated and provides an output 10.7 Mc/s above the signal frequency. It is capacitively coupled to the mixer grid.

Both the mixer grid and local oscillator circuits are ganged and permeability tuned by special low loss cores driven from the tuning spindle via a precision worm drive mechanism.

The resultant 10.7 Mc/s IF signal at the mixer anode is transformer coupled to the automatic gain controlled first IF stage (6BJ6). A combination of critical and over-coupled circuits and a single tuned circuit in the second IF stage (6BH6) together with a close control of the Q of these circuits ensures a wide IF passband with a steep cut-off outside the band.

The second IF anode tuned circuit is coupled via a short time constant CR circuit to the limiter valve (6AU6), the anode of which contains a transformer with a capacitively centre tapped secondary winding feeding two diodes (6AL5) in a phase discriminator circuit. Again the coupling and Q are chosen to give low distortion in the audio output.

The audio signal is fed via the appropriate de-emphasis network and a DC blocking condenser to the output cable.

The DC component at the discriminator output whose magnitude is proportional to the amount of mistune and of polarity dependent upon the direction of mistune, is fed to a cathode coupled phase inverter stage (12AX7) which contains a miniature neon in each anode. Slight mistuning extinguishes one neon showing the direction of mistune while even illumination of both indicates correct tuning. In addition, this stage provides Automatic Frequency Control, one section of the double triode acting as a reactance valve across the local oscillator tuning coil.

SPECIFICATION

Tuning Range 87.5 — 108 Mc/s.

Output 100 mV at 100 K ohms impedance (to be terminated by 100 K ohms across amplifier input).

Consumption 6.3 V. 1.8 A.
330 V. 27 mA.

Valves 6BH6; 12AT7/ECC 81; 6BJ6; 6BH6;
6AU6; 6AL5/EB91; 12AX7/ECC83;
Two Hivac CC11L; lamp 6.5 v. .115 a.

Dimensions 10½" x 3½" x 6".

Weight 6 lb. (2.7 Kgs.)

ALIGNMENT INSTRUCTIONS

I.F. ALIGNMENT

Preliminary. Remove cover and chassis base plate. Remove white lead (AGC feed to IFT1) from test point B and connect lead to chassis. Unscrew primary cores (those accessible through top of can using a short trimming tool) of IFT1, IFT2, and IFT4, secondary cores (accessible from inside chassis) of IFT1, IFT2, and IFT4 and also IFT3, until core is projecting slightly from can. Note that the correct tuning point is the first one reached when the core is screwed in.

- (1) Connect a valve voltmeter (input resistance to exceed 1 Megohm) with full scale deflection of — 1 Volt to test point B. (Ignore the standing voltage of about 0.2 Volts). Apply 10.7 mc/s to V4 grid from a low source resistance (50 — 100 ohm) and tune IFT3 for maximum DC.
- (2) Connect the valve voltmeter (± 10 Volt range) to test point A. With 10.7 mc/s to V4 grid, tune IFT4 secondary for zero DC in the middle of the discriminator curve.

- (3) Tune IFT4 primary until the positive and negative discriminator peaks occur at equal frequencies when signal generator is swung either side of 10.7 mc/s.
- (4) Repeat (2) and (3) until symmetry is obtained with zero DC at exactly 10.7 mc/s.
- (5) With valve voltmeter to test point B on — 1 Volt range inject 10.7 mc/s to V3 grid. Tune primary and secondary of IFT2 for maximum DC.
- (6) With voltmeter and input as (5), connect a damping resistor of 470 ohm across IFT2 primary and tune secondary for maximum. The receiver HT should be switched off whilst handling the damping resistor in this and subsequent operations.
- (7) Transfer damping resistor to IFT2 secondary and tune primary for maximum.
- (8) Repeat (6) and (7), keeping the input signal level adjusted to give about — 1 Volt DC at B, until correctly tuned. Remove damping resistor.

- (9) Inject 10.7 mc/s to the top of T2 secondary winding (i.e., tag on coil wired to pin 2 of V2). Tune IFT1 primary and secondary for maximum DC at B.
- (10) Connect 470 ohm damping resistor to IFT1 primary and tune secondary for maximum DC at B.
- (11) Transfer damping resistor to IFT1 secondary and tune primary for maximum DC at B.
- (12) Repeat (10) and (11), again keeping signal input level adjusted to give about — 1V at B, until correctly tuned. (Note that the input level differs little from that in (8) as the mixer grid coil tuned to 88 — 108 mc/s appears in parallel with the signal). Remove damping resistor.
- (13) With signal generator swung from 10.62 to 10.78 mc/s check that the voltage at B does not vary by more than ± 2 dB about a level of — 1 Volt at 10.7 mc/s. The curve should be symmetrical about 10.7 mc/s and should fall away sharply outside the band 10.6 to 10.8 mc/s.

R.F. ALIGNMENT

Preliminary. Fit small tuning knob to allow access through panel opening to T2 and T3 cores. Reconnect white lead to test point B. Check that with tuning control fully clockwise, the pointer lies at the end of the scale line. Connect a signal generator with a source resistance of 75 ohms to the aerial input.

- (1) Inject 90 mc/s, tune receiver to 90 mc/s and adjust T3 slug until signal is heard.
- (2) Inject 111.4 mc/s and check that image is heard (i.e., oscillator signal lies 10.7 mc/s *above* signal frequency. If the image is at 68.6 mc/s then T3 slug is too far in).
- (3) Inject 106 mc/s and tune receiver until signal is heard. If received signal lies below 106 mc/s on the scale move C10 away from T3 (and vice versa).
- (4) Repeat (1), (2) and (3) until both ends of the scale are correct.
- (5) Inject 98 mc/s. Tune in signal and adjust T1 for maximum DC at B keeping input level sufficient to give about — 1 Volt at B.

- (6) Inject 90 mc/s. Tune signal in (and keep tuned in with aid of tuning indicator) and adjust T2 core for maximum DC at B.
- (7) Inject 106 mc/s. Tune signal as in (6) and adjust T2 core for increase of DC at B. If T2 requires to be screwed out then move C6 towards T2 (and vice versa).
- (8) Repeat (6) and (7) until adjusting T2 core in either direction in (7) causes DC at B to fall. Finish at (6).
- (9) Re-assemble chassis base plate, and adjust T3 core slightly to correct calibration. Replace large tuning knob and cover.

Each set is fully aligned before despatch and this procedure is intended only for subsequent re-alignment should it become necessary. No departure from this procedure is permissible and the work should be undertaken only by a competent radio service engineer.

F.M. TUNER COMPONENTS LIST

It is important that similar components be used for replacement purposes, especially as to tolerance, rating, and in the case of condensers, construction.

RESISTORS

Circuit No.	Value	Tolerance	Manufacturer	Type	Remarks	Stock No.
R.1	100 ohm	± 10%	Erie	9		305C
R.2	4.7K	± 10%	Erie	9		240D
R.3	33K	± 10%	Erie	9		209B
R.4	82K	± 10%	Erie	9		203A
R.5	2.2K	± 10%	Erie	9		250B
R.6	47K	± 10%	Erie	9		208E
R.7	10K	± 10%	Erie	9		230B
R.8	4.7K	± 10%	Erie	9		240D
R.9	120 ohm	± 10%	Erie	9		300B
R.10	33K	± 10%	Erie	9		209B
R.11	4.7K	± 10%	Erie	9		240D
R.12	100 ohm	± 10%	Erie	9		305C
R.13	33K	± 10%	Erie	9		209B
R.14	47K	± 10%	Erie	9	Part of IFT. 3	208E
R.15	1M	± 10%	Erie	9		165A
R.16	1M	± 10%	Erie	9		165A
R.17	82K	± 10%	Erie	9		203A
R.18	120K	± 10%	Erie	16		195A
R.19	120K	± 10%	Erie	16		195A
R.20	220K	± 10%	Erie	9		187A
R.21	100K	± 10%	Erie	9		200B
R.22	1.5M	± 10%	Erie	9		160C
R.23	2.7K	± 10%	Erie	9		248B
R.24	5K	± 5%	Painton	P306		238C
R.25	10K	± 10%	Erie	8		230C
R.26	10K	± 10%	Erie	8		230C

RESISTORS

Circuit No.	Value	Tolerance	Manufacturer	Type	Remarks	Stock No.
R.27	47K	± 10%	Erie	9	Part of IFT. 4	208E
R.28	1K	± 10%	Erie	9		258B
R.29	2.2K	± 10%	Erie	9		250B
R.30	1M	± 10%	Erie	9		165A

CONDENSERS

Circuit No.	Value	Tolerance ±	Manufacturer	Type	Remarks	Stock No.
C1	1000pF	20%	Hunts	B819		516C
C2	.01μF	20%	Hunts	B800		506B
C3	1000pF	20%	Hunts	B819		516C
C4	1000pF	20%	Hunts	B819		516C
C5	2.7pF	.5pF	Erie	P100A		549A
C6	22pF	5%	Suflex	HSM		543A
C7	1000pF	20%	Hunts	B819		516C
C8	47pF	5%	Suflex	HSM		534A
C9	1000pF	20%	Hunts	B819		516C
C10	15pF	5%	Erie	N330A		545A
C11	1000pF	—	Erie	B2000		516E
C12	1000pF	—	Erie	B2000		516E
C13	1000pF	—	Erie	B2000		516E
C14	27pF	5%	Suflex	HSM		540A
C15	.01μF	20%	Hunts	B810		506C
C16	27pF	5%	Suflex	HSM	Part of IFT. 1	540A
C18	.002μF	20%	Hunts	B818		515C
C19	27pF	5%	Suflex	HSM	Part of IFT. 2	540A
C20	.002μF	20%	Hunts	B818		515C
C21	27pF	5%	Suflex	HSM	Part of IFT. 2	540A
C22	.002μF	20%	Hunts	B818		515C

CONDENSERS

Circuit No.	Value	Tolerance \pm	Manufacturer	Type	Remarks	Stock No.
C23	27pF	5%	Suflex	HSM	Part of IFT. 3	540A
C24	.01 μ F	20%	Hunts	B800		506B
C25	.004 μ F	20%	Hunts	B860	Part of IFT. 3	513B
C26	47pF	5%	Suflex	HSM		534A
C28	.01 μ F	20%	Hunts	B810	Part of IFT. 4	506C
C29	47pF	5%	Suflex	HSM		534A
C30	68pF	1%	Suflex	HSM	Part of IFT. 4	529A
C31	68pF	1%	Suflex	HSM	Part of IFT. 4	529A
C32	47pF	5%	Suflex	HSM		534A
C33	.04 μ F	20%	Hunts	B858		501A
C34	1000pF	10%	Hunts	B819A	For 50 μ sec de-emphasis	516D
	1500pF	10%	Hunts	B826A	For 75 μ sec de-emphasis	515M
C35	.04 μ F	20%	Hunts	B858		501A
C36	1000pF	}	TCC	2CTH 310/W		516F
C37	1000pF					
C38	8 μ F	—	Hunts	JE403		478G
C39	1000pF	}	TCC	2CTH 310/W		516F
C40	1000pF					
C41	4.7pF	.5pF	Erie	P100A		548A
C42	1000pF	}	TCC	2CTH310/W		516F
C43	1000pF					
C44	1000pF	}	TCC	2CTH310/W		516F
C45	1000pF					

CHOKES

L1	Dubilier	666	440A
L2	Dubilier	666	440A

NOTE.—The above component details refer to FM Tuners Series B, serial number 8677 and above. For earlier models see previous issues of Instruction Booklets.

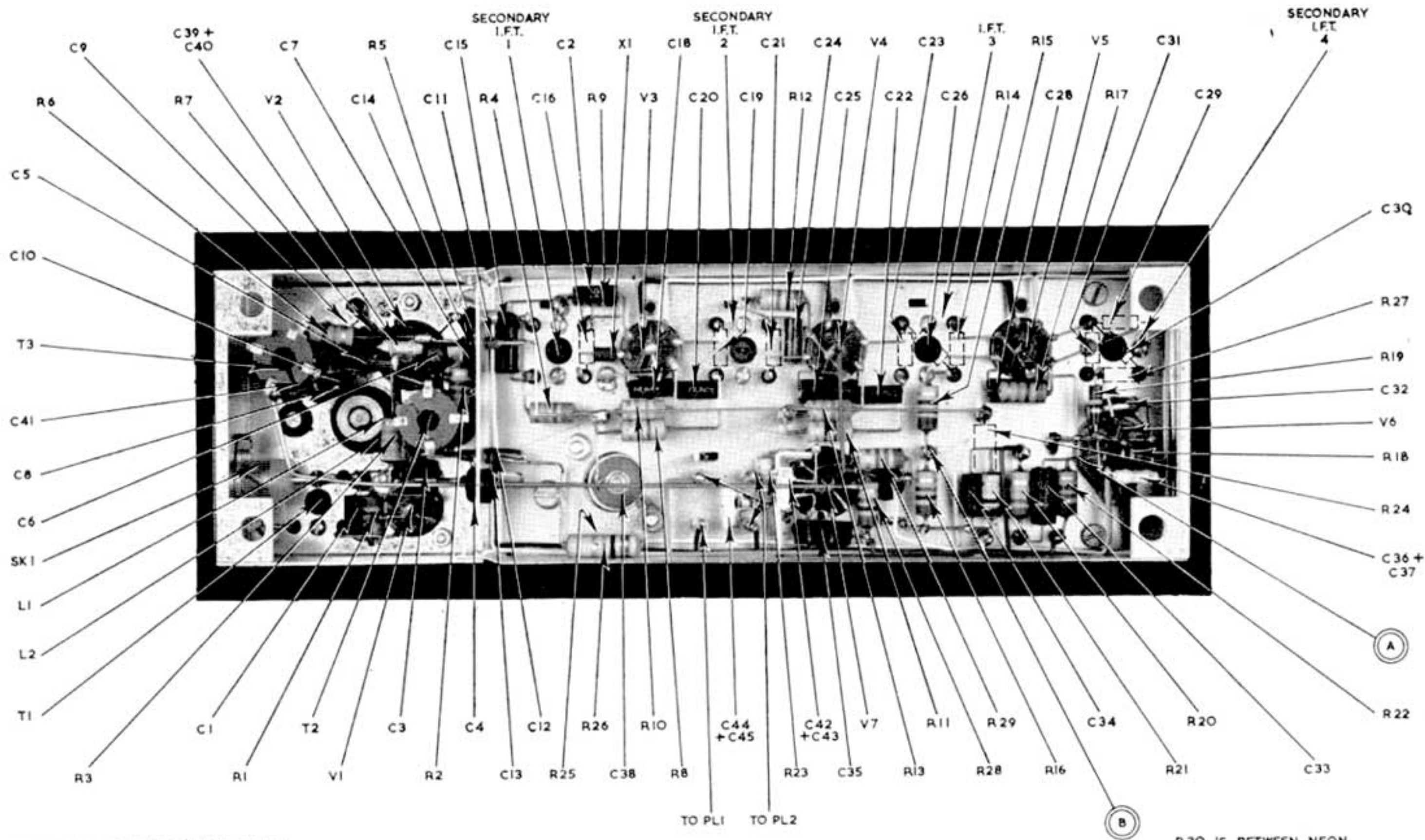

PRIMARIES OF I.F.T. 1, I.F.T. 2 & I.F.T. 4
 ARE TUNED FROM OTHER END.

R30 IS BETWEEN NEON
 INDICATORS V8 & V9

FM TUNER, SERIAL NO. 8677 AND ABOVE

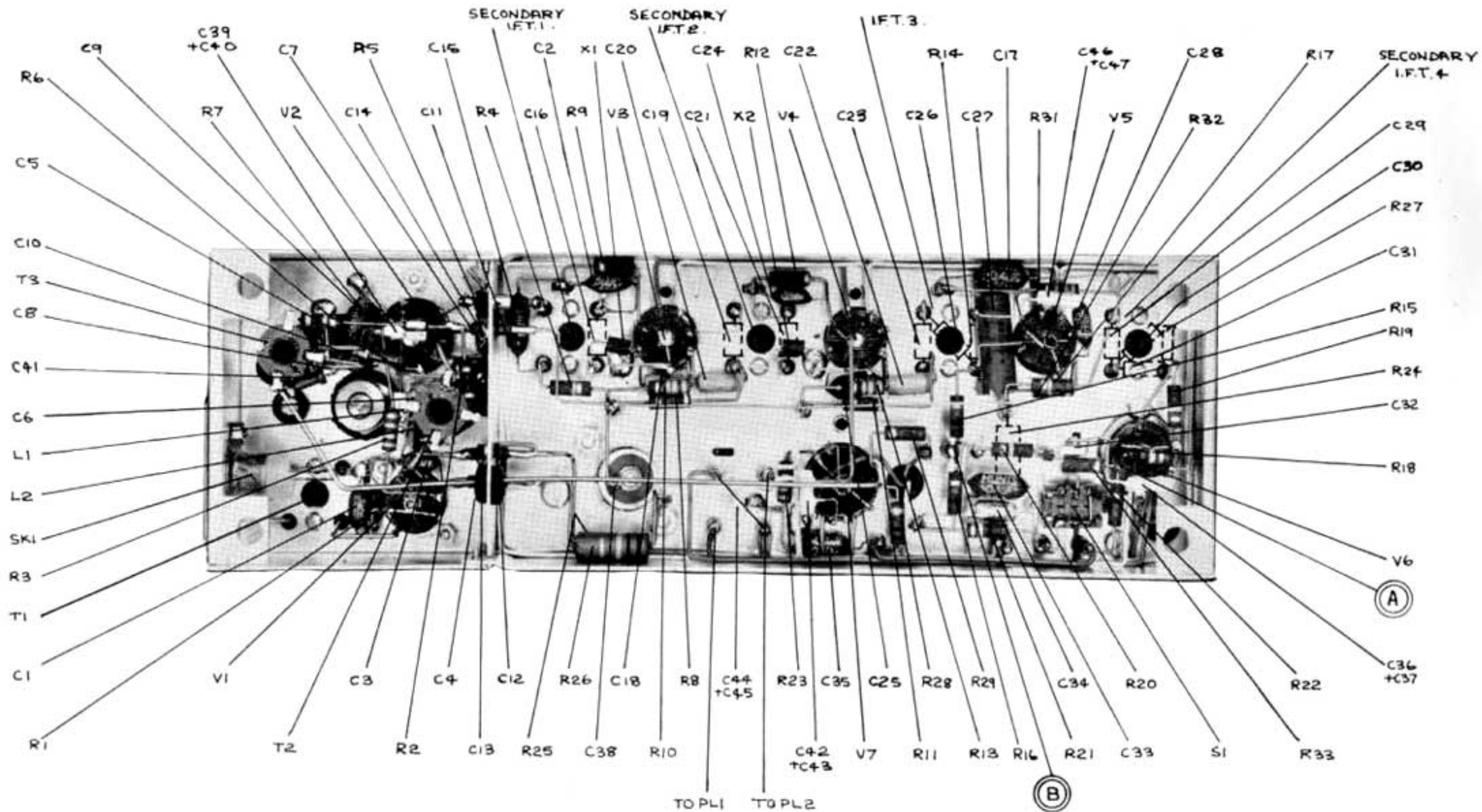

PRIMARIES OF IFT.1, IFT.2, & IFT.4
ARE TUNED FROM OTHER END.

R 30 IS BETWEEN NEON
INDICATORS V8 & V9

FM TUNER, SERIAL NO. 19062 AND ABOVE

How to load the "Belling-Lee" Coaxial Aerial Plug L.734/P

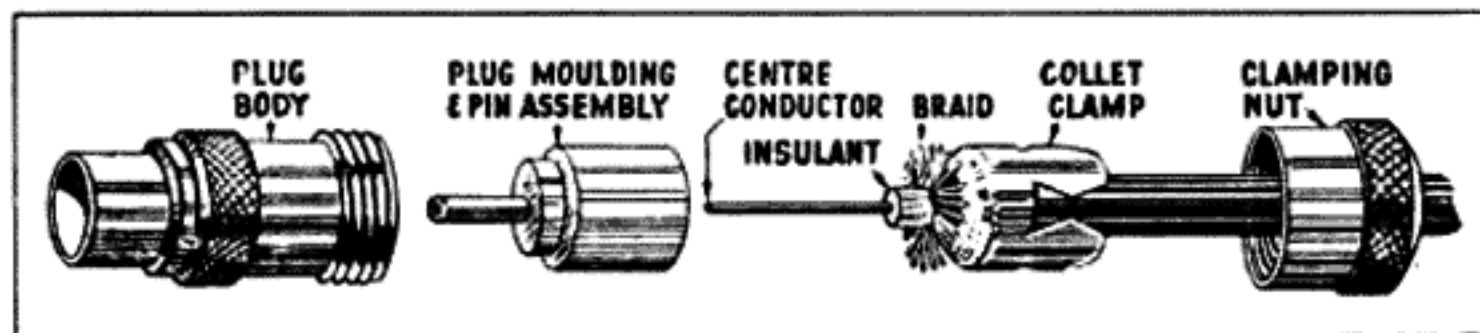

1. Trim feeder by removing 1" outer cover, $\frac{3}{4}$ " of braid and $\frac{7}{8}$ " of insulant.
2. Slide clamping nut and collet on to feeder and splay the braid.
3. Push centre conductor through plug pin as far as possible and bend sharply for soldering. Solder and trim.
4. Slide collet up to splayed ends of braid and trim braid flush with plug moulding, using knife against collet.
5. Push assembly home into plug so that collet enters it. Screw nut on firmly to grip feeder. The plug pin must be firm.
6. In the case of feeder larger than 0.261" dia. over cover, the hole in the collet clamp encircles braid only.

— ALWAYS —

- (a) Avoid scoring centre conductor and braid when removing insulant.
- (b) Solder the conductor with a quick iron, to avoid melting the cable and plug insulant.
- (c) Trim loose ends to avoid short circuiting.
- (d) Ensure that the claws of the collet are the correct way round so as to grip the outer sheath.
- (e) Avoid twisting cable when re-assembling plug, as this tends to break the conductor.

By courtesy of Belling & Lee, Ltd., Gt. Cambridge Road, Enfield, Middlesex

CIRCUIT DIAGRAM FM TUNER, SERIAL NO. 19062 AND ABOVE

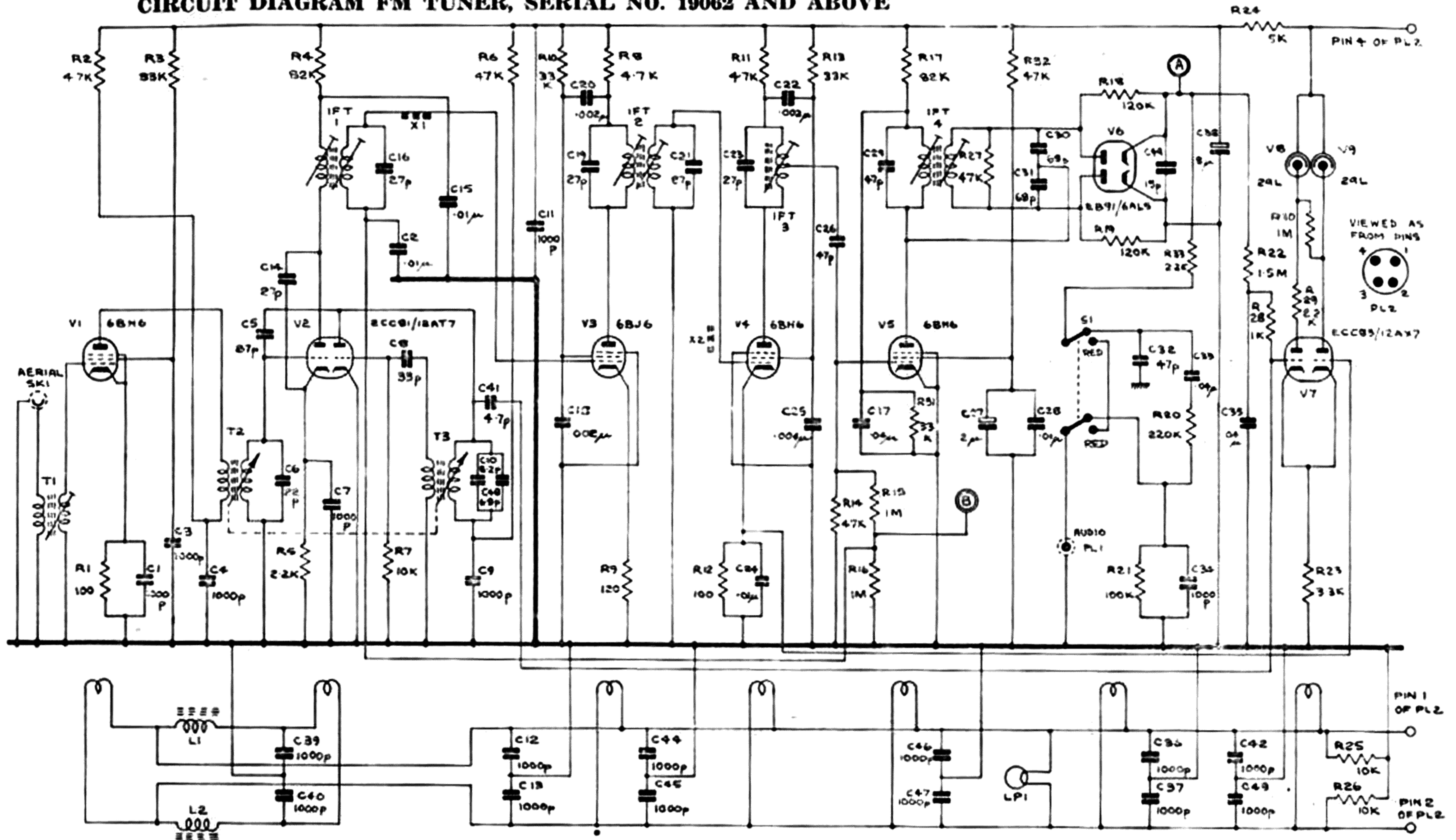

CIRCUIT DIAGRAM, F.M. TUNER, SERIES B.

