

PSW SERIES

PSW250

PSW350

PSW450

**Instruction
Manual**

**Owners of RM Series
Systems: Refer to
instructions in
"5 pack" carton**

polkaudio
The Speaker Specialists[®]

polkaudio
The Speaker Specialists[®]

**5601 METRO DRIVE,
BALTIMORE, MARYLAND 21215, USA,
800-377-7655, FAX: 410-764-5266
<http://www.polkaudio.com>**



RM0299-1

A WORD FROM MATTHEW POLK

Dear Music Lover,

Thank you for purchasing Polk Audio® speakers. Designing and building speakers is more than just a business for the people of Polk Audio—it is our passion. We are all dedicated to your complete satisfaction and delight.

Your new Polk™ speakers include the latest loudspeaker technology to assure outstanding performance and unmatched quality. Please take a moment to read through this manual for information on getting the greatest enjoyment from these fine instruments.

We make a wide variety of main, center, rear channel, powered subwoofer, and accessory speakers so you can assemble a complete and well matched high-performance surround sound system. If you would like more information on building the Polk system of your dreams, consult your Polk Audio dealer or call our Customer Service Department in North America call (800) 377-7655, Monday through Friday, 9:00am through 6:00pm Eastern time.

Sincerely,

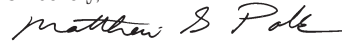

Matthew S. Polk
Chairman and Co-Founder

P.S.: A wealth of information can also be found on our award-winning web site: www.polkaudio.com.



POLK AUDIO— A HISTORY OF EXCELLENCE

Polk Audio was founded in 1972 by Matthew Polk and George Klopfer. Their dream was to make speakers with the performance of the world's best speakers, at reasonable prices. They did so by applying scientific principles to speaker design and by concentrating solely on the speaker business. That is how Polk became known as "The Speaker Specialists®."

Today Polk Audio is still headquartered in Baltimore, Maryland and is now one of the world's largest manufacturers of home and car loudspeakers. Polk's research has yielded over 20 patents for advances in loudspeaker performance and value. Polk speakers have earned the praise of audio experts the world over, as well as dozens of awards for innovative, high-quality design. Polk Audio speakers are sold in over 50 countries and in audio/video specialist retail locations throughout the U.S.

Founders Matthew Polk and George Klopfer still work alongside 300 dedicated Polk team members to bring you the best speakers you can buy.

FEATURES:

- 8"(PSW250), 10"(PSW350) or 12" (PSW450) direct radiating subwoofer driver for deep bass, smooth response and low distortion.
- Dual bass ports for deep bass and high acoustic efficiency.
- High current 50 watt (PSW250), 100 watt (PSW350) or 150 watt (PSW350) power amplifier
- Subwoofer volume control, variable crossover control and phase switch allow you to optimize performance to match your audio system, room acoustics, and program material.
- LFE input (PSW350 & PSW450)
- Switchable 80Hz high pass or full range speaker outputs (PSW450)
- Auto on-off circuit that automatically turns your subwoofer on when it senses a program signal. When no signal is present, the circuit mutes the subwoofer.

GETTING STARTED

Please inspect each loudspeaker carefully. Notify your Polk dealer if you notice any damage or missing items. Keep the carton and packing material. They will do the best job of protecting your speakers if they need to be transported.

SPEAKER PLACEMENT

Due to their compact size, Polk PSW Series subwoofers offer plenty of placement options—in an entertainment center, behind furniture or next to a sofa or chair. The subwoofer may be placed anywhere in the room, but for the greatest possible bass output, place the subwoofer in a corner of the room. The subwoofer may lay on its side, but placing it on its feet or base will yield the best performance (Figure 1). NEVER LAY THE SUBWOOFER ON THE AMPLIFIER END—THIS WILL DAMAGE THE AMPLIFIER.

The PSW250, PSW350 AND PSW450 **are magnetically shielded** and can be placed close to a television set, if necessary. However, we do not recommend placing your TV set on the subwoofer. The vibration transmitted to the TV set may shorten the life of the TV. If you see any color distortion in your TV, move the subwoofer a few inches further from the set.

CONNECTING THE SPEAKERS TO THE SYSTEM—GENERAL

If you elect to use the speaker level inputs, use two conductor 16 gauge or thicker speaker wires. If you choose to use the line level inputs, use high quality, shielded RCA type interconnect cables (see hookup options). See your Polk dealer for wire recommendations.

Note that one of the terminals on the rear of the speaker is marked red (+) and the other black (-). Make certain that you connect the wire from the red (+) terminal of your amplifier to the red (+) terminal on your speaker, and the wire from the black (-) terminal of the amplifier to the black (-) terminal on your speaker. Most wire has some indication (such as color coding, ribbing, or writing) on one of the two conductors to help maintain consistency. If your speakers sound “thin” with little bass and little to no center image, odds are that one of the speaker wires is connected backwards. Double check all connections.

Strip 1/2" of insulation from each of the two conductors on both ends to expose the bare wire. Twist the exposed wire of each conductor to form two unfrayed strands. Connect two conductors to the receiver or amp (refer to the owner's manual supplied with your electronics for assistance with proper hookup). Connect the two conductors on the other end of the wire to the speaker terminals.

FIGURE 1

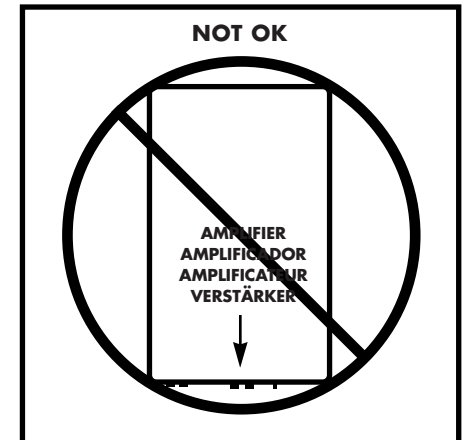
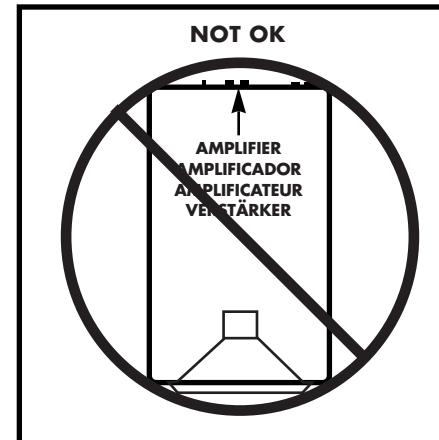
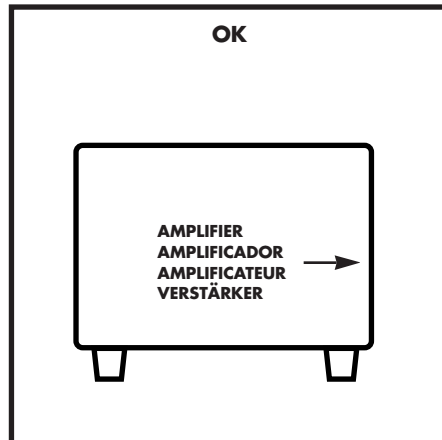
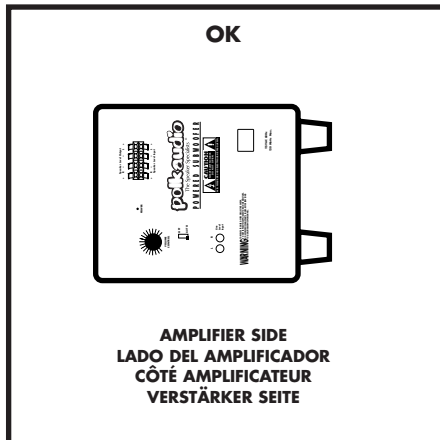

USING PUSH-TAB AND 5-WAY BINDING POST CONNECTORS

Push the plastic tab of one connector to open up the hole. Insert the bare wire into the hole, and release the plastic tab. Repeat this step for the other terminal (Figure 2).

The PSW450 uses 5-way binding posts, which operate a little differently. Unscrew the red or black nut several turns until the hole in the shaft appears. Push the bare wire into the hole and retighten nut finger tight (Figure 2a).

Make sure that the two bare wire ends do not touch each other. Such an electrical short will cause your receiver or amplifier to turn off or malfunction.

FIGURE 2 (PSW250 AND PSW350)

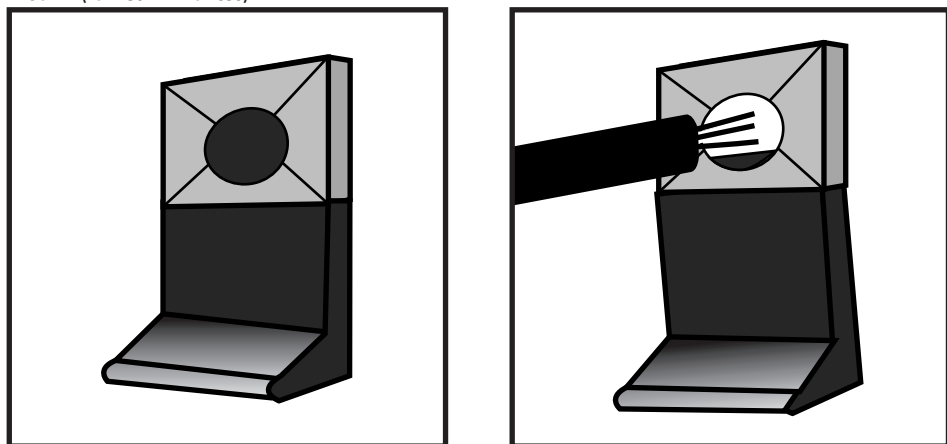
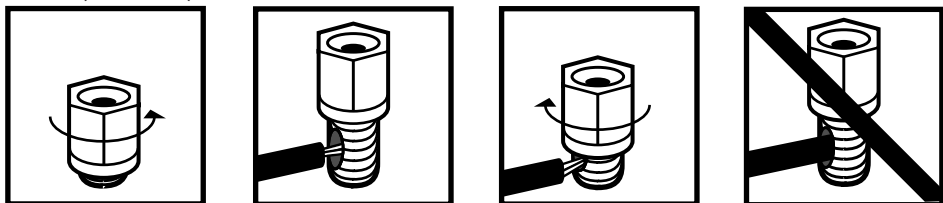

FIGURE 2A (PSW450 ONLY)



HOOK-UP OPTIONS

OPTION #1

This method is preferred for most systems and for use with the RM6200 and RM6600 systems (Figure 3).

Connect the left and right channel speaker output from your electronics to the left and right speaker level INPUT of the subwoofer. Connect the subwoofer left and right speaker level OUTPUT to the corresponding left and right speakers.

If it's easier, you can connect two sets of speaker wires from your electronics, running one set to the subwoofer and the other to the front speakers.

When using this option, it is necessary to adjust the settings of your electronics as follows: Front speakers = large, subwoofer = "OFF" or "NONE". This may sound incorrect because you have a subwoofer, but it will yield the best performance. This hookup method enables Pro Logic and Dolby Digital electronics to direct a full range signal (with bass) to the front left and right speakers (and therefore to your subwoofer) along with the LFE channel.

**OPTION #1
PREFERRED
HOOKUP**

This method is the most popular when using a receiver or amplifier.

FIGURE 3

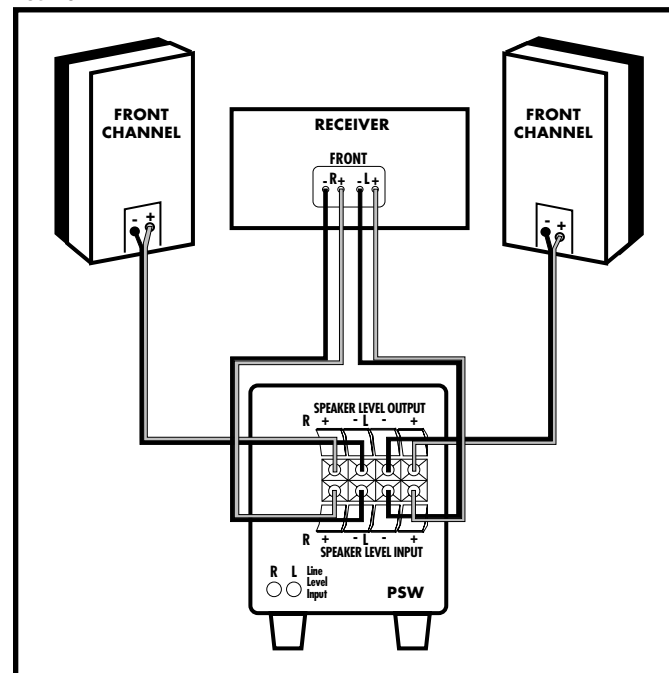

HOOK-UP OPTIONS

OPTION #2

This method can be used with electronics that include a "SUB OUT" feature (Figure 4, previous page). It is not recommended for use with RM6200 or RM6600 Systems.

Connect a single RCA cable from the "SUB OUT" of your electronics to the LFE input of the subwoofer. This input bypasses the subwoofer's variable low pass filter and relies on the filter built into your electronics. If your "SUB OUT" is an unfiltered signal (check your owner's manual), use either left or right "Line Level Input," to use the low pass crossover in the subwoofer.

When using option #2, it is necessary to adjust the settings of your electronics as follows: Front speakers = large or small depending on their output capabilities; Subwoofer = "ON".

OPTION #2 SUB OUT HOOKUP PSW350 AND PSW450 ONLY

This method is for use with electronics that include a "sub out" feature.

FIGURE 4

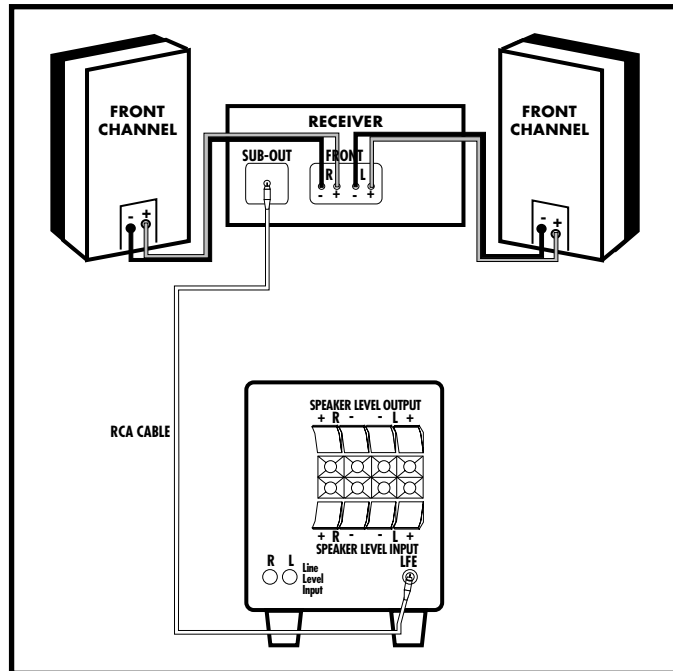

HOOK-UP OPTIONS

OPTION #3

This method is for use with electronics featuring a "PRE OUT" – and may be used as a secondary hook up method for use with RM6200 or RM6600 Systems. Connect the left and right preamp output from your electronics to the left and right LINE LEVEL input of the subwoofer. This may require use of RCA "Y" cables (not supplied) to hookup both the subwoofer and your electronics (PSW250, PSW350, PSW450). When using option #3, it is necessary to adjust the settings on your electronics as follows: Front speakers = LARGE Subwoofer = "OFF" or "NO".

OPTION #3 PRE OUT HOOKUP

This method is for use with electronic components featuring a pre-out.

FIGURE 5

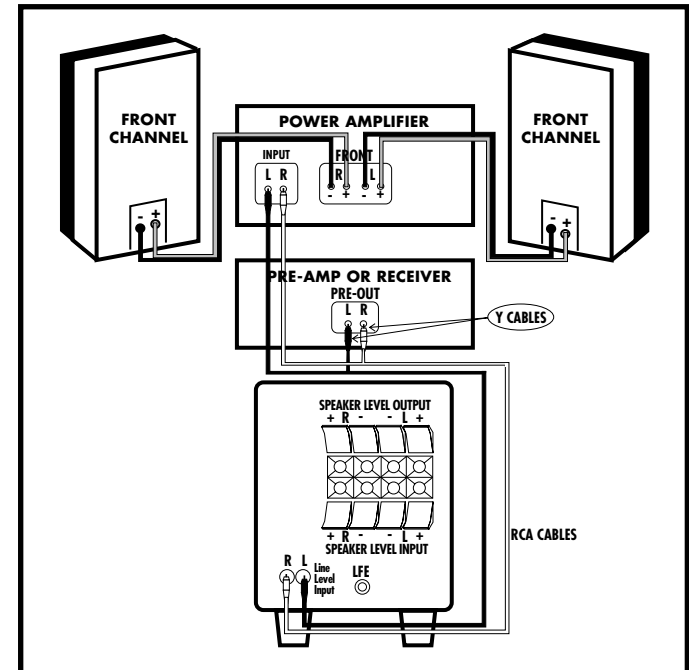

HOOK-UP OPTIONS

OPTION #4

(PSW450 Only) – Not recommended for use with RM6200 and RM6600 systems. The PSW450 offers a “switchable high pass filter” at 80Hz for those situations where you choose to limit the lower bass content directed to your front left and right speakers. The benefit can be greater dynamic range from the front left and right speakers because they are not being asked to produce any bass frequencies below 80Hz.

This hookup would be the same as Option #1, but with the switch turned to “80Hz.” See figure 6. Consult your dealer or Polk Audio customer service if you have questions about the use of this feature.

OPTION #4 PSW450 ONLY

This method is recommended for use with the PSW450. See hookup diagram for “option #1”: Figure 3, page 6.

FIGURE 6

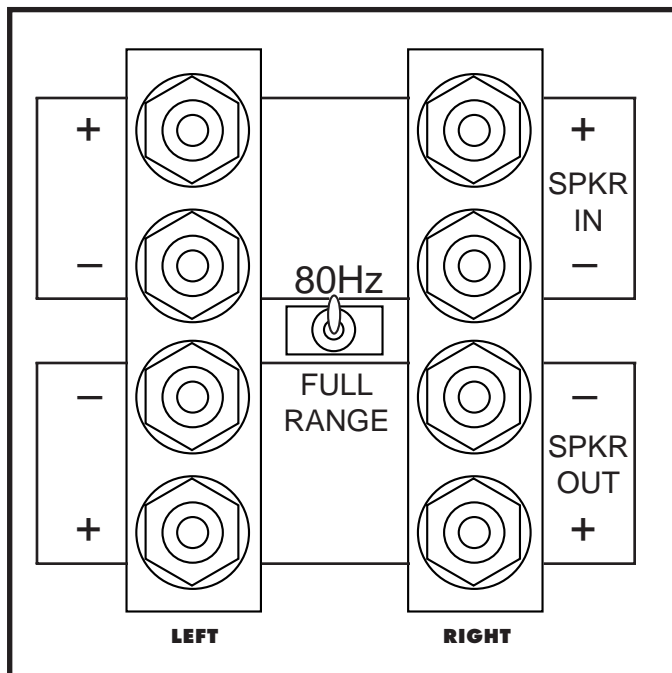

AC POWER CONNECTION AND AUTO ON/OFF

PSW250, PSW350 and PSW450 models sold within North America are designed to be connected to 110-120 volt AC outlets.

Units destined for countries outside of North America that use 220-240 volts are factory preset for 220-240 volt operation. If you do not know your local supply voltage, consult your Polk Audio dealer before connecting the amplifier to the supply or to your other hi-fi components.

AUTO MUTE CIRCUIT

The PSW250, PSW350 and PSW450 feature auto on/off circuitry, marked “auto” on the power switch, that automatically turns your subwoofer on when it senses a program signal. When no signal is present, the circuit turns the subwoofer off after a few minutes. If you are concerned about the brief delay between when the music starts and when the subwoofer turns on, simply leave your subwoofer in the “on” position.

ADJUSTING THE PSW250/PSW350/PSW450

- For RM6600 and RM6200 adjustments please refer to their owners manuals.
- Volume—Adjust by ear using a wide variety of CDs and video sources. Adjust for deep, powerful bass without “boominess.”
- Low Pass—This control adjusts the frequency range over which the subwoofer operates. When using smaller main speakers, the upper range of the control will probably yield the best results. With larger speakers, the lower end of the control range will probably sound best, but always let your ear be the final judge. If male vocals sound “thin,” turn this control up until the voice sounds rich but not boomy. If male vocals sound too “thick” or “chesty,” turn this control down until the voice sounds natural.

- Phase Switch—Have someone else switch between the two settings while you sit in your favorite listening position. Use music with good bass and a deep male vocal. When you hear the best balance of deep bass and natural lower octaves of the male voice, you have achieved optimum phase tuning.

MAINTAINING THE APPEARANCE OF PSW SERIES SPEAKERS

Your new speaker cabinet is made of a rugged material that can be dusted or cleaned with a moist cloth. Avoid harsh detergents and cleaning fluids, they can permanently damage your speakers’ finish.

TECHNICAL ASSISTANCE OR SERVICE

If, after following the hook-up directions, you experience difficulty, please double check all wire connections. Make sure that your electronic equipment is operating correctly by hooking up another speaker to the speaker output. For example, if you are not getting sound from the left channel speaker, connect the right channel speaker to the left output. If you still get no sound from that side, the problem is in your amp, receiver or source electronics. Should you isolate the problem to the speaker, contact the authorized Polk Audio dealer where you made your purchase. Authorized Polk Audio dealers are the best source for advice and assistance.

Our customer service representatives are happy to answer your questions and provide fast, friendly service. In North America call (800) 377-7655, Monday through Friday, 9:00am through 6:00pm Eastern time. Or you can E-Mail us at our Internet service address: polkcs@polkaudio.com.

TROUBLE SHOOTING

PROBLEM

No Bass

Possible Solution

- Check AC plug and green LED on the back; make sure outlet is operational
- Check volume control on subwoofer
- For speaker level wire connections, check (+) on amplifier to (+) on subwoofer and do the same for (-) to (-)
- Check that RCA line level inputs of the subwoofer are not wired from speaker level outputs of amplifier

Excessive
Mid-bass

- Turn crossover frequency down
- Move phase switch to "REV" and compare

Not
Enough
Bass

- Turn volume up on subwoofer
- Move subwoofer into corner
- Move phase switch to "REV" and compare

Hum from
Subwoofer

- Secure all wire and line level connections
- Route all speaker and/or line level connections away from AC wires
- Check for bad RCA phono cable (hookup option 2,3,4)

SPECIFICATIONS

PSW250

Driver Complement:
1 - 8" (203.2mm) woofer

Amplifier Power*:
FTC Rated Amplifier Power:
50 watts continuous into 4ohms @ .03% 30 - 200Hz

Dynamic Power:
125 watts

Calculated Maximum Output (in-room):
105dB

Enclosure Type:
direct radiating, vented

Port Type:
dual, rear firing

Overall Frequency Response:
30Hz - 180Hz

-3dB Limits:
40Hz - 160Hz

Crossover Frequency:
adjustable 80Hz - 160Hz

Phase Control:
switch 0° or 180°

Inputs:
speaker and line level

Outputs:
speaker level

Available Finish:
black

Dimensions:
(includes binding posts & heat sinks)
13"H x 11 1/2"W x 18 1/2"D
330.2mmH x 292.1mmW x 469.9mmD

Shipping Weight:
33lbs • 15kg

SPECIFICATIONS

PSW350

Driver Complement:
1 - 10" (254mm) woofer

Amplifier Power*:
FTC Rated Amplifier Power:
100 watts continuous into 4ohms @ .05% 30 - 200Hz

Dynamic Power:
260 watts

Calculated Maximum Output (in-room):
110dB

Enclosure Type:
direct radiating, vented

Port Type:
dual, rear firing

Overall Frequency Response:
25Hz - 180Hz

-3dB Limits:
38Hz - 160Hz

Crossover Frequency:
adjustable 60Hz - 160Hz

Phase Control:
switch 0° or 180°

Inputs:
speaker, LFE and line level

Outputs:
speaker level

Available Finish:
black

Dimensions:
(includes binding posts & heat sinks)
15"H x 13 1/2"W x 18 1/2"D
381mmH x 342.9mmW x 469.9mmD

Shipping Weight:
40lbs • 18.2kg

SPECIFICATIONS

PSW450

Driver Complement:
1 - 12" (304.8mm) woofer

Amplifier Power*:
FTC Rated Amplifier Power:
150 watts continuous into 4ohms @ <1% 30 - 200Hz

Dynamic Power:
350 watts

Calculated Maximum Output (in-room):
113dB

Enclosure Type:
direct radiating, vented

Port Type:
dual, rear firing

Overall Frequency Response:
25Hz - 160Hz

-3dB Limits:
35Hz - 125Hz

Crossover Frequency:
adjustable 60Hz - 125Hz

Phase Control:
switch 0° or 180°

Inputs:
speaker, LFE and line level

Outputs:
speaker level (switchable 80Hz or full range)

Available Finish:
black

Dimensions:
(includes binding posts & heat sinks)
17 1/2"H x 15"W x 19"D
444.5mmH x 381mmW x 482.6mmD

Shipping Weight:
45lbs • 20.5kg

**This specification conforms to Federal regulations regarding amplifier power ratings. For purposes of comparison, be certain that all power ratings conform to these stringent FTC regulations. Power ratings alone cannot predict actual sound output. For this reason we also specify the calculated maximum sound output.*

POLK AUDIO LIMITED WARRANTY

Polk Audio, Inc., warrants to the original purchaser only that the **Amplifier** in this Polk Audio Loudspeaker Product (the "Product") will be free from defects in material and workmanship for a period of three (3) years from the date of original retail purchase from a Polk Audio Authorized Dealer. Polk Audio, Inc., further warrants to the original purchaser only that the **Loudspeaker(s)** in this Polk Audio Product (the "Product") will be free from defects in material and workmanship for a period of five (5) years from the date of original retail purchase from a Polk Audio Authorized Dealer. The original retail purchaser shall hereinafter be referred to as "you." However, this Warranty will automatically terminate prior to the expiration if you sell or otherwise transfer the Product to any other party. The original retail purchaser shall hereinafter be referred to as "you." To allow Polk Audio to offer the best possible warranty service, please fill out the Product Registration Card(s) and send it to the Factory, at the address provided on the Product Cards(s) within ten (10) days of the date of purchase.

Defective Products must be shipped, together with proof of purchase, prepaid insured to the Polk Audio Authorized Dealer from whom you purchased the Product, or to the Factory at 2550 Britannia Boulevard, Suite D, San Diego, California 92154. Products must be shipped in the original shipping container or its equivalent; in any case the risk of loss or damage in transit is to be borne by you. If upon examination at the Factory or Polk Audio Authorized Dealer it is determined that the unit was defective in materials or workmanship at any time during this Warranty period, Polk Audio or the Polk Audio Authorized Dealer will, at its option, repair or replace this Product at no additional charge, except as set forth below. All replaced parts and Products become the property of Polk Audio. Products replaced or repaired under this warranty will be returned to you, within

a reasonable time, freight prepaid.

This warranty does not include service or parts to repair damage caused by accident, disaster, misuse, abuse, negligence, inadequate packing or shipping procedures, commercial use, voltage inputs in excess of the rated maximum of the unit, cosmetic appearance of cabinetry not directly attributable to defect in materials or workmanship, or service, repair, or modification of the Product which has not been authorized or approved by Polk Audio. This warranty shall terminate if the Serial number on the Product has been removed, tampered with or defaced.

This warranty is in lieu of all other expressed Warranties. If this Product is defective in materials or workmanship as warranted above, your sole remedy shall be repair or replacement as provided above. In no event will Polk Audio, Inc. be liable to you for any incidental or consequential damages arising out of the use or inability to use the Product, even if Polk Audio, Inc. or a Polk Audio Authorized Dealer has been advised of the possibility of such damages, or for any claim by any other party. Some states do not allow the exclusion or limitation of consequential damages, so the above limitation and exclusion may not apply to you.

All implied warranties on this Product are limited to the duration of this expressed Warranty. Some states do not allow limitation on how long an implied Warranty lasts, so the above limitations may not apply to you. This Warranty gives you specific legal rights, and you also may have other rights which vary from state to state.

This Warranty applies only to Products purchased in the United States of America, its possessions, and U.S. and NATO armed forces exchanges and audio clubs. The Warranty terms and conditions applicable to Products purchased in other countries are available from the Polk Audio Authorized Distributors in such countries.

"Polk Audio," "The Speaker Specialists," "Signature Reference Theater" and "SRT" are trademarks of Britannia Investment Corporation used under license by Polk Audio Incorporated.