

McIntosh

MAC 1700

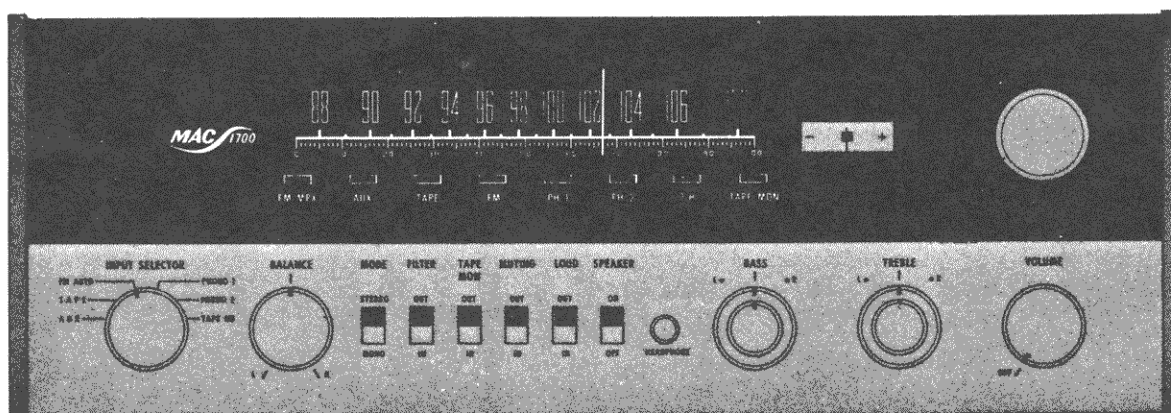

SERVICE INFORMATION

STARTING WITH SERIAL NO. 85J01

McINTOSH AUDIO COMPANY, 2 CHAMBERS STREET BINGHAMTON, NEW YORK

MAC 1700

ELECTRICAL SPECIFICATIONS

FM TUNER SECTION

USABLE SENSITIVITY

(at 100% modulation) 2.5 μ V (IHF standards)

SIGNAL TO NOISE AND HUM RATIO

65dB

HARMONIC DISTORTION

Mono, less than 0.5%. Stereo, less than 0.8%

DRIFT

Less than 25kHz

FREQUENCY RESPONSE

Flat from 20Hz to 20kHz with standard 75 micro second de-emphasis and 19kHz pilot frequency filter.

CAPTURE RATIO

Better than 2dB

IMAGE REJECTION

Better than 60dB

STEREO SEPARATION

Better than 30dB at 1kHz

AMPLIFIER SECTION

POWER OUTPUT

40 watts RMS continuous per channel with both channels operating simultaneously into 4 ohm or 8 ohm loads, 80 watts RMS continuous monophonic, 30 watts RMS continuous per channel with both channels operating simultaneously into 16 ohm loads, and 60 watts RMS continuous.

HARMONIC DISTORTION

Less than 0.25% at rated power output from 30Hz to 20kHz with both channels operating.

INTERMODULATION DISTORTION

Less than 0.25 for any combination of frequencies from 30Hz to 20kHz if instantaneous peak power is 80 watts per channel or less into 4 or 8 ohm loads and 60 watts per channel or less into 16 ohm loads with both channels operating.

FREQUENCY RANGE

At rated output both channels: +0.5dB 20Hz through 20,000Hz. +0, -3dB 10Hz through 80,000Hz.

OUTPUT IMPEDANCE

4 ohms, 8 ohms, 16 ohms, no impedance switching required.

INTERNAL IMPEDANCE AND DAMPING

Less than 0.04 ohms; damping factor greater than 100.

INPUT SENSITIVITY AND IMPEDANCE

Auxiliary, tape, tuner, and tape monitor: 300mV, 250K ohms.

Phono 1 and Phono 2: 2.4mV, 47,000 ohms

Tape Head: 2.4mV, 1/2 megohm

TOTAL NOISE

High level inputs: 75dB below rated output.
Low level inputs: 76dB below 10mV input; equivalent to less than 1.5 microvolts at input.
Power amplifier 90dB below rated output.

TAPE OUTPUT

Tuner, 1.5 volts. High level inputs, 300mV with rated input. Low level inputs, 1.3 volts with 10mV input at 1kHz.

BASS CONTROLS

+18dB at 20Hz

TREBLE CONTROLS

+18dB at 20kHz

FILTER

Flat or 5,000Hz and 60Hz cutoff at 12dB per octave.

POWER REQUIREMENTS

117 volts, AC, 50/60Hz 70-270 watts.

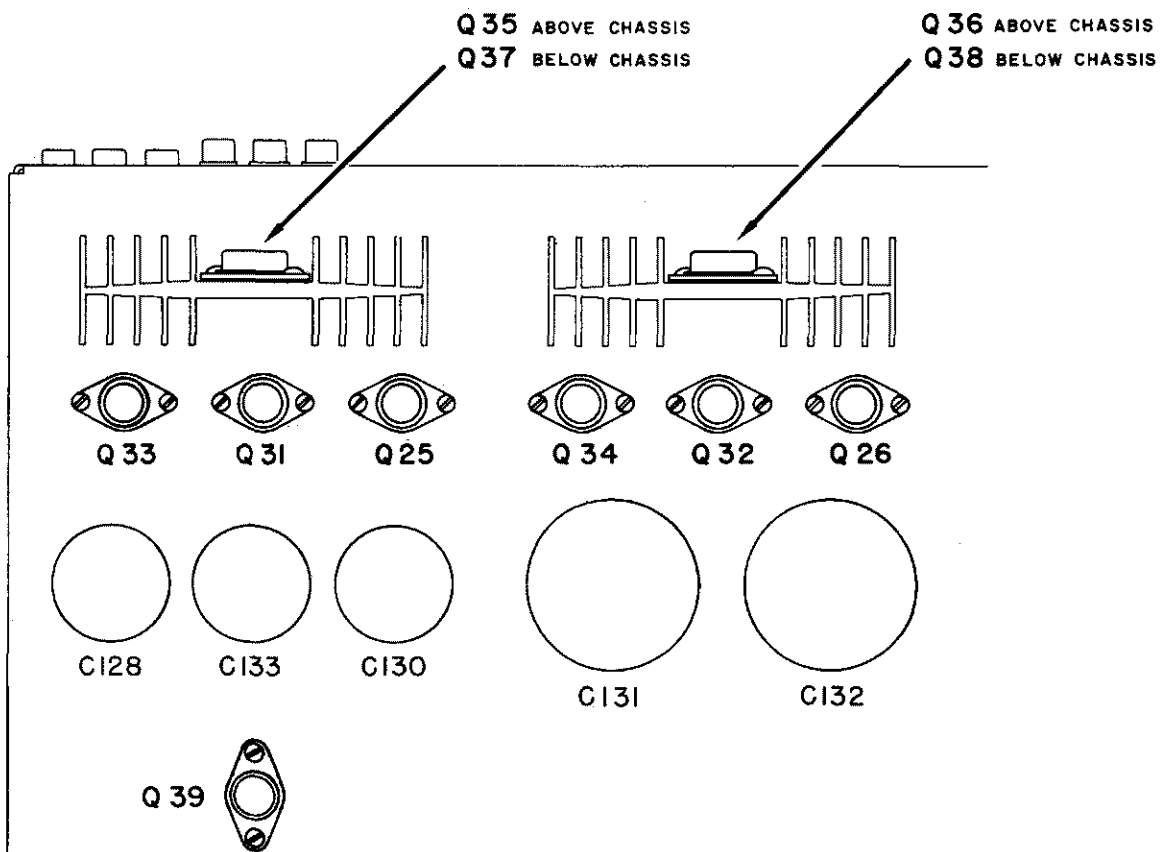
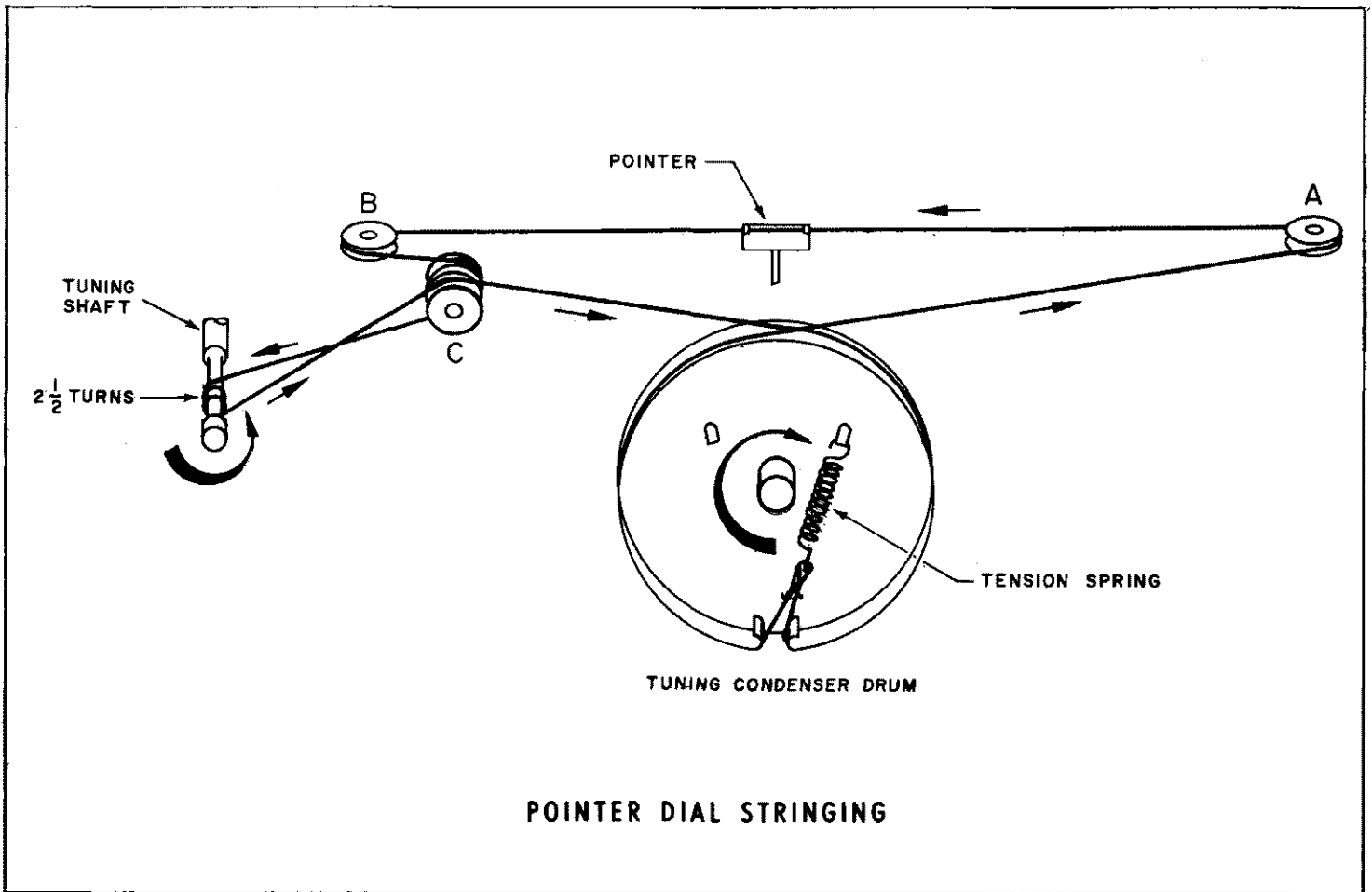

LOCATION OF TRANSISTORS NOT ON PRINTED CIRCUIT BOARDS

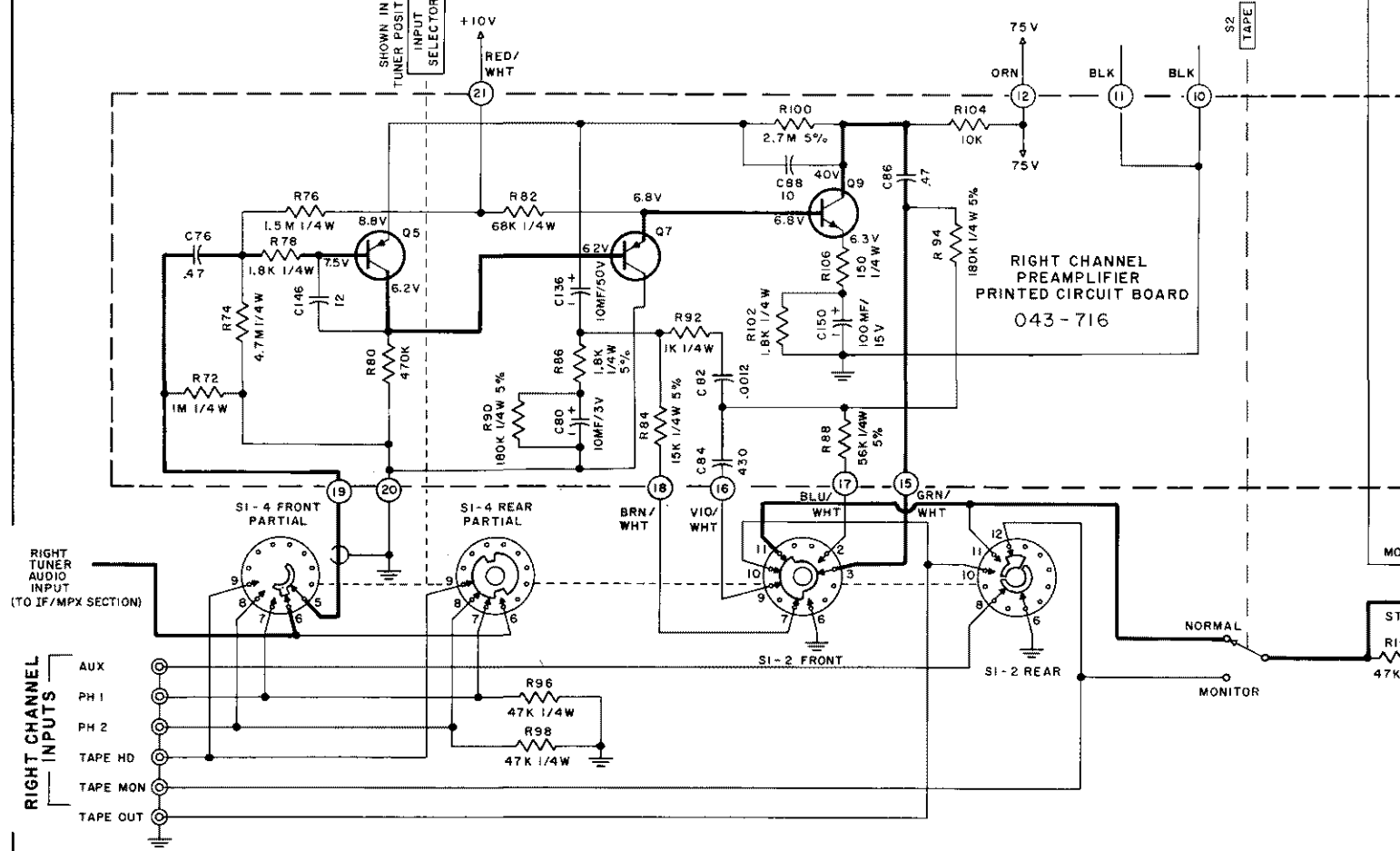
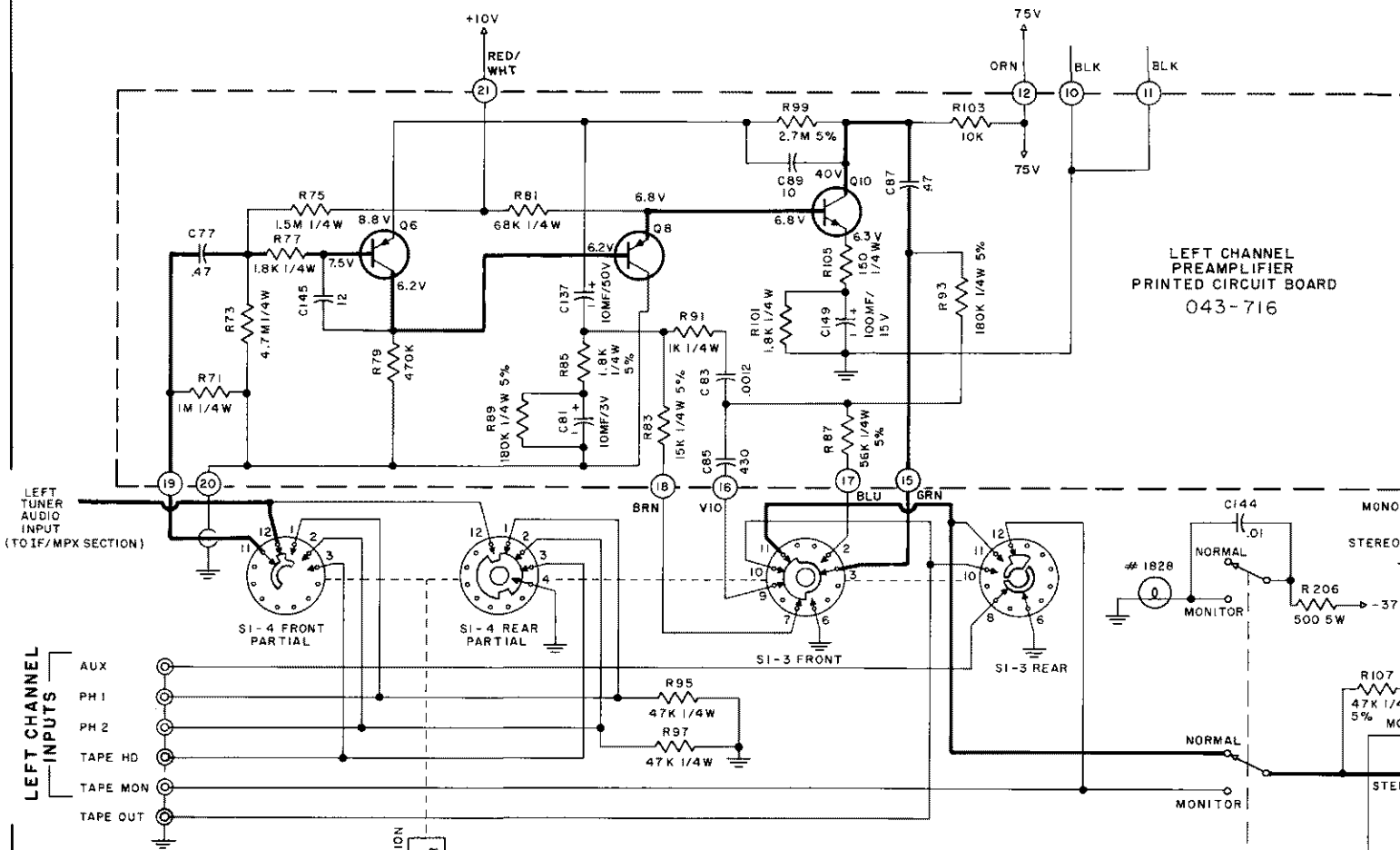

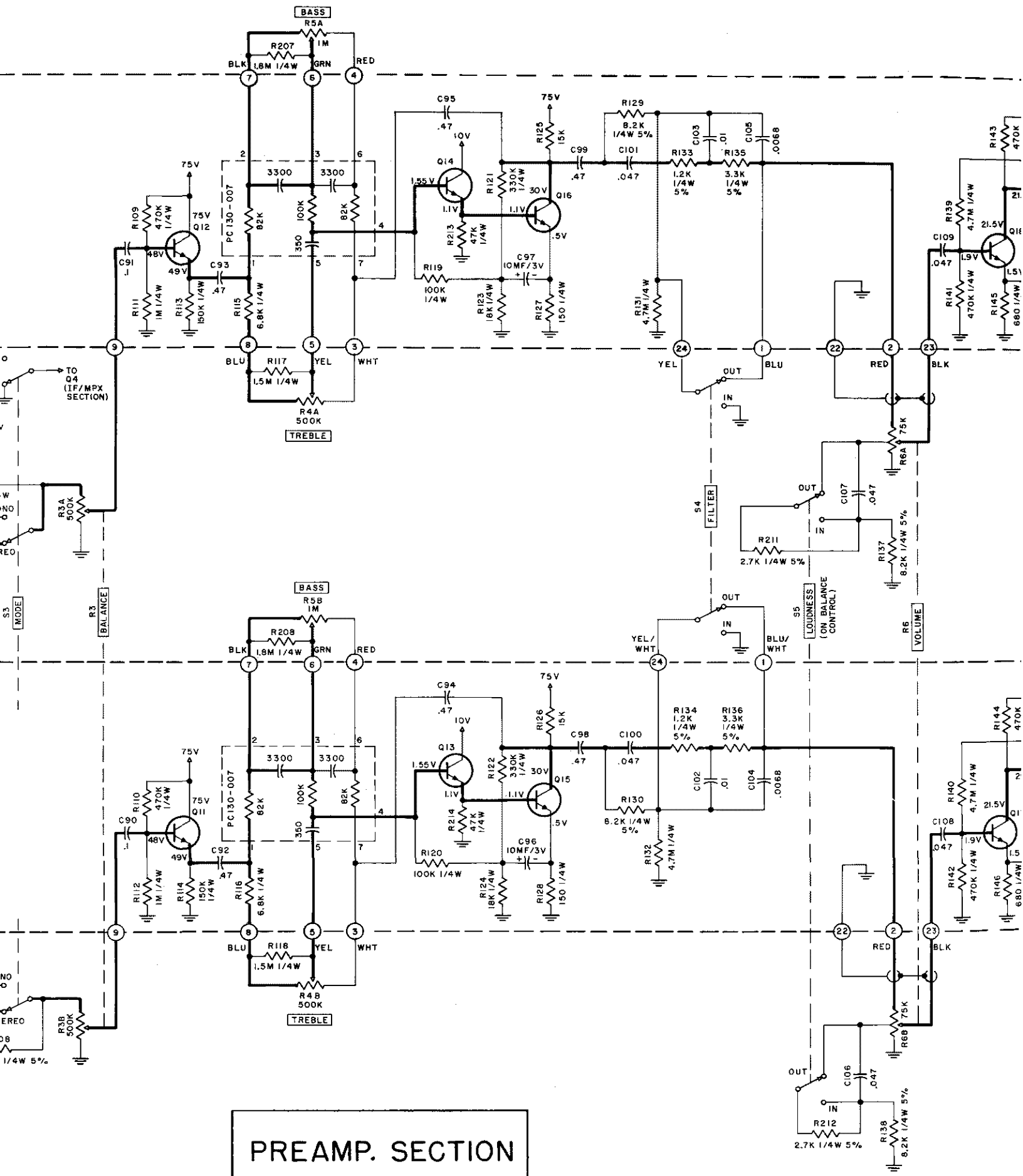

PREAMP. SECTION

MAC 1700

154 - 392

HEAVY LINE SHOWS PRIMARY SIGNAL PATH

IF/MPX INPUT OUTPUT OF RF SECTION)

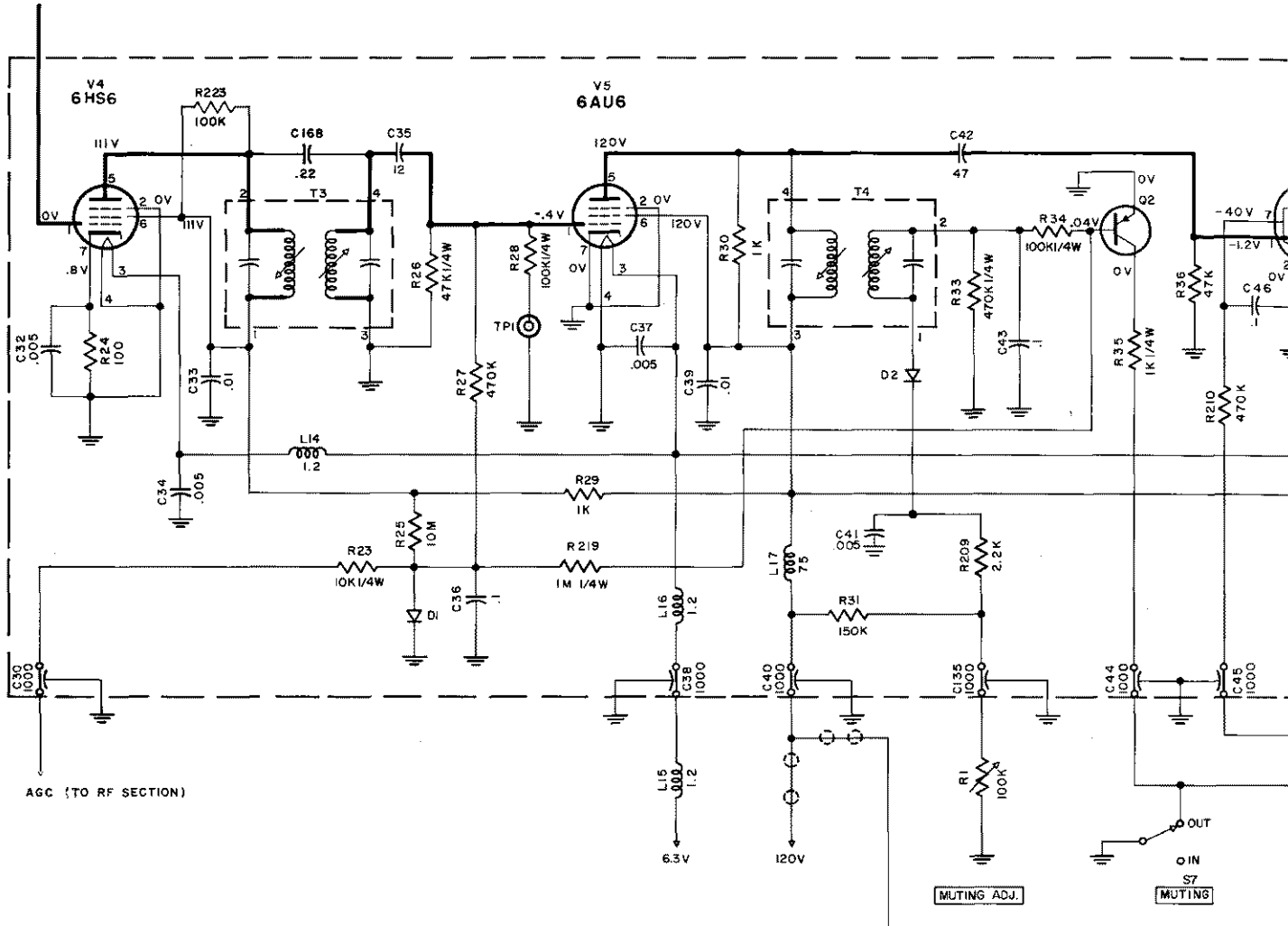

IF / MPX CHASSIS OUTLINE

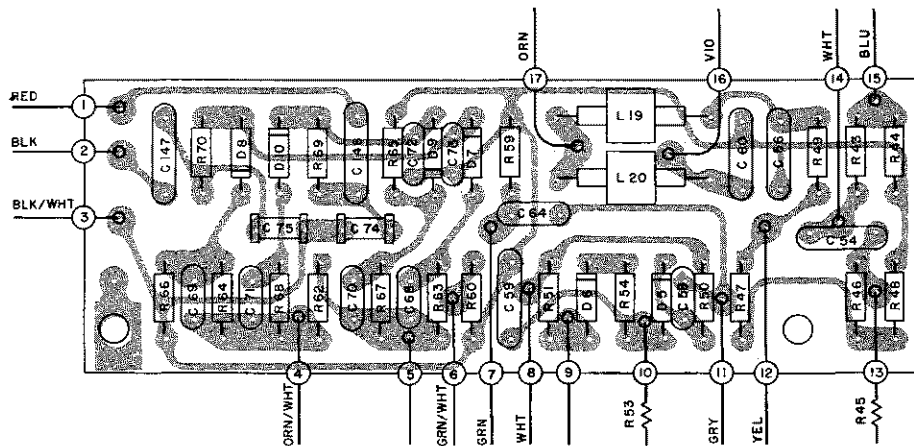
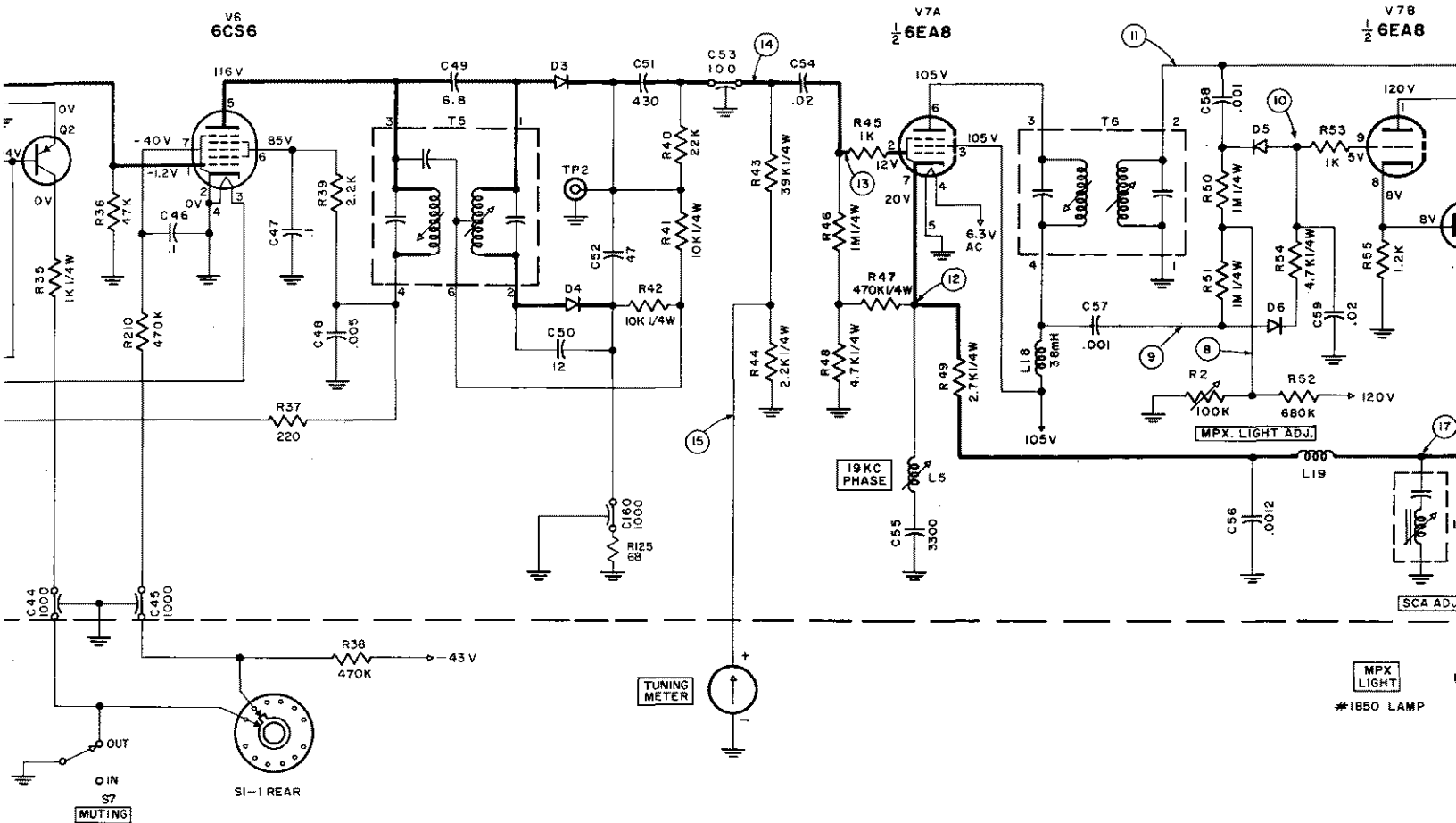

IF/MPX SECTION PRINTED CIRCUIT BOARD 043-717

RF SECTION CHASSIS OUTLINE

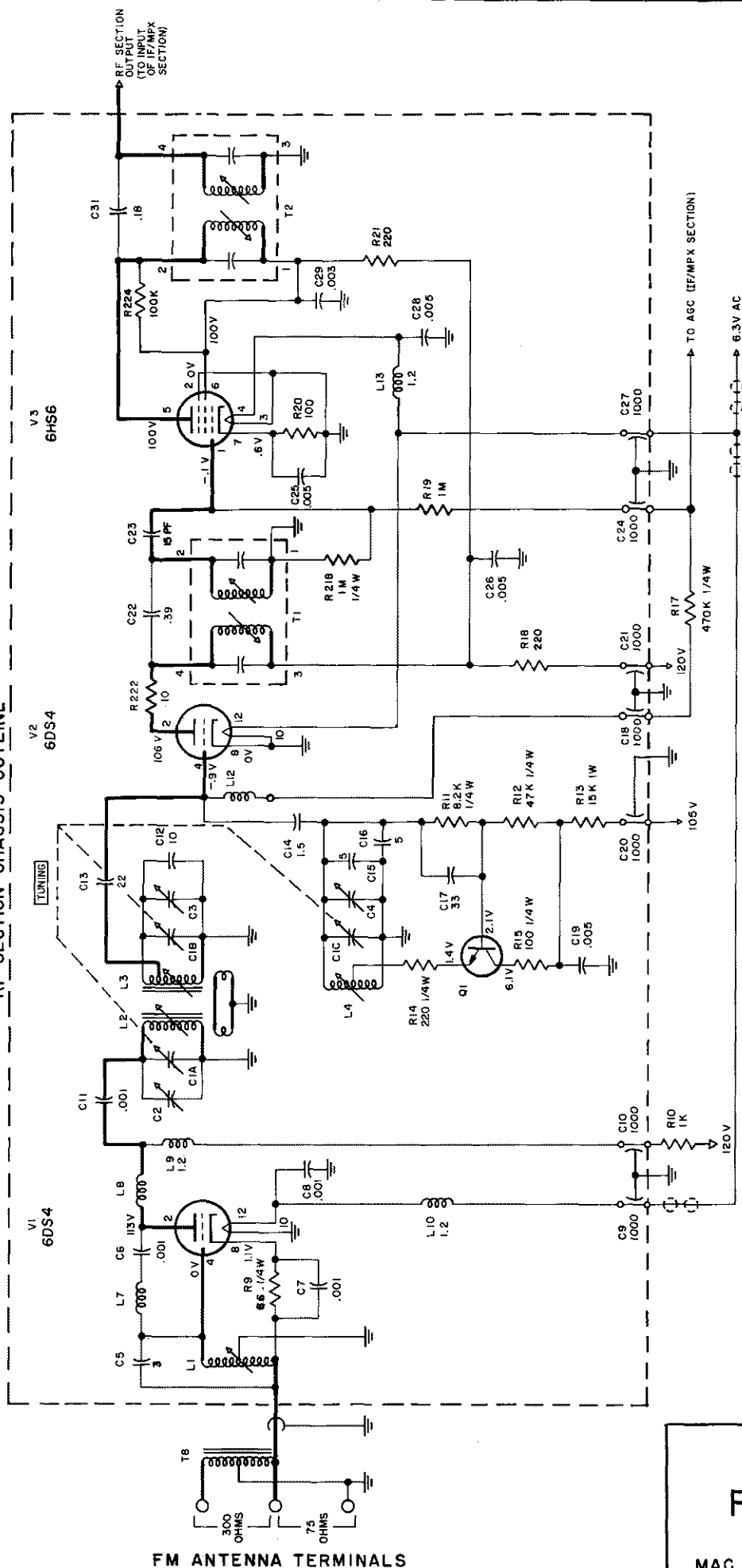

HEAVY LINE SHOWS PRIMARY SIGNAL PATH

RF SECTION

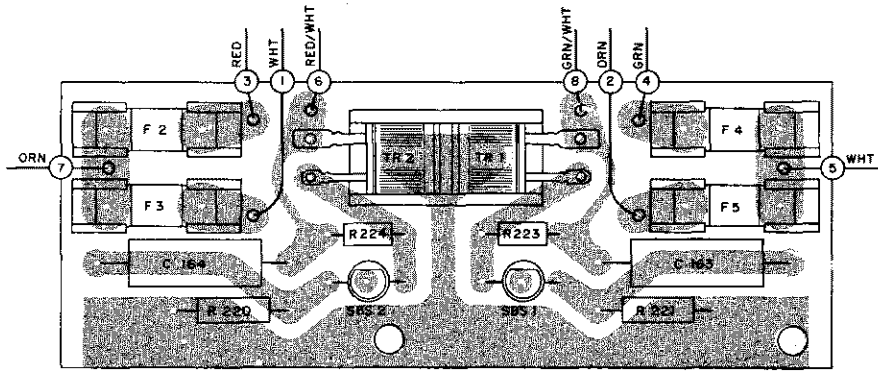

OUTPUT MONITOR PRINTED CIRCUIT BOARD 043-821

(NOTE 7)

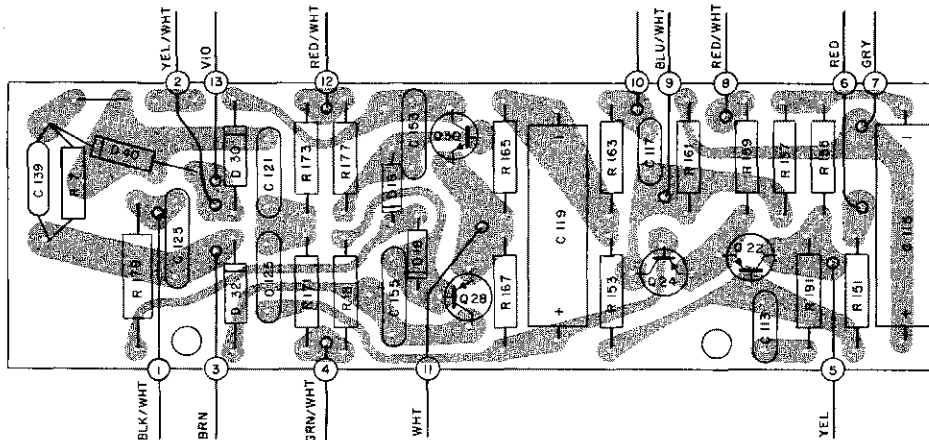

LEFT CHANNEL POWER OUTPUT SECTION PRINTED CIRCUIT BOARD

043-910

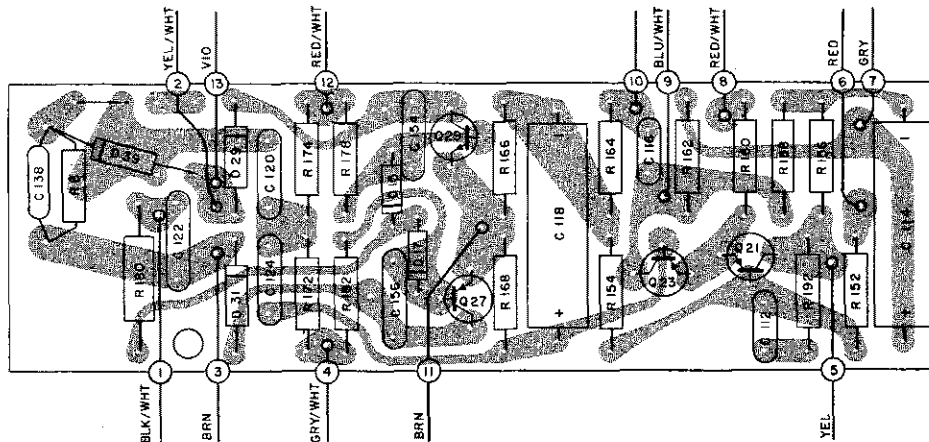

RIGHT CHANNEL POWER OUTPUT SECTION PRINTED CIRCUIT BOARD

043-910

LEFT CHANNEL POWER OUTPUT PRINTED CIRCUIT BOARD
043-910

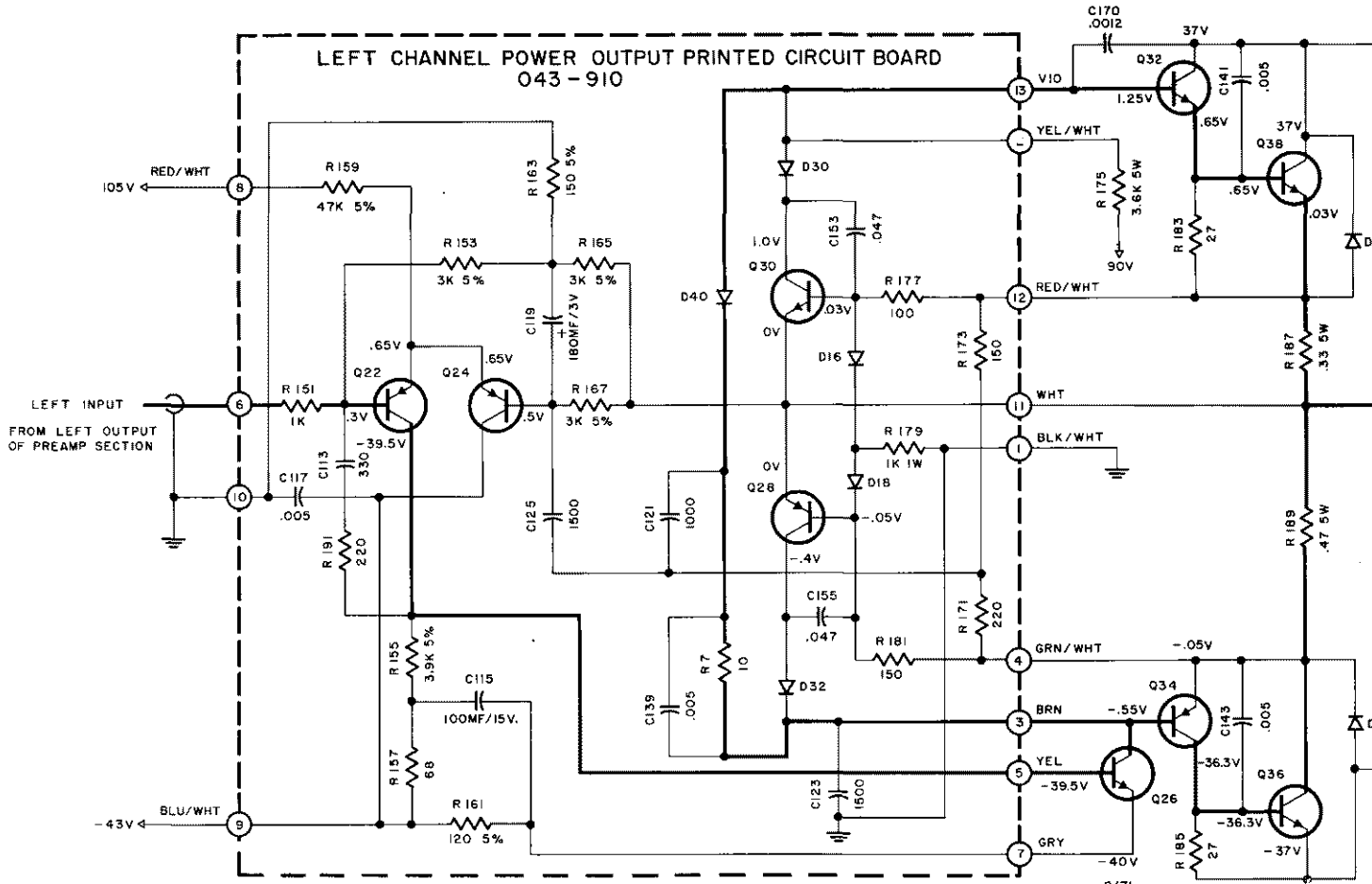

RIGHT CHANNEL POWER OUTPUT PRINTED CIRCUIT BOARD
043-910

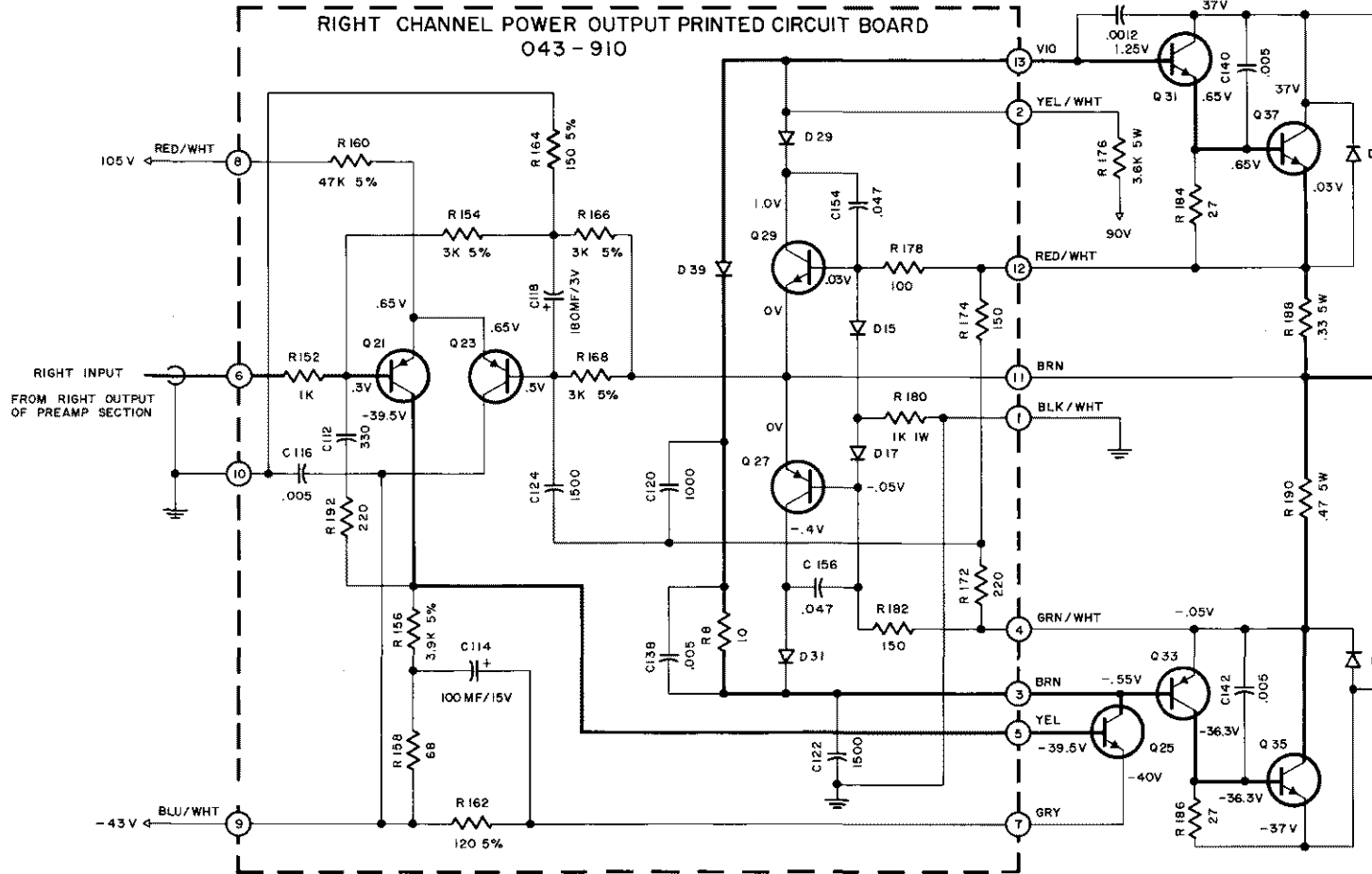

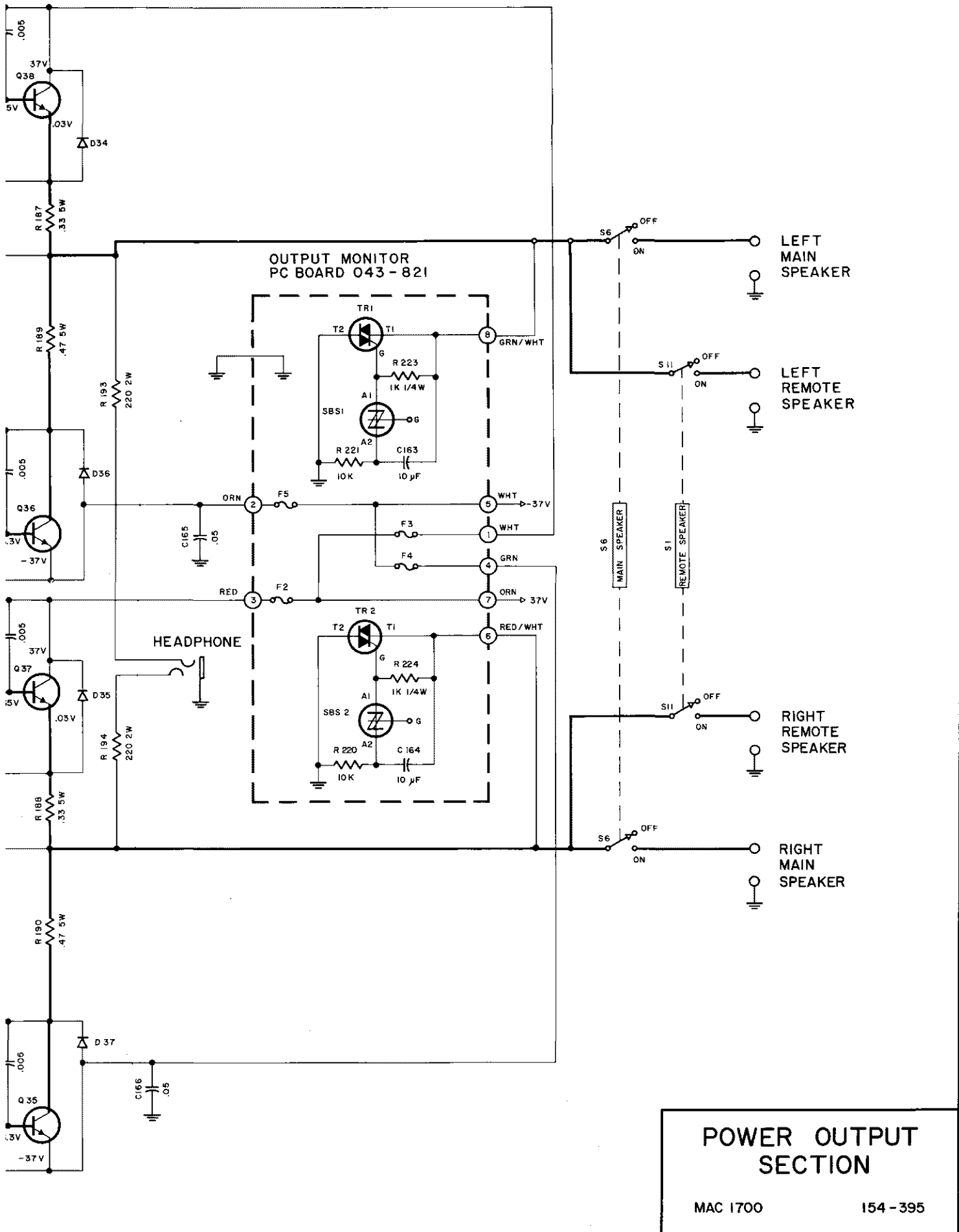

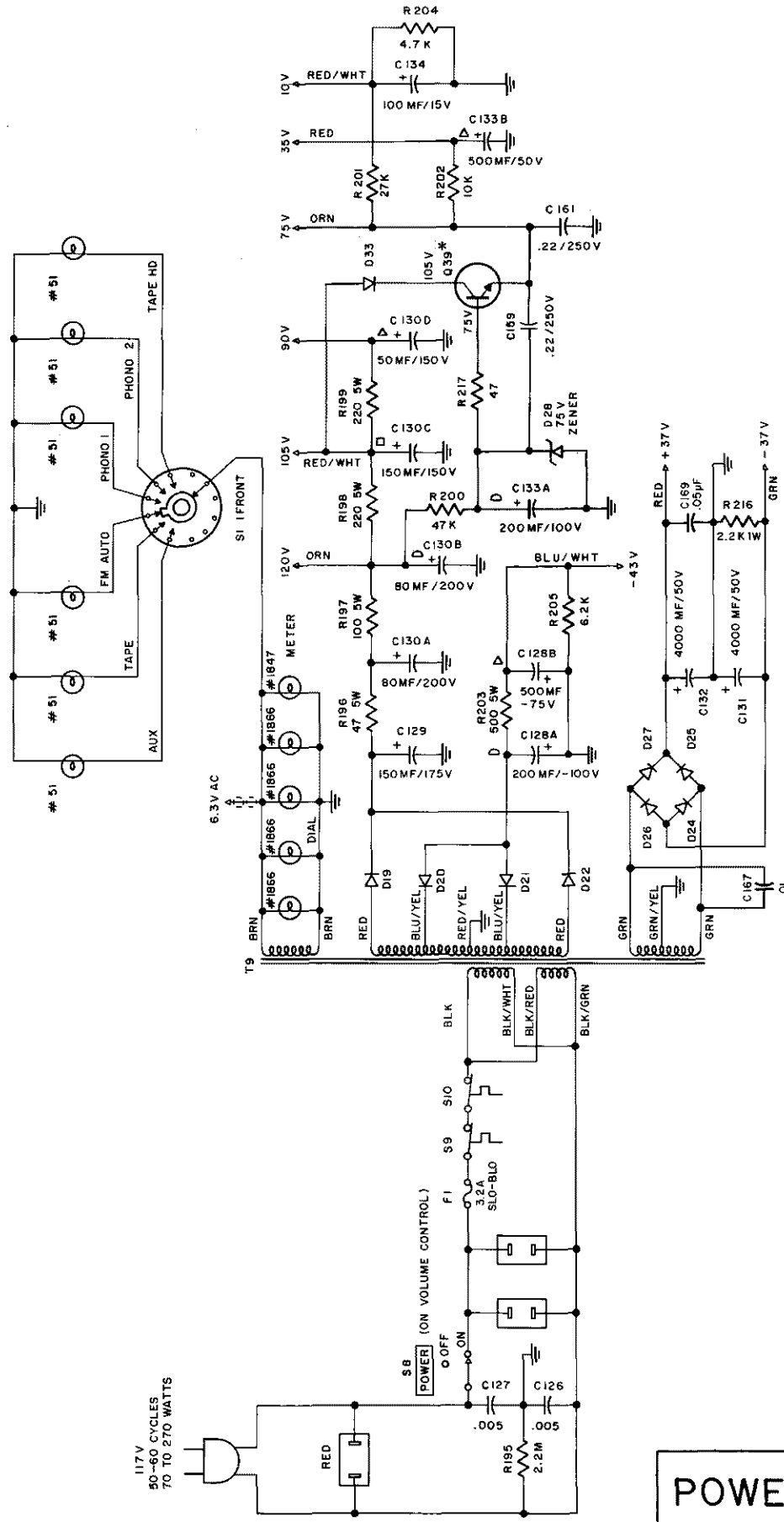

* Q39 IS MOUNTED ON TOP OF THE CHASSIS BETWEEN THE TWO PREAMPLIFIER PRINTED CIRCUIT BOARDS.

POWER SUPPLY SECTION

SCHEMATIC NOTES

1. Printed circuit board components are outlined on the schematics by dotted lines. The circled numbers on the dotted lines correspond to the numbers on the printed circuit board layouts.
2. The heavy lines on the schematics denote the primary signal path.
3. The terminal numbering of rotary switches is for reference only.
4. Unless otherwise specified: Resistance values are in ohms, 1/2 watts, and 10% tolerance; capacitance values smaller than 1 are in microfarads (μF); capacitance values greater than 1 are in picofarads (pF); inductors are in microhenries (μH).
5. All voltages indicated on the schematics are measured under the following conditions:

Use of an 11 megohm input impedance VTVM voltmeter.

All voltages $\pm 10\%$ with respect to ground.

No signal at antenna or other input terminals.

AC input at 117 volts, 50/60 cycles.

Front panel controls at:

Mode Selector	stereo	Muting	out
Input Selector	aux	Filter	out
Volume Control	max	Loudness	out
Balance Control	zero	Tape Monitor	out
Tone Control	flat	Tuning Indicator:	
		100MHz (no signal)	

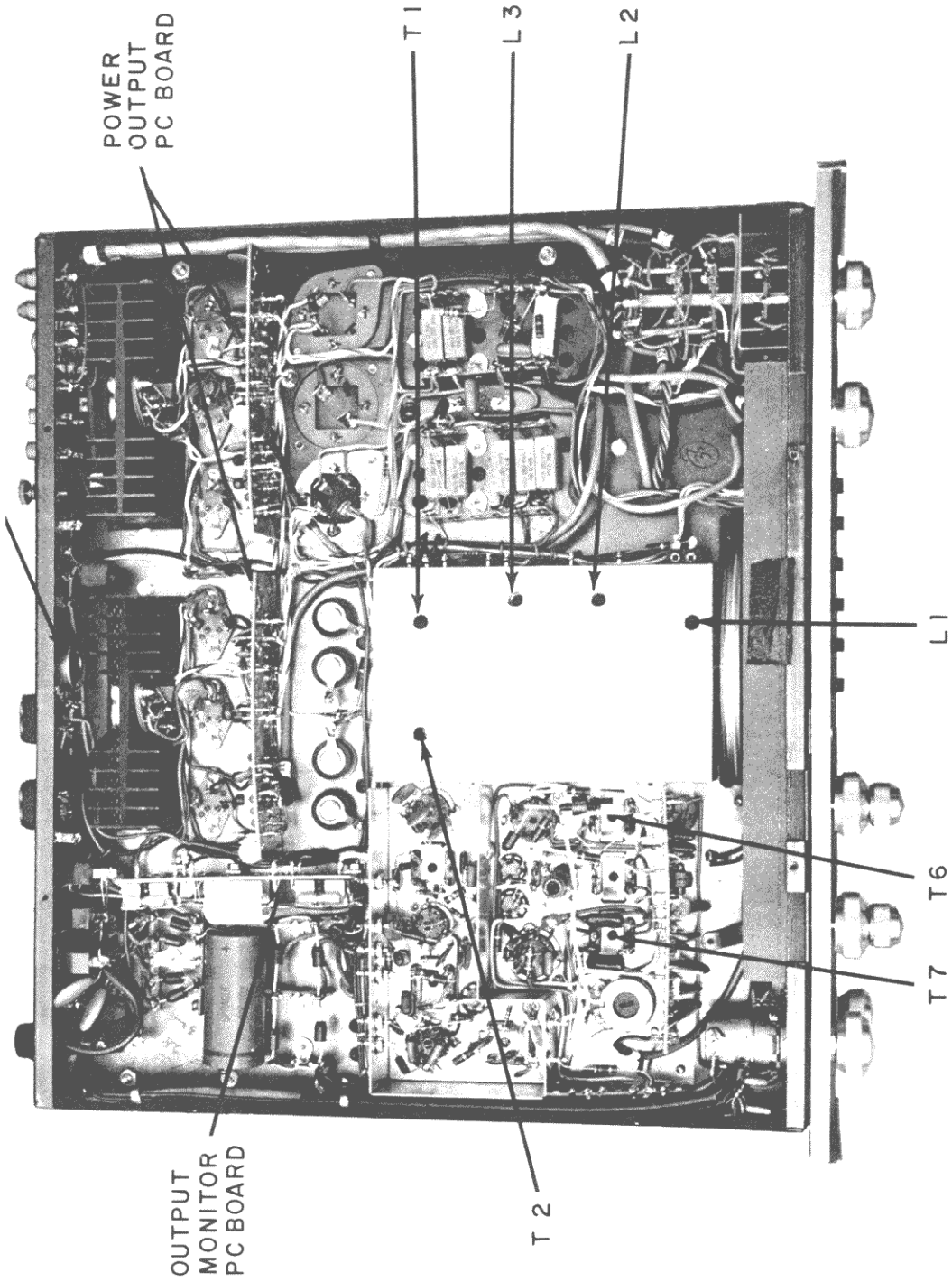

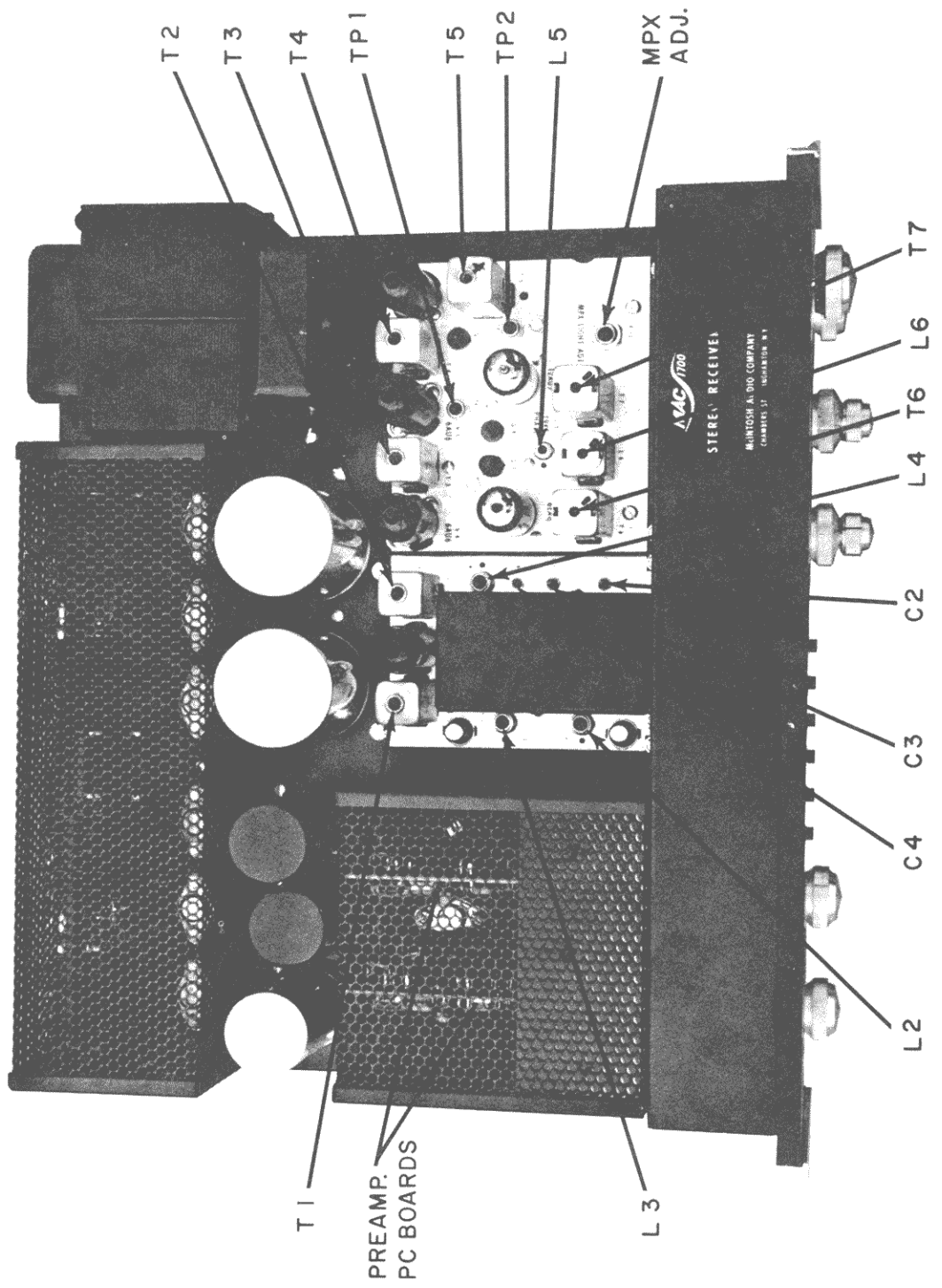

MAC 1700 ALIGNMENT INSTRUCTIONS

TEST EQUIPMENT REQUIRED

All McIntosh tuners are carefully aligned and tested at the factory using the finest available test equipment. All McIntosh tuners will meet their published specifications when shipped from the factory.

After extensive operation, or servicing, it may be desirable to realign the tuner circuits for best performance. The charts below give complete information on the circuit realignment procedure for the MAC 1700.

The test equipment listed (or its equivalent) is necessary to properly align a MAC 1700. The accuracy of the alignment will be directly related to the accuracy and calibration of the test equipment used.

If the necessary test equipment is not available, alignment should not be attempted. For additional information, contact Customer Service Department, McIntosh Laboratory Inc., 2 Chambers Street, Binghamton, New York 13903 (telephone 607-723-3512).

1. FM Signal Generator (Measurements 88 or equivalent)
2. VTVM
3. Multiplex Generator (RCA WR-51A or equivalent)
4. 10.7MHz Generator (preferably crystal controlled)
5. Oscilloscope (Hewlett-Packard 120B or equivalent)
6. Harmonic Distortion Analyzer, desirable but not essential (Hewlett-Packard 333A or equivalent)

FM ALIGNMENT

STEP	TUNE DIAL SETTING	SIGNAL GENERATOR			INDICATOR		ADJUST	TEST LIMITS	REMARKS
		FREQ.	COUPLING	MODULATION	TYPE	CONNECTED TO			
1									
2	Point of no interference or signal	10.7MHz	Through external .01µF capacitor to feedthrough C18	CW	VTVM	TP#1	Maximum possible negative voltage	MPX light should be off for all mono alignment. If it is on with a mono signal, adjust T2 (MPX light adjust control) to cause the light to be off.	
3	Same	Same	Same	Same	VTVM	Junction of C43-R34 (pin 2 of T4)	Same	Shunt to ground the winding not being adjusted with a .01µF capacitor in series with a 1K ohm resistor. As the voltage at TP#1 increases, reduce signal generator output to keep voltage at TP#1 at a low level (less than 2 volts).	
4	Same	Same	Same	Same	VTVM	Pin 6 of T5	Same	If no voltage is present, turn R1 (mute adjust pot) clockwise until a voltage is obtained, then adjust T4	
5	Same	Same	Same	Same	Same	TP#2	Adjust for zero volts	If a distortion analyzer is available, omit this step at this time. Adjust T5 primary after step 9. At that time, use a strong signal from an FM generator, modulate 100% @ 400Hz. Adjust primary of T5 for minimum distortion. Should be less than 0.5%.	
6	10.5MHz	10.5MHz	300 ohm antenna terminals w/ matching network	100% @ 400Hz	VTVM	Oscillator connected to TP#1 and oscilloscope connected to L or R tape output	Maximum negative voltage at TP#1	As TP#1 voltage increases, reduce output if signal generator to keep TP#1 voltage at a low level (less than 2 volts)	

7	90MHz	Same	Same	Same	Same	Oscillator coil L4	Same	Repeat steps 6 and 7 until dial calibration is accurate.
8	105MHz	Same	Same	Same	Same	Mixer trimmer (C3) & RF trimmer (C2)	Same	
9	90MHz	Same	Same	Same	Same	Mixer coil (L3) & RF coil (L2) & antenna coil (L1)	Same	Repeat steps 8 and 9 until the voltage at TP#1 is as high as possible with the lowest possible input signal.
10	Point of no interference			Oscilloscope	L or R tape output	Muting adjust control (R1)		Slide muting switch into "in" position. Adjust muting control until background noise just disappears.
11	105 & 90 MHz	Same	100% @ 400Hz	VWVM connected to L or R tape output		Connect distortion analyzer to L or R tape output and reduce signal at antenna for 30dB total harmonic distortion and noise. The input signal required is IHFM usable sensitivity of the tuner (2.5 μV).		Step 11 is an overall sensitivity check, and requires a distortion analyzer and FM signal generator with attenuator.

MULTIPLY DECODER ALIGNMENT

STEP	TUNER DIAL SETTING	SIGNAL GENERATOR			INDICATOR		ADJUST	TEST LIMITS	REMARKS
		FREQ.	COUPLING	MODULATION	TYPE	CONNECTED TO			
12	100MHz		300 ohm antenna terminals w/ approx. 1000 μ V signal	100% @ 1kHz and 67kHz	Audio VTVM	L or R tape output		Before alignment, turn R 2 (the MPX light adjust control) to cause the MPX light to be on at all times	
13	100MHz		Same	19kHz pilot only	VTVM	Pin 7 of V8	Adjust for minimum voltage output	Set level at 1kHz modulation; then adjust SCA adjustment for minimum audio output with 67kHz modulation	
14	Same		Same	100% @ 1kHz L or R only Pilot on	Audio VTVM	Pin 1 or 2 of 38kHz transformer (T7)	Adjust for maximum negative DC voltage		
15	Same		Same	Same	Oscilloscope	L or R tape output	Adjust for stable scope display	1. Turn off 19kHz pilot MPX generator 2. Adjust top core of 38kHz transformer (T7) to obtain a stable and uniform 1kHz signal scope display. This adjust may be critical so turn core very slowly. 3. Turn 19kHz pilot back on.	
16	Same		Same	Same	Audio VTVM and Oscilloscope	L or R tape output	30dB or more separation	Modulate left channel and measure right channel output. Adjust 19kHz phase coil (L5) for minimum right channel output (maximum separation) Remove all testleads from TP#2 for separation checks.	
17	Same		Same	Turn off 1kHz modulation	Same	Same	Same	Modulate right channel and measure left channel output. Separation in steps 17 and 18 should be at least 30dB.	
18	Same		Same	None- Pilot must be off.	MPX stereo indicator light on the tuner	MPX light adjust control (R2)		Turn R2 until light just goes off. Then, advance about 1/8 of a turn more. Light should operate only on an MPX signal.	
19	Same		Same						
20	Same		Same						

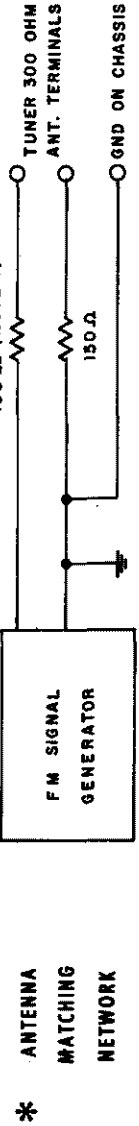

Note 1:
If signal generator has other than 50 ohm internal impedance, use a resistor of 150 ohms less internal generator impedance.

REPLACEMENT PARTS

All parts not listed are common items obtainable from radio parts jobbers.

Replacement parts may be obtained when ordered by PART NUMBER from:

McIntosh Laboratory, Inc.
Customer Service Department
2 Chambers Street
Binghamton, New York 13903
(telephone 607-723-3512)

CAPACITORS

C15	Tubular ceramic	5pF	061-007
C16	Tubular ceramic	5pF	061-007
C36	Mylar	.1 μ F 250V	064-037
C43	Mylar	.1 μ F 250V	064-037
C46	Mylar	.1 μ F 250V	064-037
C47	Mylar	.1 μ F 250V	064-037
C55	Mylar	3300pF 125V	064-074
C62	Elect.	100 μ F 3V	066-047
C63	Mylar	.1 μ F 250V	064-037
C76,77	Mylar	.47 μ F 250V	064-045
C80,81	Elect.	10 μ F 3V	066-110
C86,87	Mylar	.47 μ F 250V	064-045
C90,91	Mylar	.1 μ F 250V	064-037
C92,93	Mylar	.47 μ F 250V	064-045
C94,95	Mylar	.47 μ F 250V	064-045
C96,97	Elect.	10 μ F 3V	066-110
C98,99	Mylar	.47 μ F 250V	064-045
C100,101	Mylar	.047 μ F 250V	064-044
C102,103	Mylar	.01 μ F 250V	064-040
C106,107	Mylar	.047 μ F 250V	064-044
C108,109	Mylar	.047 μ F 250V	064-044
C110,111	Elect.	1.5 μ F 35V	066-092
C114,115	Elect.	100 μ F 15V	066-127
C118,119	Elect.	180 μ F 3V	066-111
C128	Elect.	200/500 μ F -100/-75V	066-093
C129	Elect.	150 μ F 175V	066-102
C130	Elect.	80/80/150/50 μ F 200/200/150/150V	066-103
C131	Elect.	4000 μ F 50V	066-112
C132	Elect.	4000 μ F 50V	066-112
C133	Elect.	200/500 μ F 100/50V	066-099
C134	Elect.	100 μ F 15V	066-127
C136,137	Elect.	10 μ F 50V	066-048
C149,150	Elect.	100 μ F 15V	066-127

C153,154	Mylar	.047 μ F 250V	064-044
C155,156	Mylar	.047 μ F 250V	064-044
C159	Mylar	.22 μ F 250V	064-043
C161	Mylar	.22 μ F 250V	064-043
C163,164	Elect.	10 μ F 25V NP	066-005

DIODES

D1	Si. signal diode	070-022
D2	Si. signal diode	070-022
D3	Si. signal diode	070-022
D4	Si. signal diode	070-022
D5	Si. signal diode	070-022
D6	Si. signal diode	070-022
D7,8	Ge. signal diode	070-003
D9,10	Ge. signal diode	070-003
D15,16	Si. signal diode	070-022
D17,18	Si. signal diode	070-022
D19,20	Si. rectifier	070-031
D21,22	Si. rectifier	070-031
D24,25	Si. rectifier	070-041
D26,27	Si. rectifier	070-041
D28	Zener diode 75V	070-025
D29,30	Si. rectifier	070-030
D31,32	Si. rectifier	070-030
D33	Si. rectifier	070-030
D34,35	Si. rectifier	070-031
D36,37	Si. rectifier	070-031
D38	Si. rectifier	070-030
D39,40	Si. reference diode	070-040

FUSES

F1	Fuse 3.2a Slo-B10	089-006
F2,3	Fuse 4A (SFE-4)	089-021
F4,5	Fuse 4A (SFE-4)	089-021

CHOKES AND COILS

L1	Antenna coil	122-035
L2	RF coil	122-054
L3	Mixer coil	122-062
L4	Oscillator coil	122-056
L5	Filter coil (19kHz phase)	122-008
L6	Filter coil (67kHz trap)	122-009
L7	Choke 2.5 μ H	122-033
L8	Parasitic choke	122-028
L9	Choke 1.2 μ H	122-011

L10	Choke	1.2 μ H	122-011
L12	Choke	1.2 μ H	122-011
L13	Choke	1.2 μ H	122-011
L14	Choke	1.2 μ H	122-011
L15	Choke	1.2 μ H	122-011
L16	Choke	1.2 μ H	122-011
L17	Choke	75 μ H	122-013
L18	Choke	38mH	122-014
L19	Filter coil (lo-pass)		122-015
L20	Filter coil (lo-pass)		122-015

METERS

M1	Tuning meter		124-006
----	--------------	--	---------

TRANSISTORS

Q1	Si. NPN transistor		132-015
Q2	Si. PNP transistor		132-029
Q3	Ge. PNP transistor		132-010
Q4	Si. NPN transistor		132-057
Q5,6	Si. PNP transistor		132-031
Q7,8	Si. PNP transistor		132-031
Q9,10	Si. NPN transistor		132-026
Q11,12	Si. NPN transistor		132-054
Q13,14	Si. NPN transistor		132-041
Q15,16	Si. NPN transistor		132-026
Q17,18	Si. NPN transistor		132-054
Q19,20	Si. PNP transistor		132-029
Q21,22	Si. PNP transistor		132-029
Q23,24	Si. PNP transistor		132-029
Q25,26	Si. NPN transistor		132-515
Q27,28	Si. PNP transistor		132-032
Q29,30	Si. NPN transistor		132-021
Q31,32	Si. NPN transistor		132-521
Q33,34	Si. PNP transistor		132-527
Q35,36	Si. NPN transistor		132-541
Q37,38	Si. NPN transistor		132-541
Q39	Si. NPN transistor		132-516

RESISTORS AND POTENTIOMETERS

R1	Muting adjust		134-036
R2	MPX light adjust		134-036
R3	Balance & loud control		134-214
R4	Treble control		134-183
R5	Bass control		134-184
R6	Volume control		134-190

R175,176	Wirewound 3.6K	10%	5W 139-013
R187,188	Wirewound .33 ohms	10%	5W 139-036
R189,190	Wirewound .47 ohms	10%	5W 139-050
R193,194	Wirewound 220 ohms	10%	2W 139-042
R196	Wirewound 47 ohms	10%	5W 139-045
R197	Wirewound 100 ohms	10%	5W 139-008
R198	Wirewound 220 ohms	10%	5W 139-009
R199	Wirewound 220 ohms	10%	5W 139-009
R203	Wirewound 500 ohms	10%	5W 139-011
R206	Wirewound 500 ohms	10%	5W 139-011

SWITCHES

S1	Input selector switch	146-111
S2	Tape monitor switch	148-022
S3	Mode selector switch	148-022
S4	Filter switch	148-007
S5	Loudness switch	148-007
S6	Speaker switch	148-007
S7	Muting switch	148-003
S9,10	Thermal cut-out	153-007

TRANSFORMERS

T1	First IF	162-005
T2	Second IF	162-004
T3	Third IF	162-004
T4	Muting IF	162-029
T5	Discriminator IF	162-027
T6	Oscillator (38kHz)	162-010
T7	Amplifier (19kHz)	162-009
T9	Power transformer	159-071

TUBES

V1	6DS4 nuvistor	165-013
V2	6DS4 nuvistor	165-013
V3	6HS6	165-060
V4	6HS6	165-060
V5	6AU6-A	165-004
V6	6CS6	165-011
V7	6EA8	165-044
V8	12AU7	165-018

THYRISTORS & TRIGGERS

TR1,2	Triac	131-001
SBS1,2	Bilateral switch	131-002

MODULES

Tone control	130-007
--------------	---------

FRONT PANEL AND TRIM

Front panel	044-039
Dial glass	043-720
Tuning knob	043-479
Volume knob	043-480
Balance knob	090-070
Loudness knob	043-584
Input selector knob	043-480
Treble knob (rear)	090-070
Treble knob (front)	043-584
Bass knob (rear)	090-070
Bass knob (front)	043-584

LAMPS

#1850 (FM/MPX)	058-006
#1847 (meter)	058-008
#1866 (dial glass)	058-014
#51 (selector lights)	058-021
#1828 (tape monitor)	058-027

MISCELLANEOUS ITEMS

Plastic feet	017-041
Tuning shaft	021-052
Shipping carton	043-942
Owners manual	038-210
Mounting template #200	038-180
Shelf template #225	038-184
Dial cord	043-721
Dial pointer	043-586
Shorting plug	127-001
Line cord	170-021
FM dipole antenna	170-033
Fuseholder	178-001
Hardware package	043-582
Push terminal strip	074-030