



For more Hi-Fi manuals and set-up information
please visit www.hifiengine.com



marantz

model 4240

Stereo 2 + Quadradial 4 Receiver

TABLE OF CONTENTS

SECTION	PAGE
Introduction	1
Service Notes	1
AM Tuner	1
FM Tuner	2
Phono and Pre-Amplifier	4
Dolby Unit	5
400Hz Tone	5
Dolby Switch	5
Power Amplifier	6
BTL (Balanced Transformerless) Connection	6
Power Supply Unit	6
Audio Trouble Analysis	7
Test Equipment Required for Servicing	7
AM Alignment Procedure	7
FM Alignment Procedure	8
Audio Adjustment	9
Automatic Voltage Regulator Adjustment	9
Dolby Alignment Procedures	9
Alignment Procedures of Dolby FM Preset Level Controls	10
Explanation of the Dolby Processing Chart	10
Parts List	27
Technical Specifications	42

LIST OF ILLUSTRATIONS

FIGURE	PAGE
1. Main Chassis Component Locations (Bottom View)	12
2. Front Panel Adjustment and Component Locations	12
3. Main Chassis Component Locations (Top View)	13
4. Rear Panel Adjustment and Component Locations	13
5. Dial Stringing	14
6. FM Front End and AM Tuner Assembly P100 Component Locations	15
7. FM IF Amplifier Assembly P200 Component Locations	16
8. MPX Stereo Decoder, Noise and DC Amplifier Assembly P300 Component Locations	16
9. Phono Amplifier Assembly P400 Component Locations	17
10. Vari-Matrix Unit Assembly P500 Component Locations	17
11. Dolby Unit Assembly P600 Component Locations	18
12. Power Amplifier Assembly P700 Component Locations	18
13. Power Supply Assembly P800 Component Locations	19
14. FM De-emphasis Switch Unit Assembly PC01 Component Locations	19
15. Buffer Amplifier Assembly PD01 Component Locations	20
16. Tone Amplifier Assembly PE01 Component Locations	20
17. Tone Control Unit Assembly PF01 Component Locations	21
18. Balance Control Unit Assembly PG01 Component Locations	21
19. 400Hz Oscillator and Meter Driver Assembly PL01 Component Locations	21
20. Loudness, Hi Filter, Speaker and Power Switch Unit Assembly PS01 Component Locations	22
21. Tape Monitor Switch Unit Assembly PT01 Component Locations	22
22. Indicator Lamps Assembly PY01 Component Locations	22
23. Dial Lamps Assembly PZ01 Component Locations	22
24. Schematic Diagram	23, 24
25. Exploded Mechanical Diagram	25, 26

TABLE	PAGE
1. Test Equipment Required for Servicing	7
2. Dolby Processing Chart	11

marantz® SERVICE BULLETIN <small>SS-MAR0234</small>	model number 4240	bulletin number M-4240-3
	for serial numbers SEE BELOW	
	subject DELETION OF FM DE-EMPHASIS SWITCH	
	engineering approval <i>D. Williams</i> 7-3-76	date 5/19/76

The rear panel FM de-emphasis switch (SC01), part number SS0-2020-170, will no longer be incorporated in the Marantz Model 4240. A bracket, part number 288-6160-130, has been added to replace the deleted switch.

The schematic below reflects the changes in PC01:

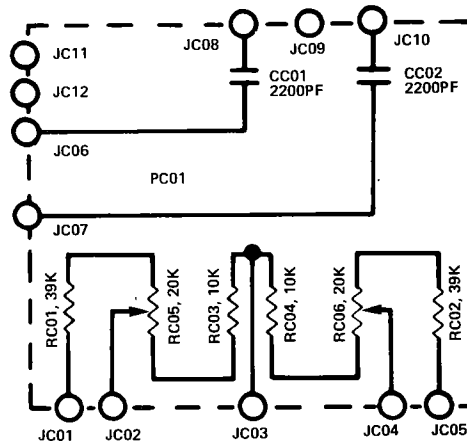

The FM equalization turnover will now change from 75 u sec to 25 u sec when the front panel Dolby switch (S003) is in the FM Dolby mode.

The effective serial numbers showing a deleted FM de-emphasis switch are shown below:

USA	12701
CANADA	61001
EUROPE	54901
AUSTRALIA	500001
DEMKO, SEMKO	200001
PX	80901
HONG KONG	500001

Albert Almeida, Manager
 Technical Services



marantz® SERVICE BULLETIN SS-MAR0234	model number 4240	bulletin number M-4240-4
	for serial numbers WHERE APPLICABLE	
	subject UPDATE OF P300 CIRCUIT BOARD ASSEMBLY	
	engineering approval 12-14-76 JVL	date 11-15-76

Should you receive a Marantz Model 4240 requiring repair of the multiplex/muting circuit, it should be noted that there have been production changes in the MPX Decoder PCB Assembly (P300) for improved reliability.

Incorporate the following changes in the service manual to ensure proper reference information.

1. Resistor R334 has been removed.
2. Resistor R336 has been relocated to the foil side of the circuit board.
3. Diode H314 has been replaced by a jumper wire.
4. Resistor R343 has been changed to 100 ohms.

 Albert Almeida, Manager
 Technical Services

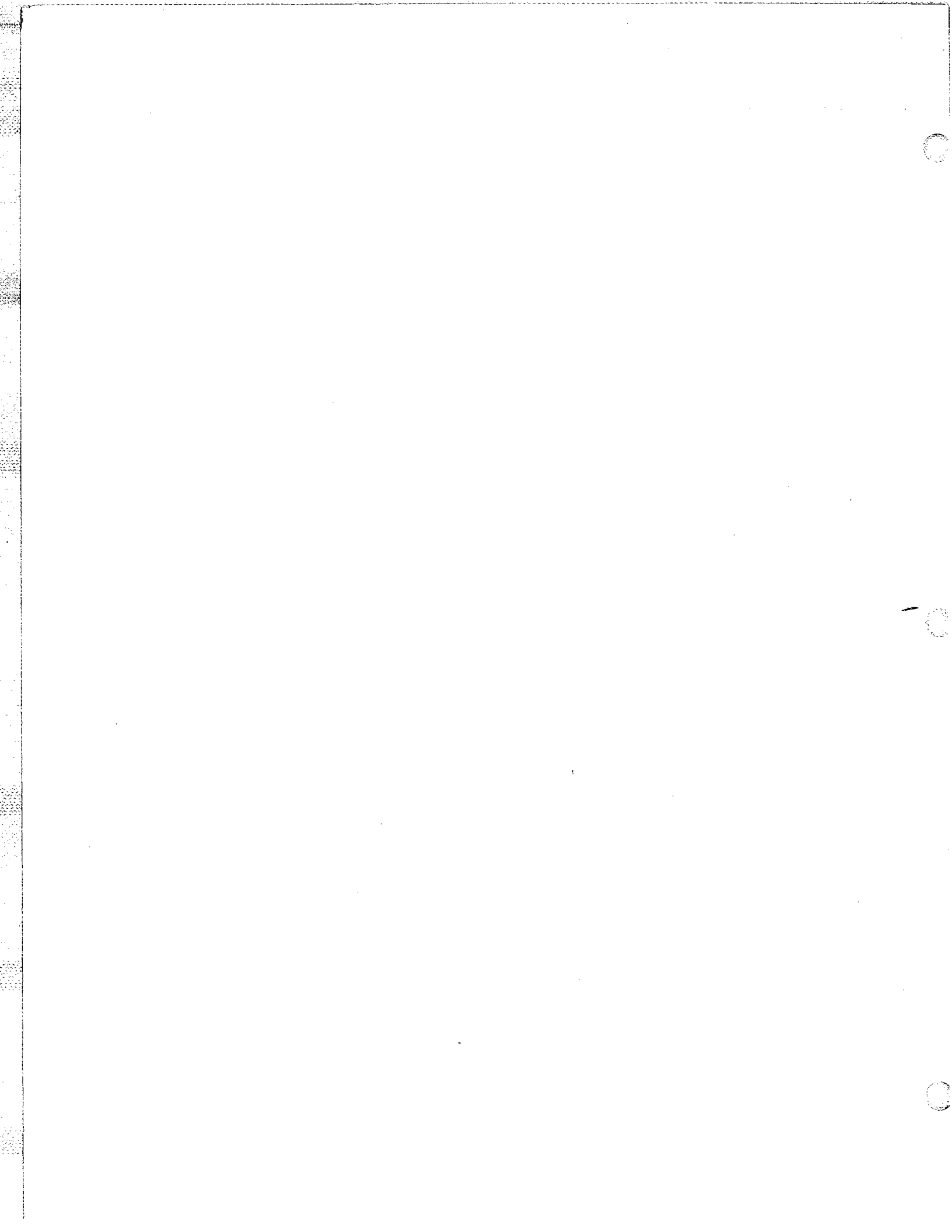

marantz SERVICE BULLETIN	model number	4240 (USA)	bulletin number
	for serial numbers	1001 to 5600	M-4240-1
	subject	DOLBY FREQUENCY RESPONSE	
engineering approval	<i>[Signature]</i>		date
			11-6-73

You may receive customer complaints regarding loss of high frequencies in the overall response of the Dolby circuits for intermediary settings of the DOLBY RECORD LEVEL and PLAY CAL controls.

Perform the following modification in the Dolby unit PCB (P600):

Remove capacitors C615 and C616.

Replace resistors R607 and R608 with resistors of 1K ohms, $\pm 10\%$, $\frac{1}{4}W$.

Perform the following modification in the FM de-emphasis switch PCB (PC01):

Replace resistors RC01 and RC02 with resistors of 68K ohms, $\pm 5\%$, $\frac{1}{4}W$.

NOTE: In some units resistors RC01 and RC02 use combined resistors for specific value. These resistors may be located in both sides of the PCB. All such resistors must be removed when performing the above modification.

After the above modification is completed perform the following test in the numbered sequence listed below:

1. Set Dolby switch to REC 1 and depress the 400Hz TONE push-button on the front panel.
2. Adjust RL11 located on the 400Hz oscillator and meter PCB (PL01) to obtain 580mV RMS at the FRONT TAPE OUTPUT jacks.

cont ...

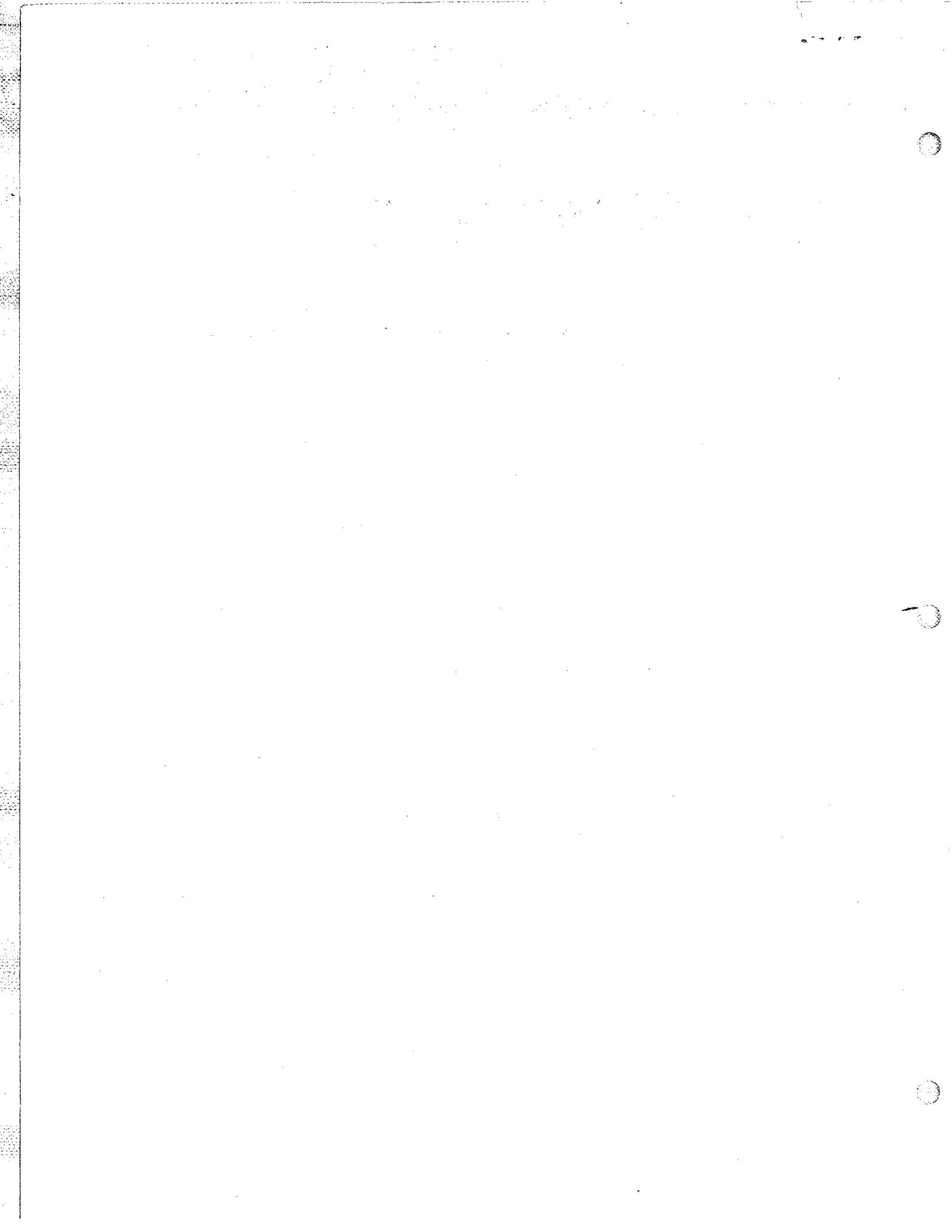

3. Set selector switch to FM mode.
Set Dolby switch to FM Dolby mode.
Release 400Hz TONE SWITCH.
Feed an FM RF signal modulated 50% (37.5 kHz deviation) with 400Hz audio to the antenna terminals and tune the receiver to this frequency.
4. Adjust FM PRESET Dolby level controls (R005 and R006) located on the rear panel, to obtain 580mV (RMS) output at the FRONT TAPE OUTPUT jacks.
5. Set Dolby switch to REC 1 mode.
Set SELECTOR switch to CD4/Aux. mode.
Feed 1kHz audio signal 580mV RMS to the FRONT RIGHT and FRONT LEFT AUX input jacks.
Adjust DOLBY REC LEVEL controls (located on the front panel) to obtain 580mV RMS output at the FRONT RIGHT and FRONT LEFT TAPE OUTPUT jacks.
6. Switch the input audio signal generator to 10kHz, verify the output at TAPE OUT. It should be within $\pm .5$ dB of 580mV, that is, TAPE OUT level at 10kHz should be from 545 to 614mV.

This modification has been incorporated in units, S/N 5601 and later.



Hector E. Gervasio, Manager
Technical Services

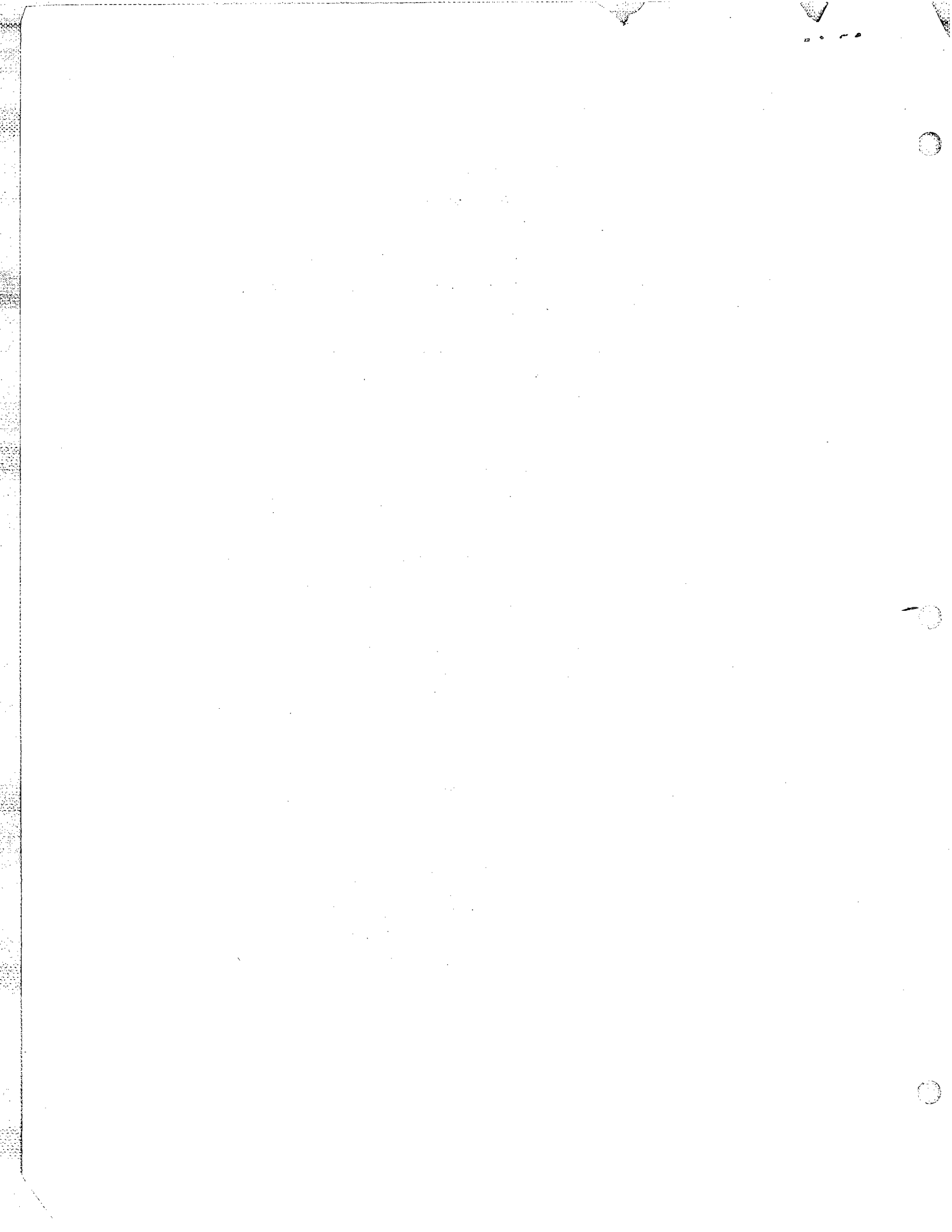

INTRODUCTION

This service manual was prepared for use by Authorized Warranty Stations and contains service information for Marantz Model 4240 Stereo 2+Quadradial 4 Receiver.

Servicing information and voltage data included in this manual are intended for use by the knowledgeable and experienced technician only. All instruction should be read carefully. No attempt should be made to proceed without a good understanding of the operation in the receiver.

The parts list furnish information by which replacement part may be ordered from the Marantz Company. A simple description is included for parts which can be usually be obtained through local suppliers.

1. SERVICE NOTES

As can be seen from the circuit diagram, the chassis of Model 4240 consists of following units. Each unit mounted on a printed circuit board is described within the square enclosed by a bold dotted line on the circuit diagram.

- | | |
|---|-----------------------------|
| 1. FM Front End and AM Tuner | mounted on P.W. Board, P100 |
| 2. FM IF Amplifier | mounted on P.W. Board, P200 |
| 3. MPX Stereo Decoder, Noise and DC Amplifier | mounted on P.W. Board, P300 |
| 4. Phono Amplifier | mounted on P.W. Board, P400 |
| 5. Vari-Matrix Unit | mounted on P.W. Board, P500 |
| 6. Dolby Unit | mounted on P.W. Board, P600 |
| 7. Power Amplifier | mounted on P.W. Board, P700 |
| 8. Power Supply | mounted on P.W. Board, P800 |
| 9. FM De-emphasis Switch Unit | mounted on P.W. Board, PC01 |
| 10. Buffer Amplifier | mounted on P.W. Board, PD01 |
| 11. Tone Amplifier | mounted on P.W. Board, PE01 |
| 12. Tone Control Unit | mounted on P.W. Board, PF01 |
| 13. Balance Control Unit | mounted on P.W. Board, PG01 |
| 14. 400Hz Oscillator and Meter Driver | mounted on P.W. Board, PL01 |
| 15. Loudness, Hi Filter, Speaker, and Power Switch Unit | mounted on P.W. Board, PS01 |
| 16. Tape Monitor Switch Unit | mounted on P.W. Board, PT01 |
| 17. Indicator Lamps | mounted on P.W. Board, PY01 |
| 18. Dial Lamps | mounted on P.W. Board, PZ01 |

2. AM TUNER

All components except ferrite bar antenna are mounted on a printed circuit board P100.

The AM signals induced in a ferrite bar antenna are applied to the RF amplifier section of the AM tuner IC H104 through a capacitor of C129 and amplified to the level required for overcoming the conversion noises, thus giving good S/N performance. The tuned circuits inserted in both out and input circuit of the RF amplifier assure very high image and spurious rejection performance. Thus amplified and selected AM signals are then applied to the converter section through a coupling capacitor C132. While the local oscillator voltage is injected through a capacitor C131, both AM signals and oscillating voltage are mixed and converted into 455KHz intermediate frequency. The resulting IF signal is applied to the first IF transformer L110 consisting of one ceramic filter and two tuned circuits.

The output of L110 is led to the IF amplifier/detector section of H104. The detected audio signal is obtained from PIN ⑪ of H104 and applied to the function switch through the emitter follower by H105.

2.1 Suggestions for AM Tuner Trouble Shooting

Check for broken AM bar antenna, next connect an oscilloscope to the pin ⑪ of H104 or J112 and check for audio signals with the tuning meter deflected. If detected audio signal is

obtained at pin ⑪ of H104, no failure may exist in the AM tuner IC H104 and its associated circuit. If no audio signal is obtained at pin ⑪ of H104, check all voltage distribution in the AM circuits by using a DC VTVM.

3. FM TUNER

The FM Tuner section of Model 4240 is divided into four functional blocks: FM Front End, IF Amplifier and Detector, Muting Control and MPX Stereo Decoding Circuit. FM signals induced by an FM antenna are led to FM antenna coil L101 through a balun coil. These signals are then applied to the FET RF amplifier which in turn applies its output to the mixer transistor H102 through the double tuned high selective circuits. The Mixer convert its input signal into 10.7MHz intermediate frequency and amplifies it at the same time. The H103 is a local oscillator and its output is injected into the base of H102. The 10.7MHz front end output is led to the next IF amplifier unit through a coaxial cable.

The IF amplifier unit consists of five stages of IF amplifier. Three pieces of dual elements ceramic filters are used to obtain high selectivity and four stages of symmetrical diode limiters are also employed for the best limiting characteristics, improved capture ratio and good AM suppression.

A part of H201 output is rectified into DC and fed back to the gate of FET RF amplifier to decrease the gain with increased signal strength.

The IF signal sufficiently amplified through every stage of IF amplifier is finally applied to the transistor limiter. The detected audio output is led to the buffer amplifier H207 and its buffered output is led to; (a) noise amplifier H301 through resistor R301 and capacitor C301, (b) QUADRADIAL jack on the rear panel through resistor R322, (c) MPX stereo decoding circuit through R324.

3.1 Audio Muting and Stereo Mode Auto-Selecting Circuit

The muting circuit consisting of all solid-state electrical switching has been incorporated in the Model 4240. Three inputs control the muting function. The first is related to signal strength, the second to the noise condition at the detector and the third is derived from the DC component of the detector output. These inputs are properly matrixed and gated to provide muting free from noise and transients.

The first input of DC voltage obtained by rectifying a part of IF output signals from H204 and H205 is applied to the base of H308 and turns on it, if the IF output is greater than predetermined level (muting threshold level). When the H308 is turned on the H309 is turned off, allowing the emitter-collector resistance increasing and the collector voltage rises about 9V. The increased collector voltage increases the gate bias voltage and turns on the switching FET H311, decreasing the source-drain resistance to near zero ohm and allowing the audio signal applied to the source to flow to pin ① of the MPX decoding IC H303 through the source-drain path.

When the input signal is lower than predetermined level, the DC output obtained is small and can not turn on the H308, thus the H308 keeps its turn-off state and this makes H309 turn on, decreasing the collector voltage and turning off H311. Thus no audio signals can pass through the FET. This is the fundamental principle of the muting operation but for more elaborate muting operation the second and the third inputs are necessary.

The second input is used to protect the muting operation and MPX stereo beacon lamps from misoperation due to undesirable noises. The high frequency noises included in the detected audio signals are separated by a small capacitor C301 and amplified by the noise amplifier transistor H301 and its output is rectified by two diodes. The rectified DC output is proportional to the noise components in the audio signals.

When there are excessive noises in the audio signals such as obtained with a station incorrectly tuned in, the rectified DC output turns on the transistor H302, decreasing the emitter-collector resistance to zero. This means the collector of H309 is short-circuited to the ground, therefore the H311 is turned off and any audio signals having excessive high frequency noises can not go through the FET's source-drain path.

The transistor H310 connected between pin ⑮ of H303 and the ground is also turned off (when the transistor H302 or H309 is turned on.) and no current flows from pin ⑮ of H303, resulting in turning off the stereo beacon lamps. Thus misoperation due to undesirable noises is also avoided.

The third input is obtained from the FM discriminator circuit. The DC output so called "S" curve is applied to the gate of H304 through a resistor R249 and dividing network (R325 & R326). The DC output is zero with a station correctly tuned in, but will vary from negative to positive values or vice versa when the tuning point is deviated toward either plus or minus frequency from the correct tuning frequency.

When the DC output is increased to a greater level than that of predetermined, the increased source potential of H304 makes the transistor H307 turn on, and this makes the H308 turn off, ... H309 turn on, ... H311 turn off, ... H310 turn off (this means no 19KHz pilot signal is amplified and no stereo beacon is turned on.). When the DC output is increased to the negative predetermined level, the decreased source potential turns off the H305 which in turn makes the H306 turn on and the H308 turned off. The subsequent changes are exactly the same as that just described above.

Thus when the tuning is shifted-or-deviated to the certain frequencies in which undesirable noisy side-audio signals are produced, both muting and 19KHz switching transistors are operated automatically and open the circuits.

With the station correctly tuned in, the bias current of the FET H304 is adjusted so that both transistor H306 and H307 are not turned on, giving no effect on the transistor H308.

3.2 MPX Stereo Decoding Circuit

A Non-equalized audio signal from the FM detector is applied through the phase adjuster network of C330 and R351 to input terminal pin ① on the MPX decoder IC H303. The MPX decoder IC consists of a stereo decoder and postamplifier for the output. The right and left channel signals decoded by the stereo decoder H303, appear at pin ⑩ (right channel) and pin ⑪ (left channel), respectively. These signals are passed through the low-pass filters and de-emphasis networks to eliminate undesirable residual switching signals and are then delivered to postamplifier input pin ⑤ (right channel) and pin ⑦ (left channel), respectively. The signals amplified in the postamplifiers to the required level (approximately 10dB) are delivered to pin ⑥ (right channel) and pin ⑧ (left channel), and are then passed through C324 and C325 to pin terminals J308 and J309, hence, through the SELECTOR switch to the audio amplifier section. Pin ⑮ on the MPX IC H303 is connected through R309 to the collector of the autostereo switch transistor H310, which turns on or off according to the incoming FM signal strength, thereby automatically switching between the stereophonic and monaural operations. The H310 turns on or off in accordance with whether the FM signal strength is more or less than approximately 25 μ V.

3.3 Suggestion for Trouble Shooting of FM Tuner

3.3.1 Symptom: No FM Reception

First turn on the POWER switch and try to tune FM stations. Rotate the fly-wheel tuning knob slowly and observe the SIGNAL STRENGTH meter. If the SIGNAL STRENGTH meter deflect at several frequencies received, the tuner circuits preceding the discriminator circuit may have no failure. When no reading is obtained in the meter, check FM local oscillator circuit, using an RF VTVM. The normal local oscillator voltage is one or two volts (rms) at the tuning capacitor, depending on the tuning capacitor position. If the local oscillator voltage is normal, next check all voltage distribution in the FM Front End and IF amplifier unit. When SIGNAL STRENGTH meter deflects but no sound is obtained, check audio circuits, using high sensitive oscilloscope.

3.3.2 Symptom: No Stereo Separation

Connect an FM signal generator output modulated by a stereo modulator to the rear FM

ANTENNA terminals, and check the stereo beacon is turned on or not. If not turned on, check for 19KHz pilot signal and 38KHz switching signal, using an oscilloscope.

4. PHONO AND PRE-AMPLIFIER

Signals from the PHONO jacks are applied to the phono-amplifier mounted on P400. The amplified and RIAA equalized phono signals and signals from the tuner section, CD-4/AUX and TAPE MONITOR IN jacks are applied to the SELECTOR switch which, in turn, leads the selected signals to the TAPE MON switch and TAPE MONITOR OUT jacks. Applied to the other section of the TAPE MON. switch are signals from the TAPE MONITOR IN jacks. The TAPE MON. switch selects the signals from the SELECTOR switch or those from the TAPE MONITOR IN jacks and the selected signals go to the DOLBY and MODE switches. Signals are then mode processed by the MODE switch and its associated circuit and applied to the tone control amplifier through the buffer amplifier and BALANCE and VOLUME controls. The bass and treble controlled signals from the tone control amplifier pass through the hi filter before they reach the main amplifier.

4.1 Mode Switch

MODE switch S002 has positions of MONO, 2 CH, DISCRETE, VARI-MATRIX, and SQ DECODER.

In the MONO position, all input signals are mixed together and delivered to all four channels.

In the 2 CH position, each pair of input signals right-front (RF) and right-rear (RR), and left-front (LF) and left-rear (LR) are mixed together. The resultant signals (RF + RR) and (LF + LR) are delivered to the pairs of RF and RR, and LF and LR channels, respectively.

In the DISCRETE position, each channel signal is separately routed to the corresponding channel.

In the VARI-MATRIX position, 2-channel stereo input signals are converted into quadraphonic signals through the vari-matrix circuit; the input right and left channel signals are fed directly to the LF and RF channels, while the signals to the LR and RR channels are synthesized from the 2-channel input signals under the control of the DIMENSION control. The LR and RR channel signal components are controlled by the DIMENSION control as shown below.

DIMENSION Control Setting	LR Output	RR Output
Minimum (FCCW)	LF + RF	RF + LF
Center	LF	RF
Maximum (FCW)	LF - RF	RF - LF

When the DIMENSION control is set to the minimum position the LR and RR channel signals become monophonic, to the center are stereophonic, and to the maximum are out of phase, thus providing vanished sound image positioning.

In the SQ DECODER position, signal sources encoded by the CBS SQ system are ideally decoded into 4-channel signals. Required for this operation is incorporation of the SQ Adaptor, Model SQA-1, into the Model 4240.

4.2 Balance Control

Signals from the buffer amplifiers are fed into the balance control circuit, in which the signals are controlled by three balancers: FRONT L-R, REAR L-R, and FRONT-REAR. By setting the FRONT-REAR balancer to the "FRONT" side and the FRONT L-R balancer to the "L" side, for example, only the front left channel is driven.

The balance control circuit is provided with the REMOTE CONTROL switch which makes the Model RC-4 Remote Control Box operative when set to the "REMOTE" position. In the "REMOTE" position the BALANCE and VOLUME controls on the Model 4240 become

ineffective since signals are led to the Model RC-4. Balance and volume can be adjusted by the Model RC-4.

Balance and volume controlled signals are led to the tone control amplifier.

5. DOLBY UNIT

The Dolby unit built in Model 4240, which is a switchable processor, is inserted in each of both FRONT R and L channels. The attached "DOLBY PROCESSING CHART" will facilitate you to well understand the operation of the Dolby circuit.

An input signal coming to J601 is amplified by H601, and its output signal is led to the filter which cuts off the tape bias. The signal passed through the filter is further amplified and comes to the mixing circuit of resistors R623 and R625 and to the phase inverting circuit of H607 and H609. The output signal is fed out from J607. In the recode mode of operation, the signal is applied from J605 preceding the mixing circuit. The signal is then discriminated in the frequency and level by the dynamic filter consisting of H611, H613, H615 and H617, and is fed back to the mixing circuit. In the playback mode of operation, a part of the output signal (at J607) comes to J611 and is discriminated in the frequency and level by the dynamic filter consisting of H611, H613, H615 and H617 and fed back to the mixing circuit.

6. 400Hz TONE

The 400Hz tone signal is a 580mV, 400Hz sine wave led to the FRONT and REAR TAPE MONITOR OUT jacks at any position of the DOLBY switch (with exception of the RECORD II position) and the SELECTOR switch.

The output signal of the 400Hz oscillator consisting of HL01 and HL02 is fed to JL02 and JL03, respectively, through the emitter follower HL03. The output levels at JL02 and JL03 are adjusted to 580mV and approximately 25mV, respectively.

The signal fed from the Dolby P.W. Board comes to JL04 and is rectified through HL06. The rectified output at JL06 is led to the meter M004.

7. DOLBY SWITCH

This switch sets the Dolby noise-reduction circuit for record or playback and also switches the Meter Mode from AM or FM SIGNAL STRENGTH to DOLBY CAL LEVEL, or vice-versa. With the DOLBY switch placed in "OFF" position, the Meter will be used as a SIGNAL-STRENGTH meter; in all other positions as a DOLBY CAL LEVEL meter.

7.1 Dolby FM

This position is used for listening to Dolbyized FM broadcasts. The Dolby FM level has been pre-adjusted at the factory.

7.2 Play

This position is used to play back a Dolbyized source (except FM).

7.3 Off

With this position, the Dolby circuit is by-passed and the input signals are directly applied to both TAPE MONITOR OUT jacks and amplifiers.

7.4 Record I

For making a Dolbyized recording from an in-coming "flat" (non-Dolbyized) signal. When the MONITOR switch is in the SOURCE (out) position, the "flat" signal will be heard. When the MONITOR switch is in the TAPE (in) position, the Dolbyized signal from the tape will be heard.

7.5 Record II

For making a "flat" (non-Dolbyized) recording from an in-coming Dolbyized signal.

Regardless of the position of the MONITOR switch, a "flat" signal will be heard.

8. RECORD LEVEL (L) (R)

These knobs control the record level of the signals to be recorded through the Dolby unit. Adjust the knobs so that the Level Meter pointers of the tape recorder do not exceed the 0VU level.

9. PLAY CAL. (L) (R)

These knobs adjust the playback outputs from a tape deck to the proper Dolby level.

10. DOLBY FM PRESET LEVEL CONTROLS

These factory-adjusted controls govern FM output level to the Dolby circuit. These controls are for the use of a qualified technician only.

11. 400Hz TONE SWITCH

This is used for calibration of the record input level of the tape deck. When the switch is depressed, the built-in oscillator operates and a sine wave signal output of 580mV will be applied to the four TAPE MONITOR OUT jacks.

12. FM DE-EMPHASIS SWITCH

At present both normal and Dolbyized FM broadcast programs are being transmitted with pre-emphasis time constant of 75 microsecond.

However if the Dolbyized FM broadcasting is approved by F.C.C., this pre-emphasis time constant for Dolbyized FM broadcast will be changed to 25 microsecond. The FM DE-EMPHASIS switch provided on the rear of Model 4240 is used for switching the time constants. After the permission of Dolbyized FM broadcasting, set the switch to 25 μ S position. This automatically change the time constant to 75 μ S while the DOLBY switch is placed in other than DOLBY FM positions (namely normal FM broadcast position), thus, the de-emphasis time constant for each normal and Dolbyized FM reception will be correctly set.

13. POWER AMPLIFIER

A differential amplifier consisting of the transistors H701 and H703 is used to provide satisfactory D.C. stability. The transistor H705 drives the inverter transistors H711 and H713 which, in turn, drive the power stage consisting of H001 and H003. Transistors H707 and H709 are current limiter, operating as a power transistor protection circuit.

Excessive current flow in the power output stage is detected by the resistors R759 and R761 and the resultant variation is applied to the transistors H707 and H709 and make them turned on. This decreases the base biasing current for H711 and H713. In this way the current flow in the power output stage (H001 and H003) is restricted within a safe predetermined value.

14. BTL (Balanced Transformerless) CONNECTION

This power amplifier is designed to operate in either 2-channel or 4-channel modes, depending on the setting of the POWER MODE switch that incorporates phase-conversion and power switch for BTL connection.

With this switch placed in the 17Wx4 position, this unit operates as a 17W 4 channel amplifier. With the switch placed in the 40Wx2 position, the unit operate as a 40W 2 channel amplifier, in this case, the power output is obtained only from FRONT SPK terminals.

15. POWER SUPPLY UNIT

The power supply unit consisting of transistors H801, H802 and H803, which operates as an automatic voltage regulator provides +35V DC to all of the amplifiers except main amplifiers and +14V DC to the tuner section.

16. AUDIO TROUBLE ANALYSIS

1. Excessive line consumption
 - a. Check for shorted rectifiers H007.
 - b. Check for shorted transistors H001 through H004.
 - c. Check L001 for short.
2. No line consumption or zero bias
 - a. Check line cord, fuse, shorted H005 & H006, H718 & H719.
 - b. Check for open rectifiers H007 or open L001.
3. Excessive hum and noise level
 - a. Check filter capacitors C002, C003, C709 & C710.
 - b. Check for shorted transistor H801 and H802.
4. Parasitic oscillation
 - a. Check for defective capacitors, C005, C006, C711, C712, C713, C714, C721, C722, C723 and C724.
5. Improper clipping
 - a. Check for proper adjustment of R715 and R716.

17. TEST EQUIPMENT REQUIRED FOR SERVICING

Table 1 lists the test equipment required for servicing the Model 4240 Receiver.

Item	Manufacturer and Model No.	Use
AM Signal Generator		Signal source for AM alignment.
Test Loop		Used with AM Signal generator.
FM Signal Generator	Less than 0.3% distortion	Signal source for FM alignment.
Stereo Modulator	Less than 0.3% distortion	Stereo separation alignment and trouble shooting.
Audio Oscillator	Weston Model CVO-100P, less than 0.02% residual distortion is required.	Sinewave and squarewave signal source.
Oscilloscope	High sensitivity with DC horizontal and vertical amplifiers.	Waveform analysis and trouble shooting and ASO alignment.
VTVM	With AC, DC, RF range	Voltage measurements.
Circuit Tester		Trouble shooting.
AC Wattmeter	Simpson, Model 380	Monitors primary power to Amplifier.
AC Ammeter	Commercial Grade (1-10A)	Monitors amplifier output under short circuit condition.
Line Voltmeter	Commercial Grade (0-150V AC)	Monitors potential of primary power to amplifier.
Variable Autotransformer (0-140V AC, 10 amps)	Powerstat, Model 116B	Adjusts level of primary power to amplifier.
Shorting Plug	Use phono plug with 600 ohm across center pin and shell.	Shorts amplifier input to eliminate noise pickup.
Output Load (8 ohms, $\pm 1\%$ 100W)	Commercial Grade	Provides 8-ohm load for amplifier output termination.
Output Load (4 ohms, $\pm 1\%$ 100W)	Commercial Grade	Provides 4-ohm load for amplifier output termination.

Table 1. Test Equipment Required for Servicing

18. AM ALIGNMENT PROCEDURE

18.1 AM IF Alignment

1. Connect a sweep generator to the J106 and an alignment scope to the J112.
2. Rotate each core of IF transformer L110 and L111 for maximum height and flat top symmetrical response.

18.2 AM Frequency Range and Tracking Alignment

1. Set AM signal generator to 525KHz. Turn the tuning capacitor fully closed (place the tuning pointer at the low end.) and adjust the oscillator coil L109 for maximum audio output.
2. Set the signal generator to 1650KHz. Place the tuning pointer in the high frequency end and adjust the oscillator trimmer on the oscillator tuning capacitor for maximum audio output.
3. Repeat the step 1 and 2 until no further adjustment is necessary.
4. Set the generator to 600KHz and tune the receiver to the same frequency and adjust a slug core of AM ferrite rod antenna and RF coil L108 for maximum output.
5. Set the generator to 1400KHz and tune the receiver to the same frequency and adjust both trimming capacitors of antenna and RF tuned circuit for maximum output.
6. Repeat the step 4 and 5 until no further adjustment is necessary.

Note: During tracking alignment reduce the signal generator output as necessary to avoid AGC action.

19. FM ALIGNMENT PROCEDURE

1. Connect an FM signal generator to the FM ANTENNA terminals and an oscilloscope and an audio distortion analyzer to the TAPE MONITOR OUT jacks on the rear panel.
2. Set the FM SG to 87.5MHz and provide about 3 to $5\mu\text{V}$. Place the tuning pointer at the low frequency end by rotating the tuning knob and adjust the core of oscillator coil L104 to obtain maximum audio output.
3. Set the FM SG to 108.5MHz and provide about 3 to $5\mu\text{V}$ output. Rotate the tuning knob and place the tuning pointer at the high frequency end and adjust the trimming capacitor C118 for maximum output.
4. Repeat the step 2 and 3 until no further adjustment is necessary.
5. Set the FM SG to 90MHz and tune the receiver to the same frequency. Decrease signal generator output until the audio output level decreases with the decreasing generator output. Adjust the antenna coil L101, RF coil L102 and L103 and IF transformer L105 for minimum audio distortion.
6. Set the FM SG to 106MHz and tune the receiver to the same frequency. Adjust the trimming capacitors of antenna and RF tuning circuits for minimum distortion.
7. Adjust the secondary core (upper) of discriminator transformer L201 so that the center tuning meter pointer indicates its center at no signal applied. Set the FM SG to 98MHz and increase its output level to $1\text{K}\mu\text{V}$ and tune the receiver to the same frequency so that the center tuning meter pointer indicates its center. Adjust the primary core (lower) of L201 for minimum distortion.

19.1 Stereo Separation Alignment

1. Set the FM SG to provide $1\text{K}\mu\text{V}$ at 98MHz. Tune the receiver to the same frequency so that the center tuning meter pointer indicates its center.
2. Modulate the FM SG with stereo composite signal consisting of only subchannel signal (of course a pilot signal must be included). Adjust the core of L303 for maximum audio output, then, modulate the signal generator with a stereo composite signal consisting of only L channel signal and adjust the trimming resistor R351 for maximum and same separation in both channels.

19.2 Muting Circuit Alignment

1. Connect a VTVM across the resistor R327 and adjust the resistor R327 until the meter reads 0.75V DC at no signal.
2. Set the FM SG to provide $1\text{K}\mu\text{V}$ at 98MHz and tune the receiver to the same frequency correctly.
3. Turn on FM MUTING pushswitch. Shift the FM signal generator frequency to plus and minus and note both plus and minus shifted frequencies at which undesirable audio side responses are muted out. Adjust the R327 so that the same shifted frequencies mute the undesirable side response.

20. AUDIO ADJUSTMENT

1. Connect a VTVM to J713(+) and J719(-) and adjust the trimming resistor R735 until the VTVM reads 20mV DC. For the other channel connect the VTVM to J714(+) and J720(-) and adjust the R736 for the same reading.
2. Connect a VTVM to J715(+) and J706(-) and adjust the trimming resistor R715 until the VTVM reads 0V DC. For the other channel connect the VTVM to J716(+) and J706(-) and adjust the R716 until the VTVM reads 0V DC.

21. AUTOMATIC VOLTAGE REGULATOR ADJUSTMENT

Connect a VTVM to J801(+) and J811(-) and adjust R801 until the VTVM reads 35V under no signal condition.

22. DOLBY ALIGNMENT PROCEDURES

Prior to the adjustment, turn the variable resistors PLAY CAL and REC LEVEL all the way to the right and the SELECTOR switch to the CD-4/AUX position. Use the CD-4/AUX and TAPE MONITOR OUT jacks for the input and output signals.

1.
 - 1) Set the DOLBY switch to the RECORD I position.
 - 2) Adjust the semi-fixed resistor R653 for maximum source voltage of the FET H611.
 - 3) Connect J620 and J613 to the ground.
 - 4) Apply a 5KHz sine wave so as to obtain 17.5mV at J605.
 - 5) Record the output level at the TAPE MONITOR OUT jack with the above signal input.
 - 6) Adjust the semi-fixed resistor R659 so that the output level at the TAPE MONITOR OUT jack may increase $10\pm 0.25\text{dB}$ when J620 is disconnected from the ground.
 - 7) Record the above output level.
 - 8) Adjust the semi-fixed resistor R653 so that the output level may decrease $2\pm 0.25\text{dB}$ when J613 is disconnected from the ground.
 - 9) Connect J613 to the ground again, and assure the level increase in the step (6) above. Disconnect J613.
2.
 - 1) Set the DOLBY switch to the RECORD II position.
 - 2) Connect J620 and J613 to the ground.
 - 3) Apply a 5KHz sine wave so as to obtain a 44mV voltage at J605.
 - 4) Check to insure that the level at the TAPE MONITOR OUT jack decreases $10\pm 0.5\text{dB}$ when J620 is disconnected from the ground.
 - 5) Disconnect J620 and J613 from the ground.
 - 6) Check to insure that the output voltage at the TAPE MONITOR OUT jack is 17.5mV ($\pm 0.5\text{dB}$).
3. For the level adjustment, set the DOLBY switch and SELECTOR switch to the RECORD I

and CD-4/AUX positions, respectively, and use the TAPE MONITOR OUT jack for the output signal. By setting the 400Hz TONE pushswitch "in", the 400Hz sine wave is fed out. Adjust the semi-fixed resistor RL11 for 580mV of the sine wave output voltage in both R and L channels. Then, set the DOLBY switch to the RECORD II position, and apply the 400Hz signal for 580mV of the output voltage. Adjust the semi-fixed resistors RL28 and RL29 so that the DOLBY LEVEL meter may point the Dolby level. Change over the METER switch, and perform this adjustment for both R and L channels.

Next adjust the semi-fixed resistor RL12 for 580mV output level when the DOLBY switch is set to the OFF position. Check this output level after the adjustment of the level setting semifixed resistors RL11 and RL12. The output level must be precisely 580mV since it is a reference voltage level in the Dolby circuit.

23. ALIGNMENT PROCEDURES OF DOLBY FM RESET LEVEL CONTROLS

Connect an FM signal generator to the FM antenna. Set the modulation frequency and degree of modulation of the FM signal generator to 400Hz and 50%.

Set the FM signal generator to 98MHz and the DOLBY switch to the OFF position. Turn the Tuning knob on Model 4230 until it tunes to the 98MHz signal from the FM signal generator.

Then, set the DOLBY switch to the DOLBY FM position, and adjust the FM preset level controls RC05 and RC06 so that the DOLBY LEVEL meter may point the Dolby FM level. Change over the METER switch, and perform this adjustment for both R and L channels.

24. EXPLANATION OF THE DOLBY PROCESSING CHART

This chart shows the condition of the signals available at the speakers (SPKRS) and at the TAPE MONITOR OUT terminals as a function of different control settings.

To understand the chart refer to the symbols below:

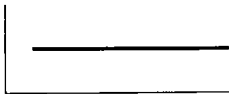
- 

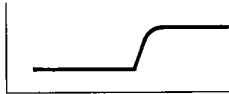
— Represents a signal which has not been applied to either Record or Playback Dolby circuits. The relative amplitudes of all audio frequencies remain unaltered at all levels.
- 

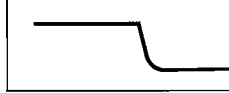
— Represents a signal which has been processed by the Dolby Record circuit. The relative amplitude of the high frequencies is increased at low signal levels.
- 

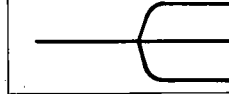
— Represents a signal which has been processed by the Dolby Playback circuit. The relative amplitude of the high frequencies is decreased at low signal levels.
- 

— Represents a signal which has been processed by both the Record and the Playback Dolby circuits.

These circuits are complementary. Therefore, relative amplitudes of all audio frequencies are restored to their original values.

SIGNAL	DOLBY SW ↑	RECORD											
		OFF			I			II					
		DOLBY FM		PLAY		SOURCE		TAPE		SOURCE		TAPE	
FM TRANSMISSION	TAPE MON ↑	SIGNAL AT ↑	SOURCE	TAPE	SPKRS	TAPE OUT	SPKRS	TAPE OUT	SPKRS	TAPE OUT	SPKRS	TAPE OUT	
NORMAL FM													
75 μS FM WITH DOLBY													
DOLBY FM (25 μS W/DOLBY)													
OTHER SOURCE													

NOTE: * DE-EMPHASIS SWITCH IN THE 75 μS POSITION.
 ** DE-EMPHASIS SWITCH IN THE 25 μS POSITION.

Table 2. Dolby Processing Chart

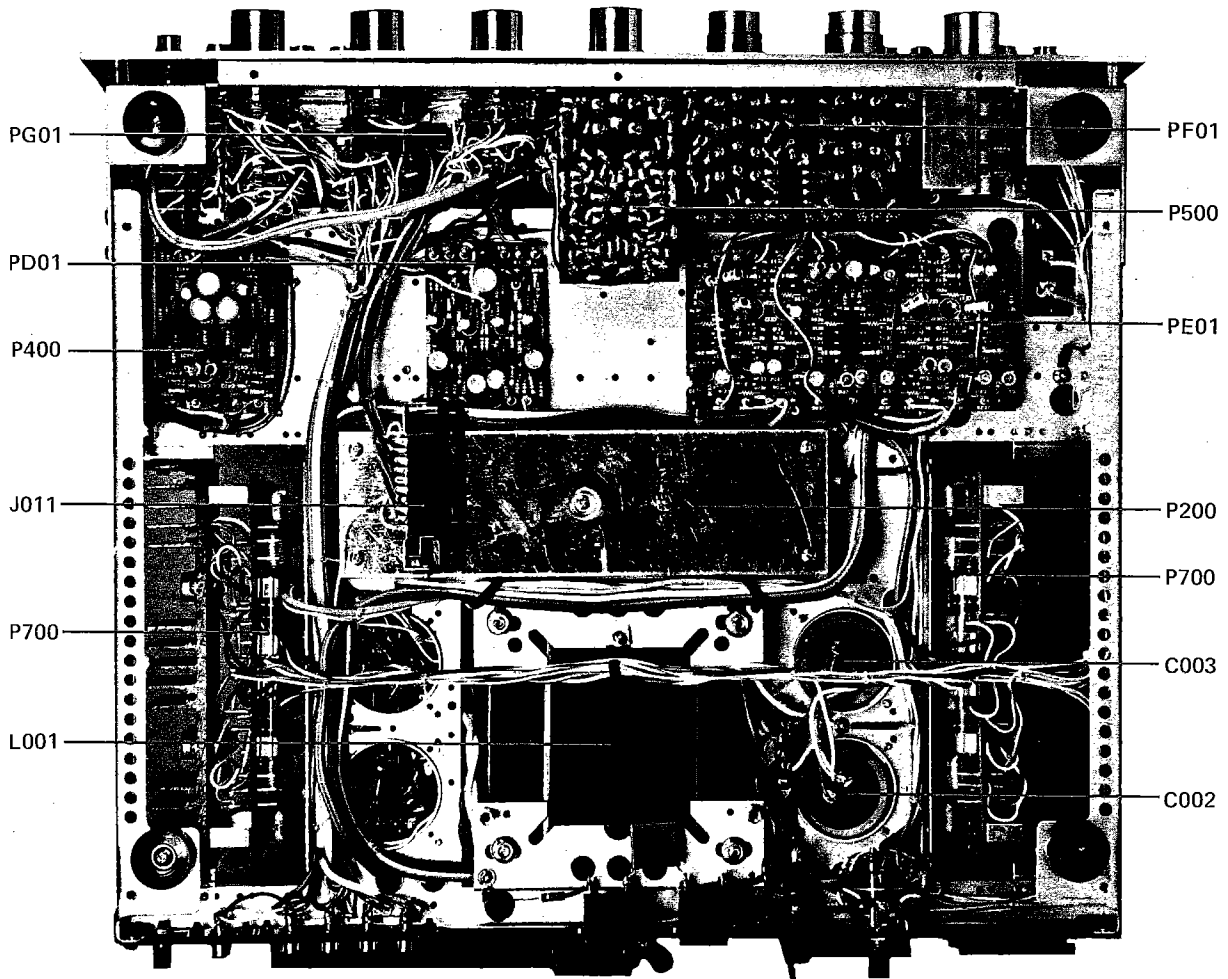

Figure 1. Main Chassis Component Locations (Bottom View)

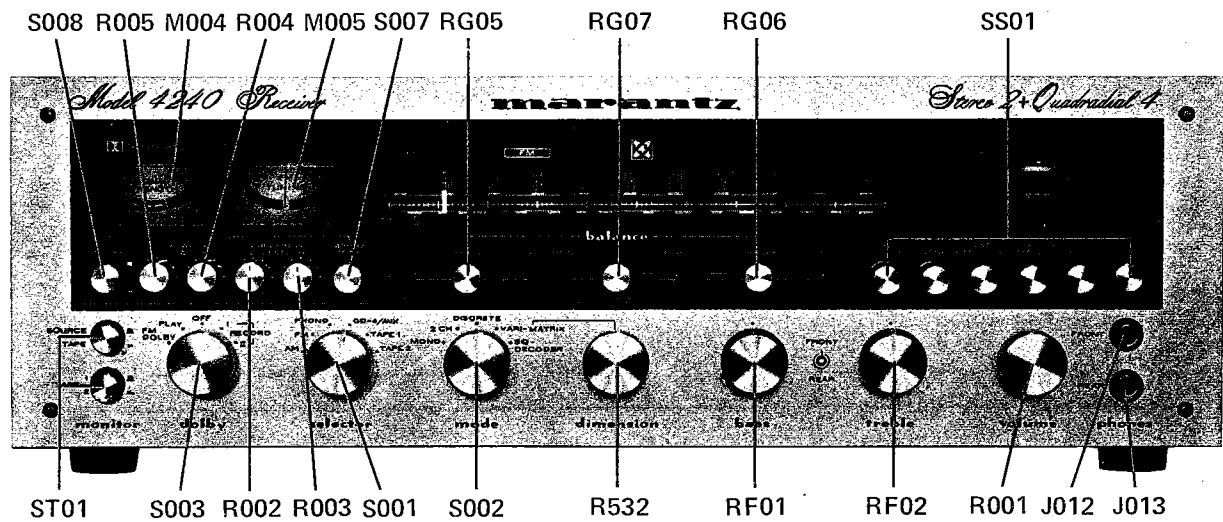

Figure 2. Front Panel Adjustment and Component Locations

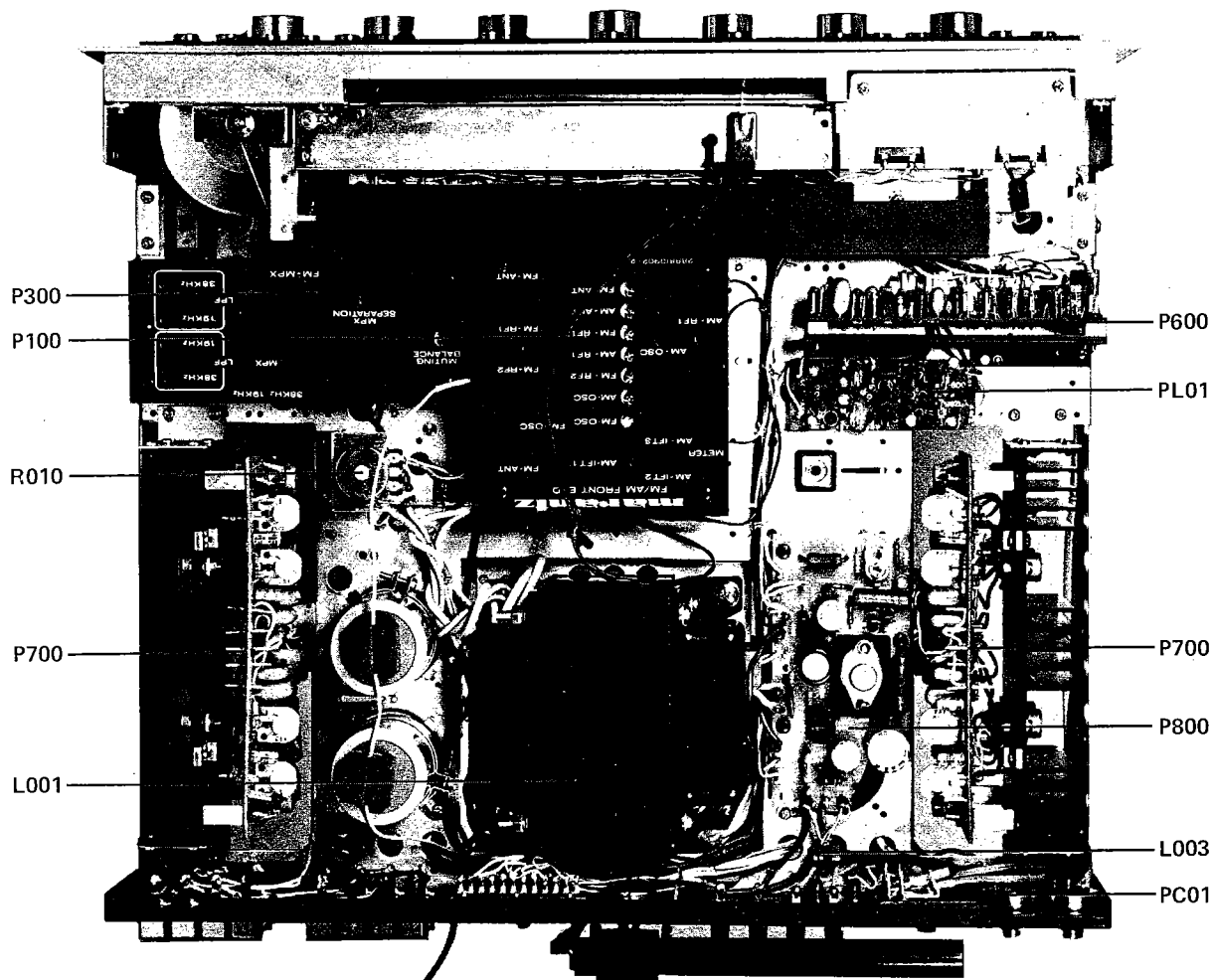

Figure 3. Main Chassis Component Locations (Top View)

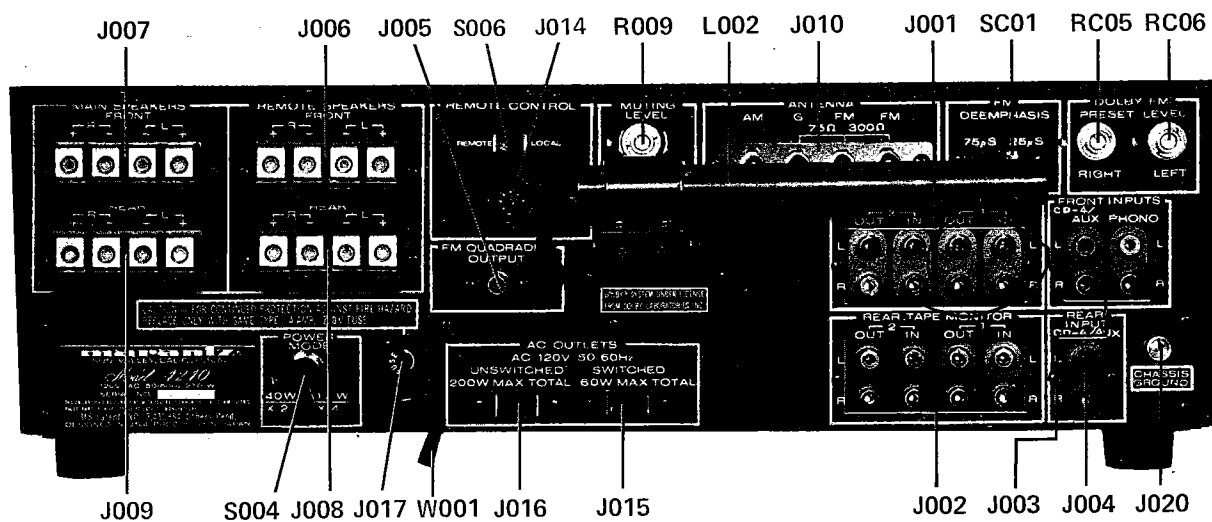

Figure 4. Rear Panel Adjustment and Component Locations

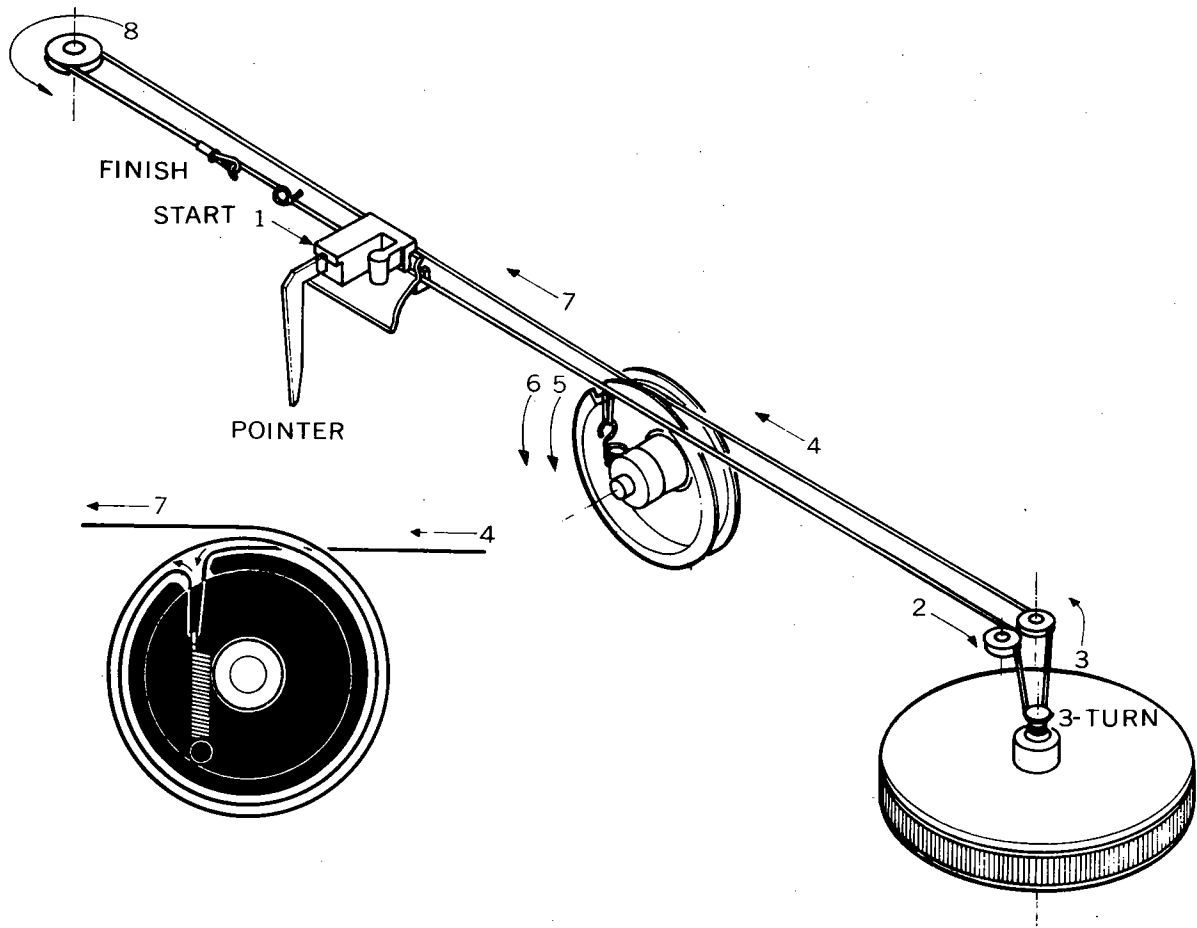

Figure 5. Dial Stringing

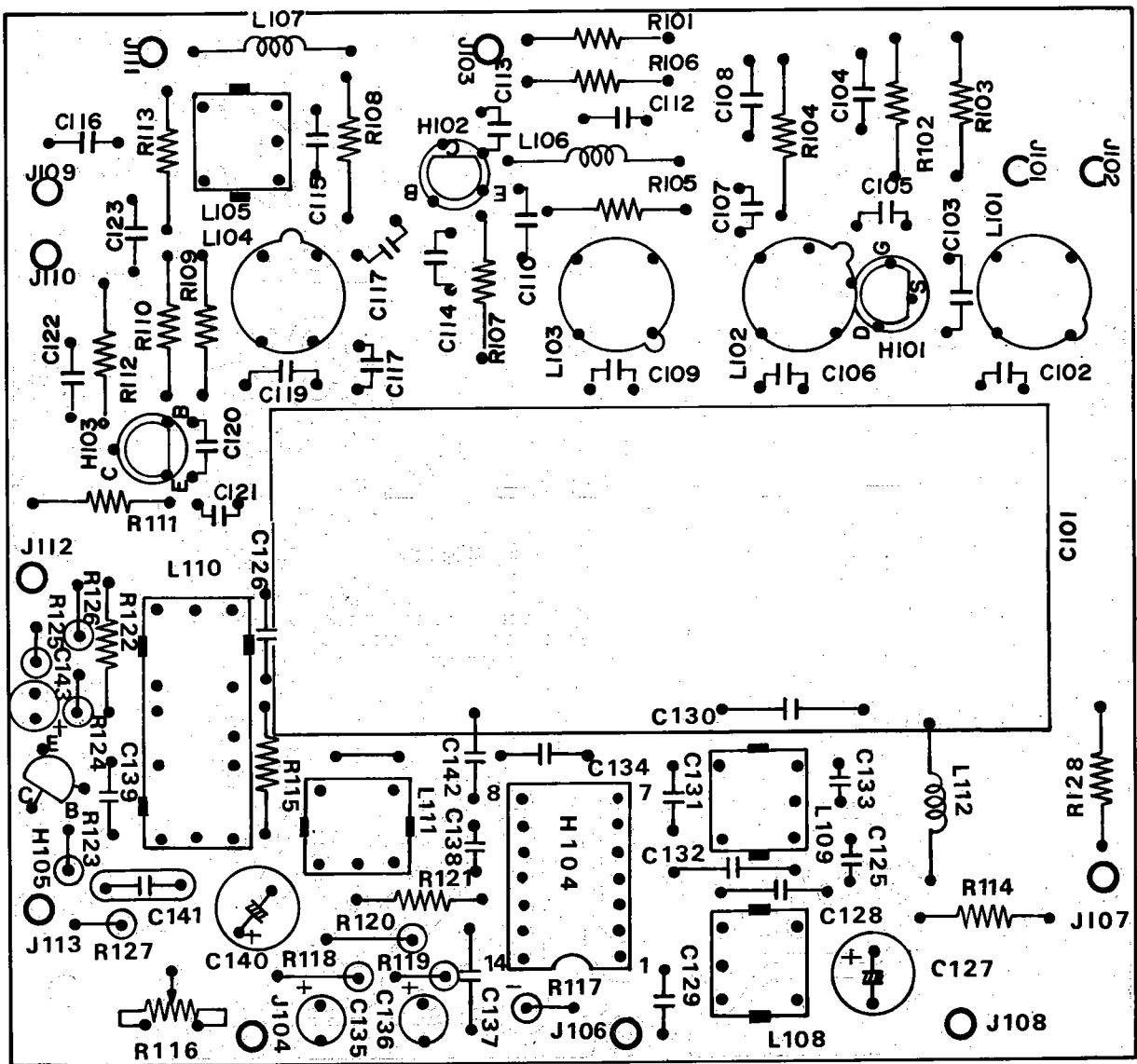

Figure 6. FM Front End and AM Tuner Assembly P100 Component Locations

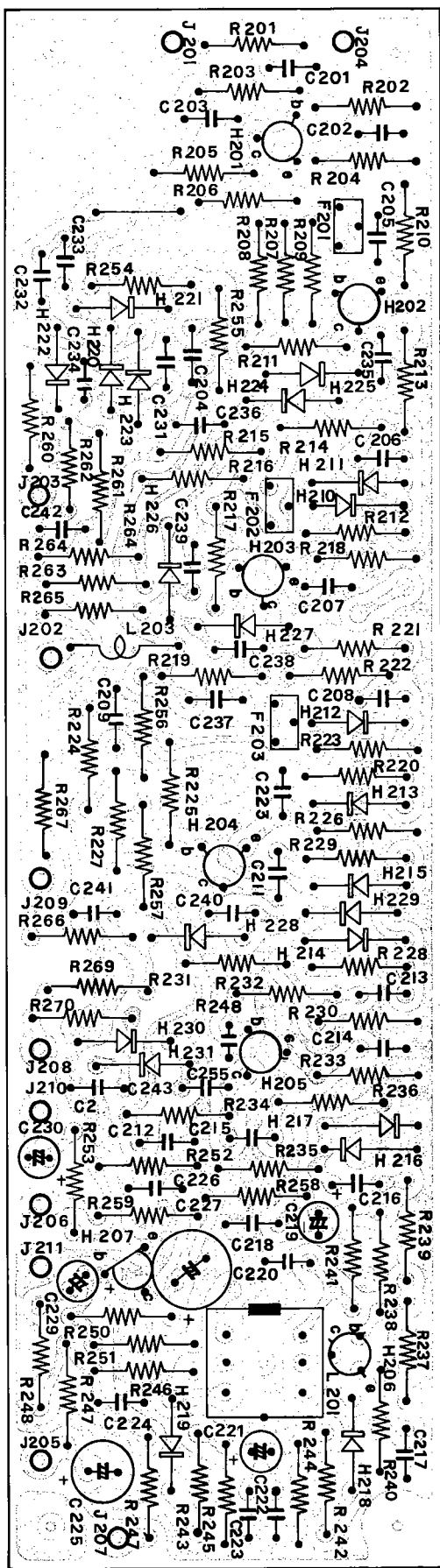

Figure 7. FM IF Amplifier Assembly P200 Component Locations

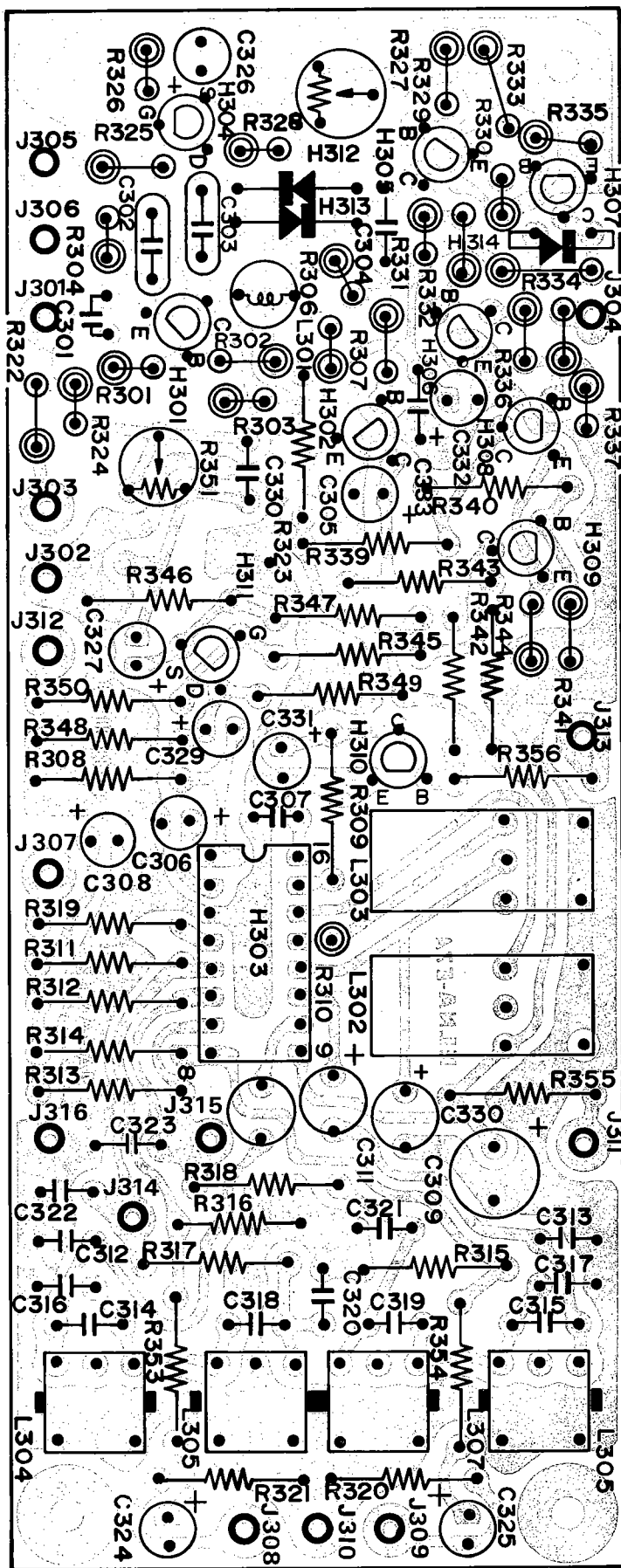

Figure 8. MPX Stereo Decoder, Noise and DC Amplifier Assembly P300 Component Locations

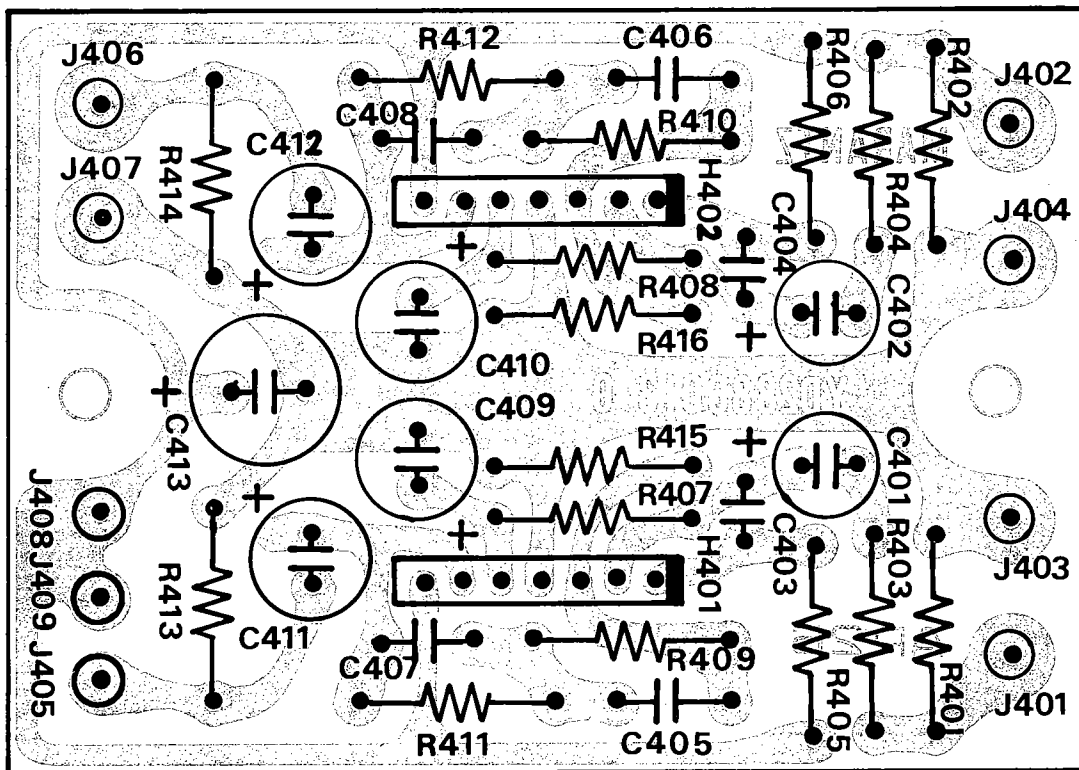

Figure 9. Phono Amplifier Assembly P400 Component Locations

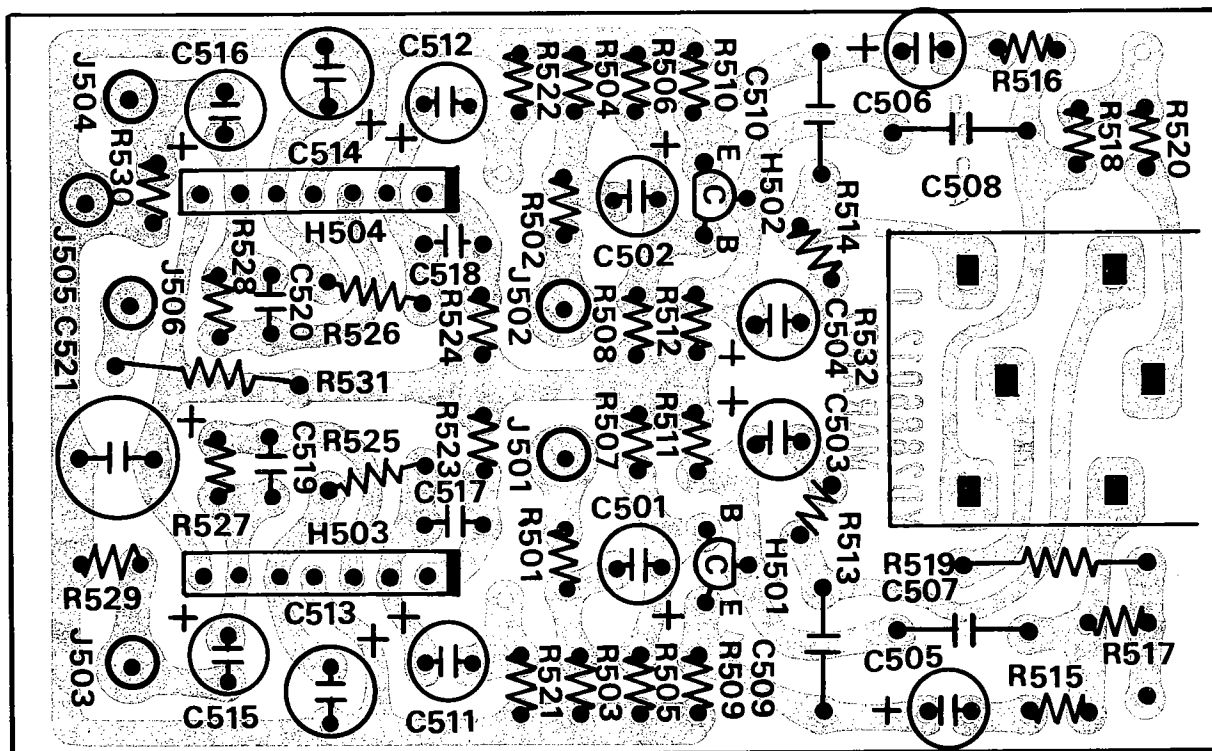

Figure 10. Vari-Matrix Unit Assembly P500 Component Locations

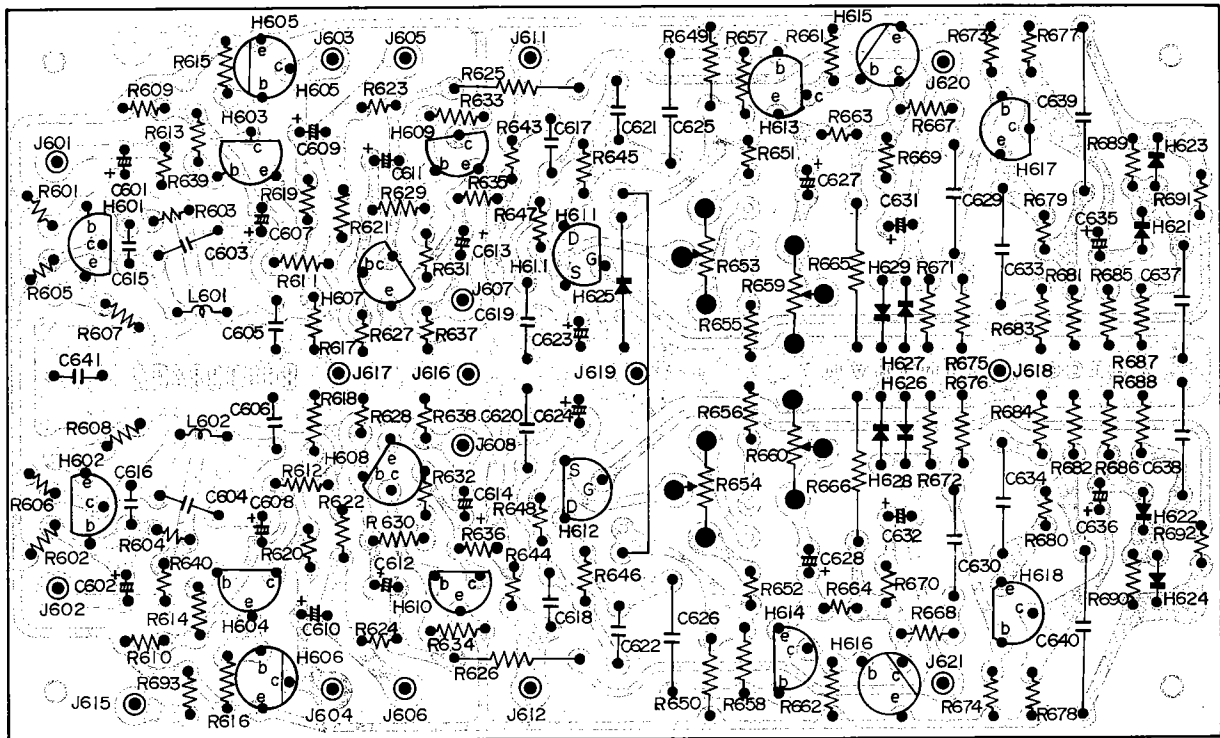

Figure 11. Dolby Unit Assembly P600 Component Locations

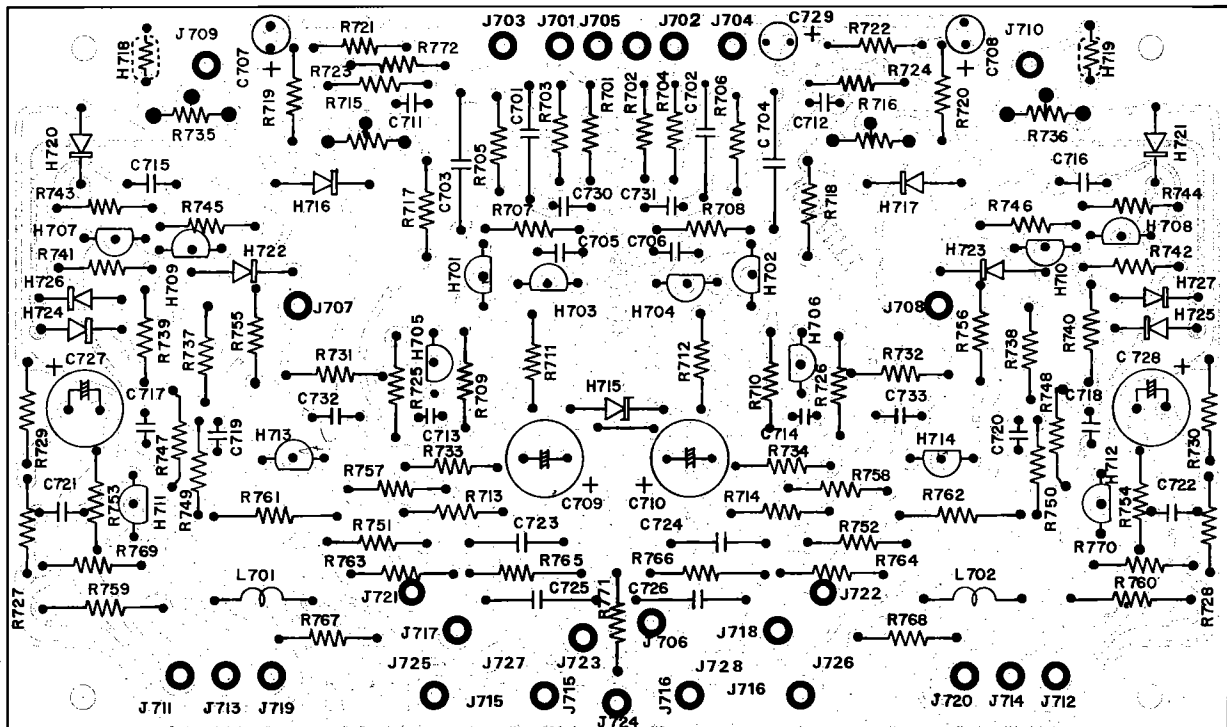

Figure 12. Power Amplifier Assembly P700 Component Locations

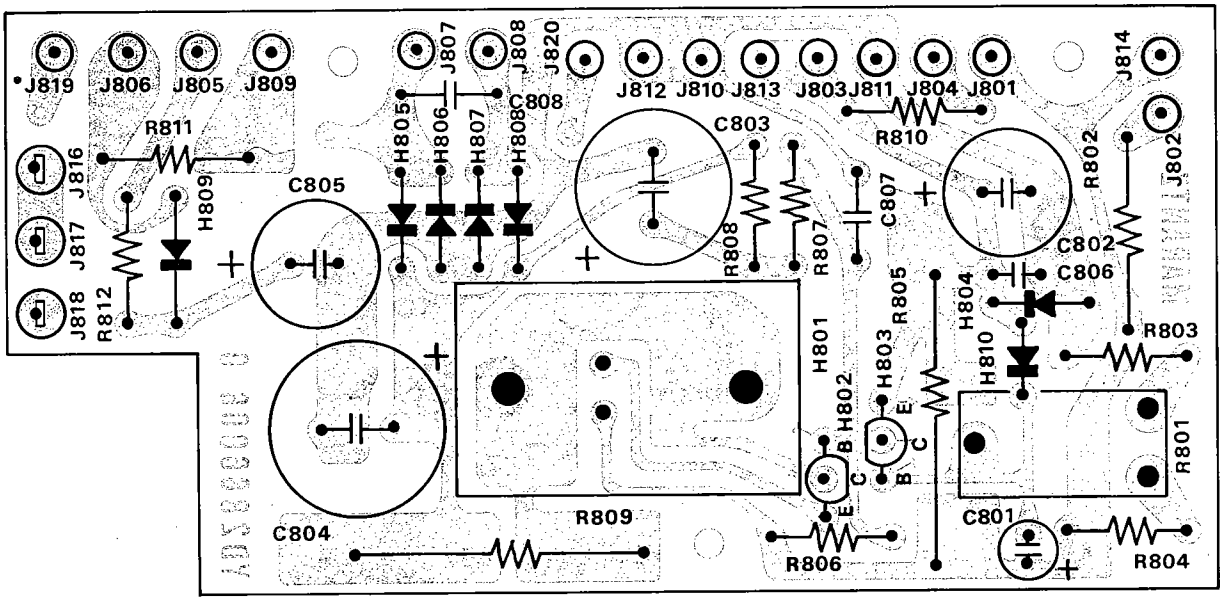

Figure 13. Power Supply Assembly P800 Component Locations

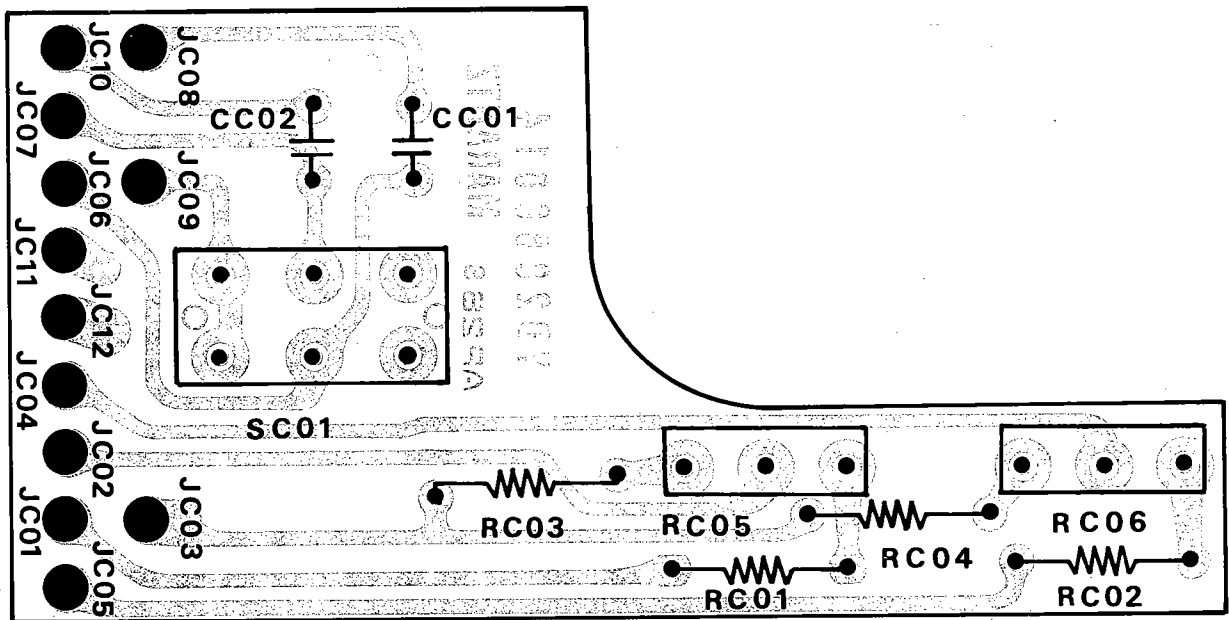

Figure 14. FM De-emphasis Switch Unit Assembly PC01 Component Locations

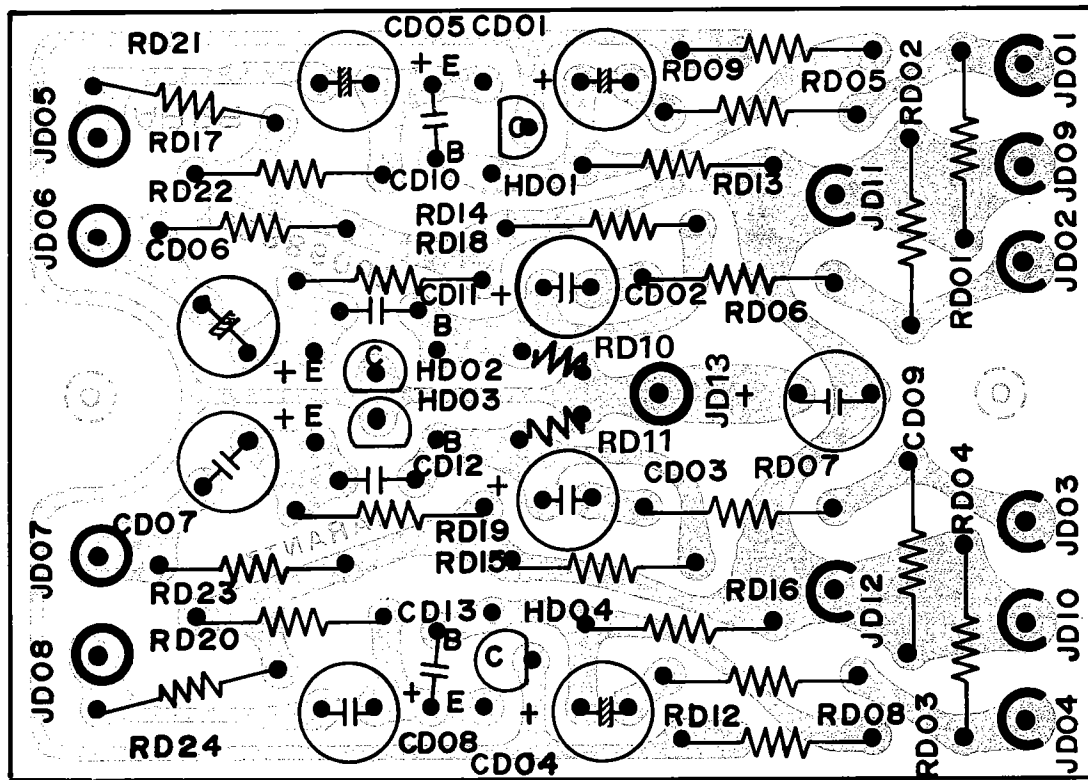

Figure 15. Buffer Amplifier Assembly PD01 Component Locations

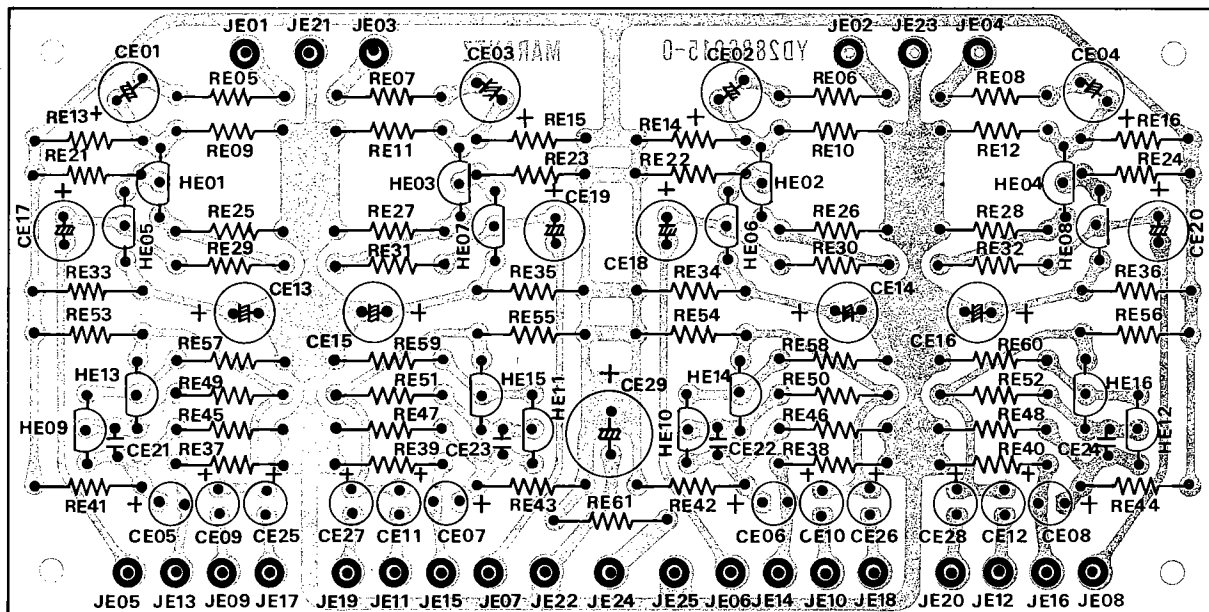

Figure 16. Tone Amplifier Assembly PE01 Component Locations

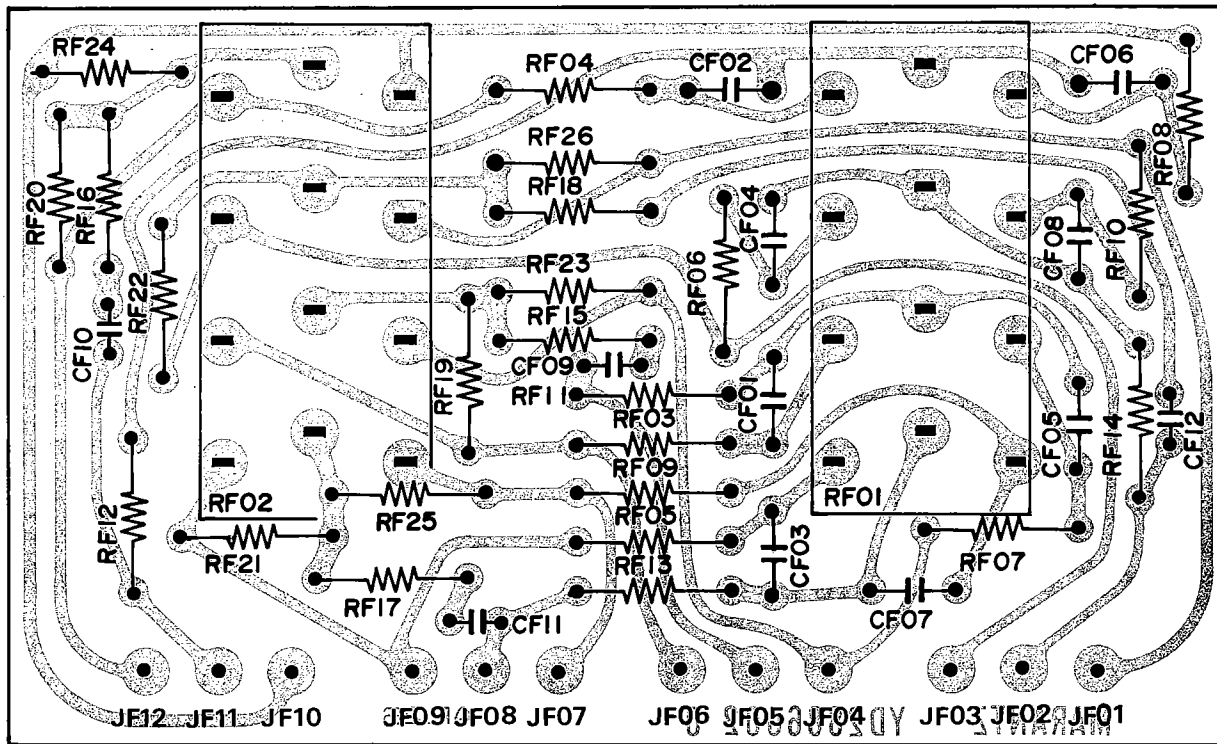

Figure 17. Tone Control Unit Assembly PF01 Component Locations

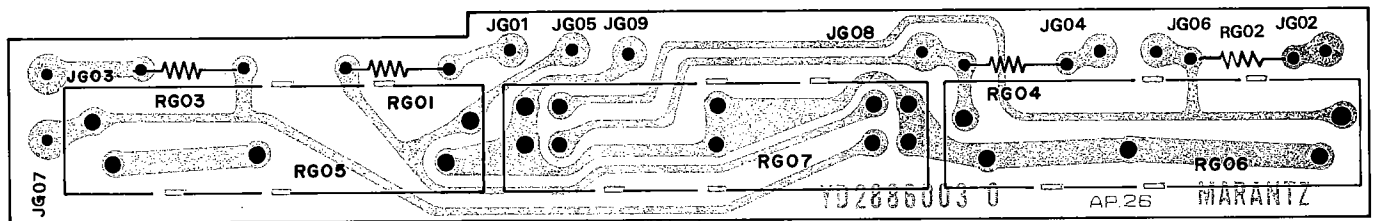

Figure 18. Balance Control Unit Assembly PG01 Component Locations

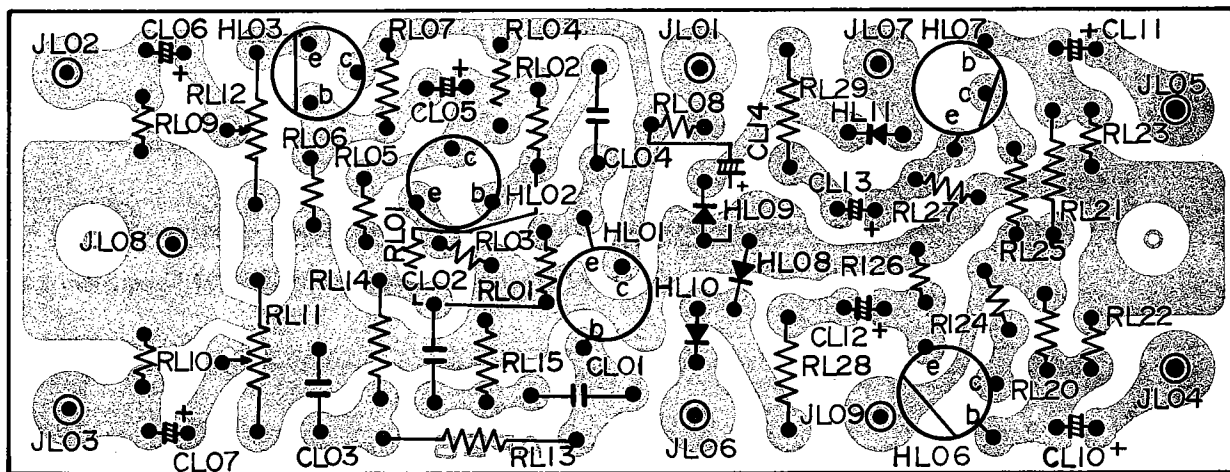

Figure 19. 400Hz Oscillator and Meter Driver Assembly PL01 Component Locations

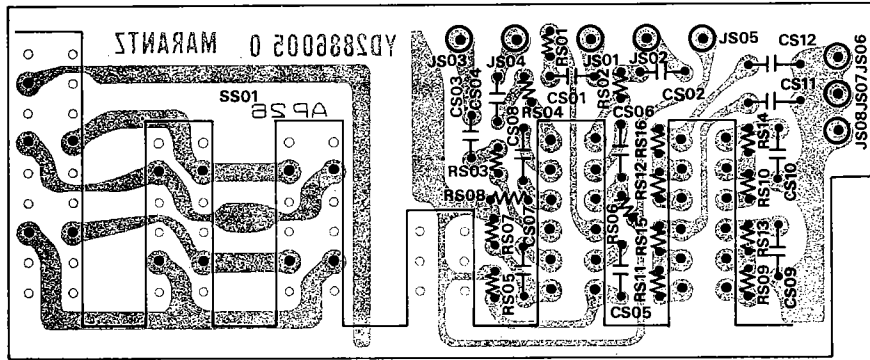

Figure 20. Loudness, Hi Filter, Speaker and Power Switch Unit Assembly, PS01 Component Locations

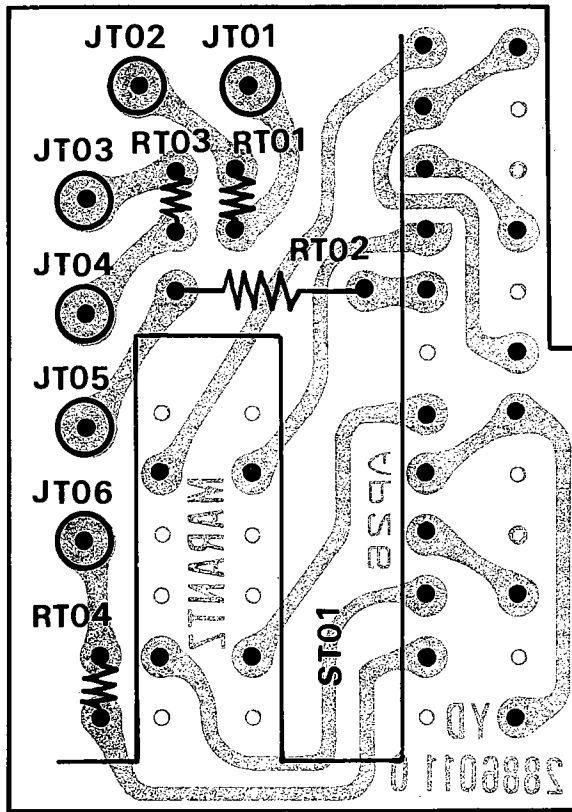

Figure 21. Tape Monitor Switch Unit Assembly PT01 Component Locations

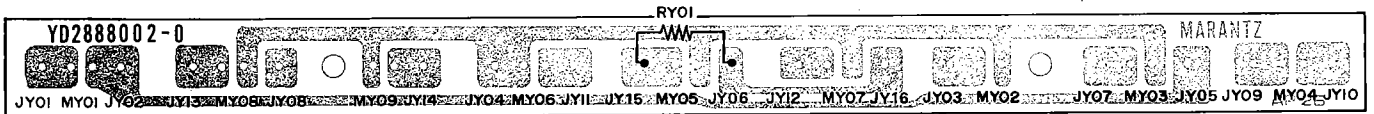

Figure 22. Indicator Lamps Assembly PY01 Component Locations

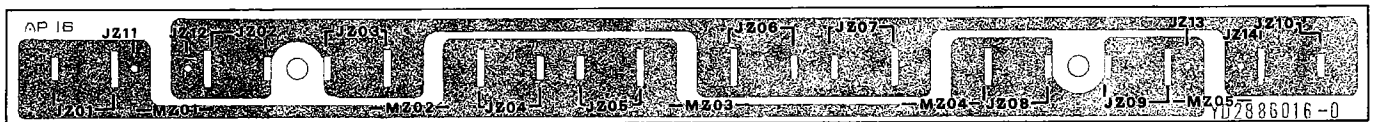

Figure 23. Dial Lamps Assembly PZ01 Component Locations

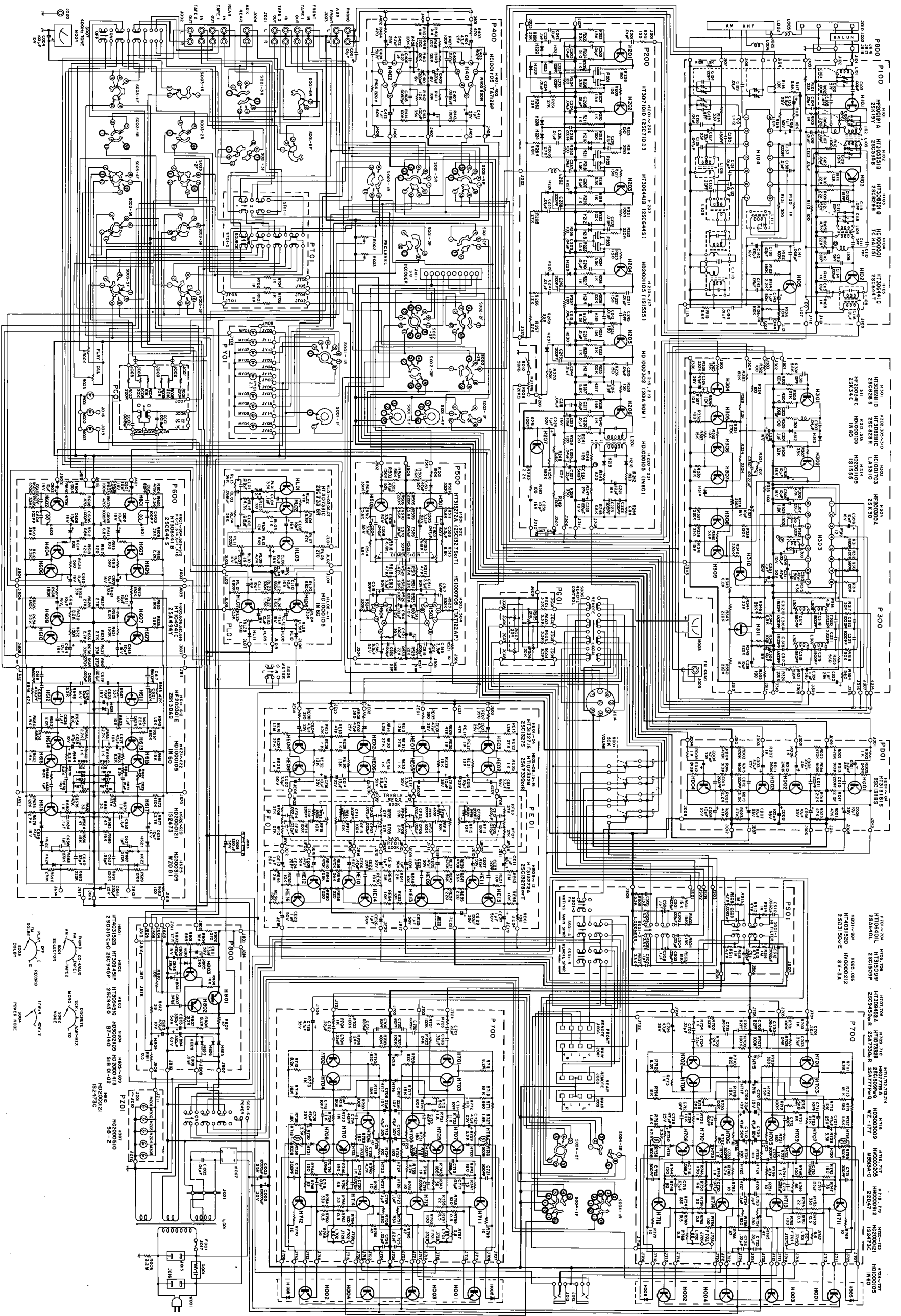

Figure 24. Schematic Diagram

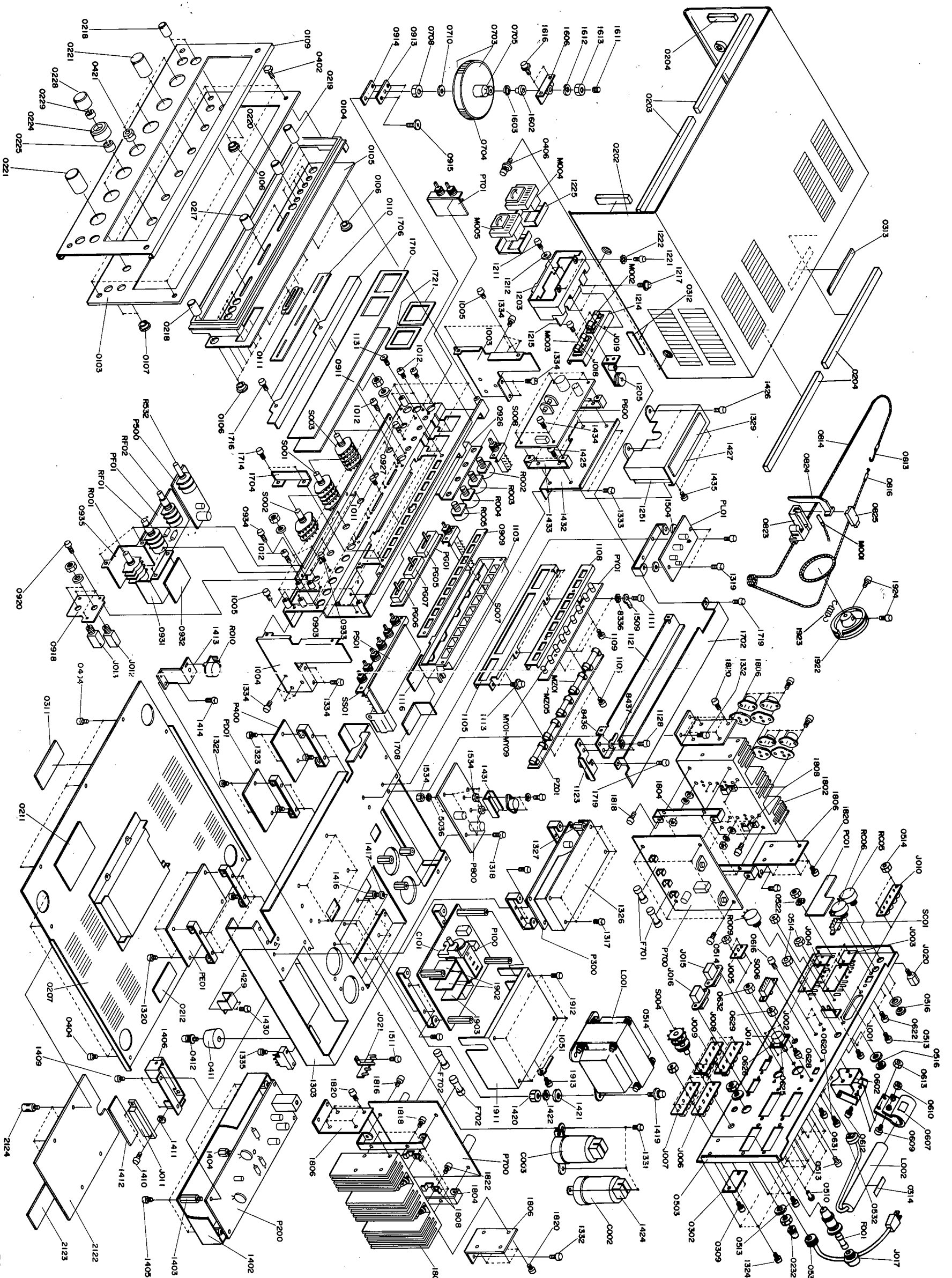

Figure 25. Exploded Mechanical Diagram

TRACOM

PARTS LIST

REF. DESIG.	MARANTZ PART NO.	DESCRIPTION	REF. DESIG.	MARANTZ PART NO.	DESCRIPTION
A	288806340	Front Panel Assembly	R103	RT0510514	1MΩ
0103	288806301	Escutcheon	R104	RT0522114	220Ω
0104	285340101	Frame	R105	RT0547214	4.7KΩ
0105	288615801	Window	R106	RT0522314	22KΩ
0106	288625901	Bush x 10	R107	RT0510214	1KΩ
0107	273125901	Bush x 2	R108	RT0510214	1KΩ
0109	288605302	Cover	R109	RT0522314	22KΩ
0110	289010701	Sheet	R110	RT0522314	22KΩ
0111	285025901	Bush x 3	R111	RT0512214	1.2KΩ
B	288825740	Lid Assembly	R112	RT0510114	100Ω
0207	285325750	Lid K	R113	RT0510114	100Ω
0211	288812001	Insulator	R114	RT0533114	330Ω
0212	288612005	Insulator	R115	RT0556214	5.6KΩ
C	281815440	Knob Assembly	R116	RA0103020	Trimming, 10KΩ
0224	281815404	Knob	R117	RT0556214	5.6KΩ
0225	71400149Q	Spring	R118	RT0510314	10KΩ
D	281815441	Knob Assembly	R119	RT0510314	10KΩ
0228	281815405	Knob	R120	RT0510214	1KΩ
0229	71400159Q	Spring	R121	RT0530114	300Ω
E	288816040	Rear Panel Assembly	R122	RT0510414	100KΩ
0503	288816001	Bracket	R123	RT0518414	180KΩ
0510	55060365S	T.R. Rivet x 4	R124	RT0522214	2.2KΩ
J015	YJ0400018	Jack	R125	RT0518214	1.8KΩ
J016	YJ0400018	Jack	R126	RT0510414	100KΩ
F	285327340	Fly Wheel Assembly	R127	RT0510114	100Ω
0703	257706302	Escutcheon x 2	R128	RC1015212	1.5KΩ ± 10%, ½W
0704	257727301	Fly Wheel	C101	CA4330002	CAPACITORS Variable, AM, FM Gang
0705	285311201	Shaft	C102	DD1205001	Ceramic, 5PF ± 10%
0708	53110603E	Hexagon Nut	C103	DK1710201	Ceramic, 0.001μF ± 20%
0710	54020601E	Flat Washer	C104	DK1710301	Ceramic, 0.01μF ± 20%
G	120200640	String Assembly	C105	DD1001001	Ceramic, 1PF ± 0.25PF
0813	120225701	Hook	C106	DD1615001	Ceramic, 15PF ± 10%
0814	72080802A	String	C107	DK1710201	Ceramic, 0.001μF ± 20%
H	281810341	Pointer Assembly	C108	DK1710301	Ceramic, 0.01μF ± 20%
0823	281810301	Pointer	C109	DD1615001	Ceramic, 15PF ± 10%
0824	281810302	Pointer	C110	DD1203001	Ceramic, 3PF ± 1PF
0825	281805301	Cover	C111	DD1103001	Ceramic, 3PF ± 0.5PF
M001	IN1008030	Lamp	C112	DD1530101	Ceramic, 300PF ± 5%
I	281915941	Drum Assembly	C113	DD1615001	Ceramic, 15PF ± 10%
1922	281915901	Drum	C114	DK1710201	Ceramic, 0.001μF ± 20%
1923	71101569M	Spring	C115	DK1710301	Ceramic, 0.01μF ± 20%
1924	51064019A	Screw	C116	DK1710301	Ceramic, 0.01μF ± 20%
P100	YD2888003	P.W. Board, FM-AM Front	C117	DD1620004	Ceramic, 20PF ± 10%
	ZZ2888003	P.W. Board Ass'y	C118	CT1100008	Trimming, 1.5PF ~ 10PF
		RESISTORS	C119	DD1210006	Ceramic, 10PF ± 1PF
		All resistors are ±5% and ½W,	C120	DD1615003	Ceramic, 15PF ± 10%
		unless otherwise indicated.	C121	DD1615003	Ceramic, 15PF ± 10%
R101	RT0522314	22KΩ	C122	DK1710301	Ceramic, 0.01μF ± 20%
R102	RT0510414	100KΩ	C123	DK1710301	Ceramic, 0.01μF ± 20%
			C126	DK1840302	Ceramic, 0.04μF +80%, -20%
			C127	EA4760259	Electroly, 47μF, 25V
			C128	DF1747301	Film, 0.047μF ± 20%
			C129	DK1710301	Ceramic, 0.01μF ± 20%
			C130	DF6539101	Film, 390PF ± 5%
			C131	DK1710301	Ceramic, 0.01μF ± 20%
			C132	DF1710301	Film, 0.01μF ± 20%
			C133	DD1620001	Ceramic, 20PF ± 10%
			C134	DK1710301	Ceramic, 0.01μF ± 20%
			C135	EA3350259	Electroly, 3.3μF, 25V
			C136	EA1050509	Electroly, 1μF, 50V
			C137	DK1710201	Ceramic, 1000PF ± 20%
			C138	DF1710301	Film, 0.01μF ± 20%

REF. DESIG.	MARANTZ PART NO.	DESCRIPTION
C139	DK1820302	Ceramic, 0.02 μ F +100%, -0%
C140	EA1070169	Electroly, 100 μ F, 16V
C141	DF1668301	Film, 0.068 μ F \pm 10%
C142	DK1840302	Ceramic, 0.04 μ F +80%, -20%
C143	EA1050509	Electroly, 1 μ F, 50V
C144	DK1820302	Ceramic, 0.02 μ F +100%, -0%
SEMICONDUCTORS		
H101	HF200191A	FET, 2SK19 (Y)
H102	HT305351B	Transistor, 2SC535 (B)
H103	HT308291B	Transistor, 2SC829 (B)
H104	HC1000301	IC, HA1151
H105	HT306441C	Transistor, 2SC644T
COILS & TRANSFORMERS		
L101	LA1202603	Ant, Coil, FM
L102	LA1202604	RF, Coil, FM
L103	LA1202611	RF, Coil, FM
L104	LO1202608	OSC, Coil, FM
L105	LI1015602	FM IFT
L106	LC1751001	Choke Coil, 0.75 μ H
L107	LC1332002	Choke Coil, 3.3 μ H
L108	LA1001017	AM RF Coil
L109	LO1001048	AM OSC Coil
L110	LI1028002	AM IFT
L111	LI1001064	AM IFT
L112	LC1332002	Choke Coil, 3.3 μ H
MISCELLANEOUS		
J101	YP1000113	Plug
J102	YP1000113	Plug
J103	YP1000113	Plug
J104	YP1000113	Plug
J106	YP1000113	Plug
J107	YP1000113	Plug
J108	YP1000113	Plug
J109	YP1000113	Plug
J110	YP1000113	Plug
J111	YP1000113	Plug
J112	YP1000113	Plug
J113	YP1000113	Plug
J114	YP1000113	Plug
1902	282110901	Shield x 2
1903	288810901	Shield
P200	YD2888004 ZZ2888004	P.W. Board, FM IFT P.W. Board Ass'y
RESISTORS		
All resistors are \pm 5% and $\frac{1}{4}$ W.		
R201	RT0515114	150 Ω
R202	RT0515214	1.5K Ω
R203	RT0533214	3.3K Ω
R204	RT0551114	510 Ω
R205	RT0510214	1K Ω
R206	RT0515114	150 Ω
R207	RT0515214	1.5K Ω
R208	RT0533214	3.3K Ω
R209	RT0515114	150 Ω
R210	RT0510214	1K Ω

REF. DESIG.	MARANTZ PART NO.	DESCRIPTION
R211	RT0510214	1K Ω
R212	RT0510414	100K Ω
R213	RT0515114	150 Ω
R214	RT0522114	220 Ω
R215	RT0515214	1.5K Ω
R216	RT0533214	3.3K Ω
R217	RT0515114	150 Ω
R218	RT0510214	1K Ω
R219	RT0510214	1K Ω
R220	RT0510414	100K Ω
R221	RT0510114	100 Ω
R222	RT0533114	330 Ω
R223	RT0515214	1.5K Ω
R224	RT0533214	3.3K Ω
R225	RT0515114	150 Ω
R226	RT0510214	1K Ω
R227	RT0510214	1K Ω
R228	RT0510414	100K Ω
R229	RT0515114	150 Ω
R230	RT0582214	8.2K Ω
R231	RT0515314	15K Ω
R232	RT0515114	150 Ω
R233	RT0510214	1K Ω
R234	RT0510214	1K Ω
R235	RT0510414	100K Ω
R236	RT0515114	150 Ω
R237	RT0556214	5.6K Ω
R238	RT0515314	15K Ω
R239	RT0515114	150 Ω
R240	RT0510214	1K Ω
R241	RT0522114	220 Ω
R242	RT0582114	820 Ω
R243	RT0582114	820 Ω
R244	RT0568214	6.8K Ω
R245	RT0568214	6.8K Ω
R246	RT0510114	100 Ω
R247	RT0527314	27K Ω
R248	RT0556214	5.6K Ω
R249	RT0510414	100K Ω
R250	RT0518414	180K Ω
R251	RT0510414	100K Ω
R252	RT0522214	2.2K Ω
R253	RT0510114	100 Ω
R254	RT0510114	100 Ω
R255	RT0510114	100 Ω
R256	RT0510114	100 Ω
R257	RT0510114	100 Ω
R258	RT0510114	100 Ω
R259	RT0533114	330 Ω
R260	RT0533314	33K Ω
R261	RT0527314	27K Ω
R262	RT0524314	24K Ω
R263	RT0527314	27K Ω
R264	RT0568314	68K Ω
R265	RT0527314	27K Ω
R266	RT0512314	12K Ω
R267	RT0527314	27K Ω
R269	RT0533314	33K Ω
R270	RT0512414	120K Ω
CAPACITORS		
C201	DK1710301	Ceramic, 0.01 μ F \pm 20%
C202	DK1710301	Ceramic, 0.01 μ F \pm 20%
C203	DK1840302	Ceramic, 0.04 μ F \pm 20%

REF. DESIG.	MARANTZ PART NO.	DESCRIPTION		REF. DESIG.	MARANTZ PART NO.	DESCRIPTION	
C204	DK1840302	Ceramic,	0.04 μ F \pm 20%	H223	HD1000105	Diode,	1N60
C205	DK1710301	Ceramic,	0.01 μ F \pm 20%	H224	HD1000105	Diode,	1N60
C206	DK1710301	Ceramic,	0.01 μ F \pm 20%	H225	HD1000105	Diode,	1N60
C207	DK1710301	Ceramic,	0.01 μ F \pm 20%	H226	HD1000105	Diode,	1N60
C208	DK1710301	Ceramic,	0.01 μ F \pm 20%	H227	HD1000105	Diode,	1N60
C209	DK1840302	Ceramic,	0.04 μ F \pm 20%	H228	HD1000105	Diode,	1N60
C210	DK1710301	Ceramic,	0.01 μ F \pm 20%	H229	HD1000105	Diode,	1N60
C211	DK1710301	Ceramic,	0.01 μ F \pm 20%	H230	HD1000105	Diode,	1N60
C212	DK1840302	Ceramic,	0.04 μ F \pm 20%	H231	HD1000105	Diode,	1N60
C213	DK1710301	Ceramic,	0.01 μ F \pm 20%			COIL & TRANSFORMER	
C214	DK1710301	Ceramic,	0.01 μ F \pm 20%	L201	LI1401623	FM IFT	
C215	DK1710301	Ceramic,	0.01 μ F \pm 20%	L202	LC1332002	Choke Coil,	3.3 μ H
C216	DK1710301	Ceramic,	0.01 μ F \pm 20%			MISCELLANEOUS	
C217	DK1710301	Ceramic,	0.01 μ F \pm 20%	F201	FF1107004	Ceramic Filter,	CFS10.7M
C218	DK1840301	Ceramic,	0.04 μ F \pm 20%	F202	FF1107004	Ceramic Filter,	CFS10.7M
C219	EA1060169	Electroly,	10 μ F, 16V	F203	FF1107004	Ceramic Filter,	CFS10.7M
C220	DK1710301	Ceramic,	0.01 μ F \pm 20%	J201			
C221	EA1060169	Electroly,	10 μ F, 16V	J211	YP1000113	Plug	
C222	DD1620101	Ceramic,	200PF \pm 10%				
C223	DD1620101	Ceramic,	200PF \pm 10%				
C224	DD1650101	Ceramic,	500PF \pm 10%				
C225	EA1070109	Electroly,	100 μ F, 10V				
C226	DK1840301	Ceramic,	0.04 μ F \pm 20%				
C227	EA4760259	Electroly,	47 μ F, 25V	P300	YD2888005	P.W. Board,	MPX.
C229	EA1050509	Electroly,	1 μ F, 50V		ZZ2888005	P.W. Board Ass'y	
C230	EA1060169	Electroly,	10 μ F, 16V				
C231	DK1710301	Ceramic,	0.01 μ F \pm 20%				
							RESISTORS
							All resistors are \pm 5% and $\frac{1}{4}$ W, unless otherwise indicated.
C232	DD1610101	Ceramic,	100PF \pm 10%	R301	RT0556214	5.6K Ω	
C233	DD1610101	Ceramic,	100PF \pm 10%	R302	RT0510414	100K Ω	
C234	DK1710301	Ceramic,	0.01 μ F \pm 20%	R303	RT0527314	27K Ω	
C235	DD1620101	Ceramic,	200PF \pm 10%	R304	RT0510214	1K Ω	
C236	DK1710301	Ceramic,	0.01 μ F \pm 20%	R305	RT0510114	100 Ω	
C237	DK1840302	Ceramic,	0.04 μ F \pm 20%	R306	RT0533314	33K Ω	
C238	DD1620101	Ceramic,	200PF \pm 10%	R307	RT0533314	33K Ω	
C239	DK1710301	Ceramic,	0.01 μ F \pm 20%	R308	RT0547214	4.7K Ω	
C240	DD1620101	Ceramic,	200PF \pm 10%	R309	RT0527214	2.7K Ω	
C241	DK1710301	Ceramic,	0.01 μ F \pm 20%	R310	RT0533414	330K Ω	
C242	DK1710301	Ceramic,	0.01 μ F \pm 20%	R311	RT0568414	680K Ω	
C243	DD1620101	Ceramic,	200PF \pm 10%	R312	RT0510414	100K Ω	
C244	DK1710301	Ceramic,	0.01 μ F \pm 20%	R313	RT0568414	680K Ω	
C245	DD1540001	Ceramic,	40PF \pm 5%	R314	RT0510414	100K Ω	
				R315	RT0543214	4.3K Ω	
				R316	RT0543214	4.3K Ω	
				R317	RT0530314	30K Ω	
				R318	RT0530314	30K Ω	
				R320	RT0522414	220K Ω	
				R321	RT0522414	220K Ω	
				R322	RT0510114	100 Ω	
				R323	RT0510114	100 Ω	
				R324	RT0510114	100 Ω	
				R325	RT0515314	15K Ω	
				R326	RT0533414	330K Ω	
				R327	RA0103020	Trimming, 10K Ω	
				R328	RT0522214	2.2K Ω	
				R329	RT0510314	10K Ω	
				R330	RT0510114	100 Ω	
				R331	RT0527414	270K Ω	
				R332	RT0510314	10K Ω	
				R333	RT0515314	15K Ω	
				R334	RT0522414	220K Ω	
				R335	RT0512314	12K Ω	
				R336	RT0522114	220 Ω	
H201	HT307101D	Transistor,	2SC710 (D)				
H202	HT307101D	Transistor,	2SC710 (D)				
H203	HT307101D	Transistor,	2SC710 (D)				
H204	HT307101D	Transistor,	2SC710 (D)				
H205	HT307101D	Transistor,	2SC710 (D)				
H206	HT307101D	Transistor,	2SC710 (D)				
H207	HT306441B	Transistor,	2SC644 (S)				
H210	HD2001105	Diode,	1S1555				
H211	HD2001105	Diode,	1S1555				
H212	HD2001105	Diode,	1S1555				
H213	HD2001105	Diode,	1S1555				
H214	HD2001105	Diode,	1S1555				
H215	HD2001105	Diode,	1S1555				
H216	HD2001105	Diode,	1S1555				
H217	HD2001105	Diode,	1S1555				
H218	HD1000302	Diode,	20A90M				
H219	HD1000302	Diode,	20A90M				
H220	HD1000105	Diode,	1N60				
H221	HD1000105	Diode,	1N60				
H222	HD1000105	Diode,	1N60				

REF. DESIG.	MARANTZ PART NO.	DESCRIPTION
R337	RT0522414	220K Ω
R338	RT0533014	33 Ω
R339	RT0512414	120K Ω
R340	RT0556214	5.6K Ω
R341	RT0515314	15K Ω
R342	RT0522414	220K Ω
R343	RT0568214	6.8K Ω
R344	RT0533314	33K Ω
R345	RT0522414	220K Ω
R346	RT0556314	56K Ω
R347	RT0568314	68K Ω
R348	RT0510414	100K Ω
R349	RT0512414	120K Ω
R350	RT0522414	220K Ω
R351	RA0103020	Trimming, 10K Ω
R352	RT0520314	20K Ω
R353	RT0556114	560 Ω
R354	RT0556114	560 Ω
R355	RT0510114	100 Ω
CAPACITORS		
C301	DD1615001	Ceramic, 15PF \pm 10%
C302	DF1668301	Film, 0.068 μ F \pm 10%
C303	DF1740301	Film, 0.04 μ F \pm 20%
C304	DK1810402	Ceramic, 0.1 μ F +80%, -20%
C305	EA1060169	Electroly, 10 μ F, 16V
C306	EA1060169	Electroly, 10 μ F, 16V
C307	DF1610201	Film, 0.001 μ F \pm 10%
C308	EA1060169	Electroly, 10 μ F, 16V
C309	EA3360109	Electroly, 33 μ F, 10V
C310	EA4740501	Electroly, 0.47 μ F, 50V
C311	EA4740501	Electroly, 0.47 μ F, 50V
C312	DF1615205	Film, 1500PF \pm 10%
C313	DF1615205	Film, 1500PF \pm 10%
C314	DD1536101	Ceramic, 360PF \pm 5%
C315	DD1536101	Ceramic, 360PF \pm 5%
C316	DF1633205	Film, 3300PF \pm 10%
C317	DF1633205	Film, 3300PF \pm 10%
C318	DF1515205	Film, 1500PF \pm 5%
C319	DF1515205	Film, 1500PF \pm 5%
C320	DF1622205	Film, 2200PF \pm 10%
C321	DF1622205	Film, 2200PF \pm 10%
C322	DF1510205	Film, 1000PF \pm 5%
C323	DF1510205	Film, 1000PF \pm 5%
C324	EV1050251	Electroly, 1 μ F, 25V
C325	EV1050251	Electroly, 1 μ F, 25V
C326	EA4750359	Electroly, 4.7 μ F, 35V
C327	EA1060169	Electroly, 10 μ F, 16V
C328	EA2270169	Electroly, 220 μ F, 16V
C329	EA1060169	Electroly, 10 μ F, 16V
C330	DF1722201	Film, 0.0022 μ F \pm 20%
C331	EA1050509	Electroly, 50V, 1 μ F
C332	EA1060169	Electroly, 16V, 10 μ F
C333	DK1840301	Ceramic, 0.04 μ F +80%, -20%
SEMICONDUCTORS		
H301	HT308281D	Transistor, 2SC828 (S)
H302	HT308281C	Transistor, 2SC828 (R)
H303	HC1001703	IC, LA3310
H304	HF200300A	FET, 2SK30
H305	HT308281C	Transistor, 2SC828 (R)
H306	HT308281C	Transistor, 2SC828 (R)
H307	HT308281C	Transistor, 2SC828 (R)
H308	HT308281C	Transistor, 2SC828 (R)

REF. DESIG.	MARANTZ PART NO.	DESCRIPTION
H309	HT308281C	Transistor, 2SC828 (R)
H310	HT308281C	Transistor, 2SC828 (R)
H311	HF200341C	FET, 2SK34 (C)
H312	HD1000105	Diode, 1N60
H313	HD1000105	Diode, 1N60
H314	HD2001105	Diode, 1S1555
COIL		
L301	LC2105001	Choke Coil, 1mH
L302	LS1031001	MPX Coil, 19KHz
L303	LS1031004	MPX Coil, 38KHz
L304	LS1029004	MPX Coil, 56mH
L305	LS1029004	MPX Coil, 56mH
L306	LS1029005	MPX Coil, 43mH
L307	LS1029005	MPX Coil, 43mH
MISCELLANEOUS		
J301	YP1000113	Plug
J316		
C007	DK1840302	Ceramic, 0.04 μ F +80%, -20%
P400	YD2886013 ZZ2886013	P.W. Board, Phono EQ P.W. Board Ass'y
RESISTORS All resistors are \pm 5% and $\frac{1}{4}$ W.		
R401	RT0591314	91K Ω
R402	RT0591314	91K Ω
R403	RT0547114	470 Ω
R404	RT0547114	470 Ω
R405	RN1082414	820K Ω \pm 10%, $\frac{1}{4}$ W
R406	RN1082414	820K Ω \pm 10%, $\frac{1}{4}$ W
R407	RN1010414	100K Ω \pm 10%, $\frac{1}{4}$ W
R408	RN1010414	100K Ω \pm 10%, $\frac{1}{4}$ W
R409	RT0512414	120K Ω
R410	RT0512414	120K Ω
R411	RT0510314	10K Ω
R412	RT0510314	10K Ω
R413	RT0510414	100K Ω
R414	RT0510414	100K Ω
R415	RT0520114	200 Ω
R416	RT0520114	200 Ω
CAPACITORS		
C401	EE4750251	Electroly, 4.7 μ F, 25V
C402	EE4750251	Electroly, 4.7 μ F, 25V
C403	DD1650001	Ceramic, 50PF \pm 10%
C404	DD1650001	Ceramic, 50PF \pm 10%
C405	DF1527305	Film, 0.027 μ F \pm 5%
C406	DF1527305	Film, 0.27 μ F \pm 5%
C407	DF1582205	Film, 0.0082 μ F \pm 5%
C408	DF1582205	Film, 0.0082 μ F \pm 5%
C409	EA2270069	Electroly, 220 μ F, 6V
C410	EA2270069	Electroly, 220 μ F, 6V
C411	EE1050501	Electroly, 1 μ F, 50V
C412	EE1050501	Electroly, 1 μ F, 50V
C413	EA1070359	Electroly, 100 μ F, 35V
SEMICONDUCTORS		
H401	HC1001105	IC, TA7129P

REF. DESIG.	MARANTZ PART NO.	DESCRIPTION
H402	HC1001105	IC, TA7129P
J401 J409	YP1000113	MISCELLANEOUS Plug
P600	YD2886008 ZZ2886008	P.W. Board, Dolby P.W. Board Ass'y
		RESISTORS All resistors are $\pm 5\%$ and $\frac{1}{4}W$, unless otherwise indicated.
R601	RT0547414	470K Ω
R602	RT0547414	470K Ω
R603	RT0510414	100K Ω
R604	RT0510414	100K Ω
R605	RT0533214	3.3K Ω
R606	RT0533214	3.3K Ω
R607	RT0547114	470 Ω
R608	RT0547114	470 Ω
R609	RT0539314	39K Ω
R610	RT0539314	39K Ω
R611	RT0568214	6.8K Ω
R612	RT0568214	6.8K Ω
R613	RT0510114	100 Ω
R614	RT0510114	100 Ω
R615	RT0522214	2.2K Ω
R616	RT0522214	2.2K Ω
R617	RT0512114	120 Ω
R618	RT0512114	120 Ω
R619	RT0556114	560 Ω
R620	RT0556114	560 Ω
R621	RT0533314	33K Ω
R622	RT0533314	33K Ω
R623	RT0515414	150K Ω
R624	RT0515414	150K Ω
R625	RT0518414	180K Ω
R626	RT0518414	180K Ω
R627	RT0527314	27K Ω
R628	RT0527314	27K Ω
R629	RT0582214	8.2K Ω
R630	RT0582214	8.2K Ω
R631	RT0515414	150K Ω
R632	RT0515414	150K Ω
R633	RT0522314	22K Ω
R634	RT0522314	22K Ω
R635	RT0527214	2.7K Ω
R636	RT0527214	2.7K Ω
R637	RT0533314	33K Ω
R638	RT0533314	33K Ω
R639	RT0547414	470K Ω
R640	RT0547414	470K Ω
R643	RT0527414	270K Ω
R644	RT0527414	270K Ω
R645	RT0547314	47K Ω
R646	RT0547314	47K Ω
R647	RT0533214	3.3K Ω
R648	RT0533214	3.3K Ω
R649	RT0515214	1.5K Ω
R650	RT0515214	1.5K Ω
R651	RT0522314	22K Ω
R652	RT0522314	22K Ω

REF. DESIG.	MARANTZ PART NO.	DESCRIPTION
R653	RA0103022	Trimming, 10K Ω (B)
R654	RA0103022	Trimming, 10K Ω (B)
R655	RT0527214	2.7K Ω
R656	RT0527214	2.7K Ω
R657	RT0568414	680K Ω
R658	RT0568414	680K Ω
R659	RA0102020	Trimming, 1K Ω (B)
R660	RA0102020	Trimming, 1K Ω (B)
R661	RT0515314	15K Ω
R662	RT0515314	15K Ω
R663	RT0582214	8.2K Ω
R664	RT0582214	8.2K Ω
R665	RT0510314	10K Ω
R666	RT0510314	10K Ω
R667	RT0582214	8.2K Ω
R668	RT0582214	8.2K Ω
R669	RT0582214	8.2K Ω
R670	RT0582214	8.2K Ω
R671	RT0533314	33K Ω
R672	RT0533314	33K Ω
R673	RT0512414	120K Ω
R674	RT0512414	120K Ω
R675	RT0547314	47K Ω
R676	RT0547314	47K Ω
R677	RT0527214	2.7K Ω
R678	RT0527214	2.7K Ω
R679	RT0510214	1K Ω
R680	RT0510214	1K Ω
R681	RT0533014	33 Ω
R682	RT0533014	33 Ω
R683	RT0547014	47 Ω
R684	RT0547014	47 Ω
R685	RT0515314	15K Ω
R686	RT0515314	15K Ω
R687	RT0527414	270K Ω
R688	RT0527414	270K Ω
R689	RT0527414	270K Ω
R690	RT0527414	270K Ω
R691	RT0522414	220K Ω
R692	RT0522414	220K Ω
R693	RC1010112	100 Ω \pm 10%, $\frac{1}{4}W$
		CAPACITORS
C601	EE3350251	Electroly, 3.3 μF , 25V
C602	EE3350251	Electroly, 3.3 μF , 25V
C603	DF6610101	Film, 100PF \pm 10%
C604	DF6610101	Film, 100PF \pm 10%
C605	DF1510205	Film, 1000PF \pm 5%
C606	DF1510205	Film, 1000PF \pm 5%
C607	EA1060169	Electroly, 10 μF , 16V
C608	EA1060169	Electroly, 10 μF , 16V
C609	EA1060169	Electroly, 10 μF , 16V
C610	EA1060169	Electroly, 10 μF , 16V
C611	EA1060169	Electroly, 10 μF , 16V
C612	EA1060169	Electroly, 10 μF , 16V
C613	EA1060169	Electroly, 10 μF , 16V
C614	EA1060169	Electroly, 10 μF , 16V
C615	DD1582001	Ceramic, 82PF \pm 5%
C616	DD1582001	Ceramic, 82PF \pm 5%
C617	DF1556205	Film, 5600PF \pm 5%
C618	DF1556205	Film, 5600PF \pm 5%
C619	DF1527305	Film, 0.027 μF \pm 5%
C620	DF1527305	Film, 0.027 μF \pm 5%

REF. DESIG.	MARANTZ PART NO.	DESCRIPTION	
C621	DF1547205	Film,	4700PF ± 5%
C622	DF1547205	Film,	4700PF ± 5%
C623	EA1060169	Electroly,	10μF, 16V
C624	EA1060169	Electroly,	10μF, 16V
C625	DF1610405	Film,	0.1μF ± 10%
C626	DF1610405	Film,	0.1μF ± 10%
C627	EA4760109	Electroly,	47μF, 10V
C628	EA4760109	Electroly,	47μF, 10V
C629	DF1610405	Film,	0.1μF ± 10%
C630	DF1610405	Film,	0.1μF ± 10%
C631	EA1060169	Electroly,	10μF, 16V
C632	EA1060169	Electroly,	10μF, 16V
C633	DF1610405	Film,	0.1μF ± 10%
C634	DF1610405	Film,	0.1μF ± 10%
C635	EA1060169	Electroly,	10μF, 16V
C636	EA1060169	Electroly,	10μF, 16V
C637	DF1610405	Film,	0.1μF ± 10%
C638	DF1610405	Film,	0.1μF ± 10%
C639	DF1633405	Film,	0.33μF ± 10%
C640	DF1633405	Film,	0.33μF ± 10%
C641	EA2270259	Electroly,	220μF, 25V
L601	LC2226004	Choke Coil,	22mH
L602	LC2226004	Choke Coil,	22mH
MISCELLANEOUS			
J601 }	YP1000109	Plug	
J608			
J611 }	YP1000109	Plug	
J612			
J615 }	YP1000109	Plug	
J621			
SEMICONDUCTORS			
H601	HT306441B	Transistor,	2SC644 (S)
H602	HT306441B	Transistor,	2SC644 (S)
H603	HT306441B	Transistor,	2SC644 (S)
H604	HT306441B	Transistor,	2SC644 (S)
H605	HT104941C	Transistor,	2SA494 (Y)
H606	HT104941C	Transistor,	2SA494 (Y)
H607	HT306441B	Transistor,	2SC644 (S)
H608	HT306441B	Transistor,	2SC644 (S)
H609	HT306441B	Transistor,	2SC644 (S)
H610	HT306441B	Transistor,	2SC644 (S)
H611	HF200301E	Transistor,	2SK30 (D)
H612	HF200301E	Transistor,	2SK30 (D)
H613	HT306441B	Transistor,	2SC644 (S)
H614	HT306441B	Transistor,	2SC644 (S)
H615	HT104941C	Transistor,	2SA494 (Y)
H616	HT104941C	Transistor,	2SA494 (Y)
H617	HT306441B	Transistor,	2SC644 (S)
H618	HT306441B	Transistor,	2SC644 (S)
H621	HD1000105	Diode,	1N60
H622	HD1000105	Diode,	1N60
H623	HD2000121	Diode,	1S2473
H624	HD2000121	Diode,	1S2473
H625	HD3003109	Diode,	WZ-081

REF. DESIG.	MARANTZ PART NO.	DESCRIPTION	
H626	HD2000121	Diode,	1S2473
H627	HD2000121	Diode,	1S2473
H628	HD2000121	Diode,	1S2473
H629	HD2000121	Diode,	1S2473
1425	51570305B	P.H. Tapt Screw	x 4
1432	288616003	Bracket	
1433	288616004	Bracket	x 2
1434	51100305S	B.H.M. Screw	x 4
1507	54050300R	T.L. Washer OR	x 2
PL01	YD2886009 ZZ2886009	P.W. Board, Dolby Tone & Meter P.W. Board Ass'y	
RESISTORS			
All resistors are ±5% and ¼W, unless otherwise indicated.			
RL01	RT0533214	3.3KΩ	
RL02	RT0547314	47KΩ	
RL03	RT0510114	100Ω	
RL04	RT0533214	3.3KΩ	
RL05	RT0510214	1KΩ	
RL06	RT0512314	12KΩ	
RL07	RT0547314	47KΩ	
RL08	RC1010212	1KΩ ± 10%,	¼W
RL09	RT0547214	4.7KΩ	
RL10	RT0510214	1KΩ	
RL11	RA0501012	Trimming,	500Ω (B)
RL12	RA0502019	Trimming,	5KΩ (B)
RL13	RT0556314	56KΩ	
RL14	RT0556314	56KΩ	
RL15	RT0547214	4.7KΩ	
RL16	RT0533314	33KΩ	
RL20	RT0568414	680KΩ	
RL21	RT0568414	680KΩ	
RL22	RT0533414	330KΩ	
RL23	RT0533414	330KΩ	
RL24	RT0533214	3.3KΩ	
RL25	RT0533214	3.3KΩ	
RL26	RT0515214	1.5KΩ	
RL27	RT0515214	1.5KΩ	
RL28	RA0152004	Trimming,	1.5KΩ (B)
RL29	RA0152004	Trimming,	1.5KΩ (B)
CAPACITORS			
CL01	DF1515305	Film,	0.015μF ± 5%
CL02	DF1515305	Film,	0.015μF ± 5%
CL03	DF1668301	Film,	0.068μF ± 10%
CL04	DF1710402	Film,	0.1μF ± 20%
CL05	EA1060169	Electroly,	10μF, 16V
CL06	EA1060169	Electroly,	10μF, 16V
CL07	EA1060169	Electroly,	10μF, 16V
CL10	EA1060169	Electroly,	10μF, 16V
CL11	EA1060169	Electroly,	10μF, 16V
CL12	EA1060169	Electroly,	10μF, 16V
CL13	EA1060169	Electroly,	10μF, 16V
CL14	EA3360359	Electroly,	33μF, 35V
SEMICONDUCTORS			
HL01	HT307331C	Transistor,	2SC733 (GR)

REF. DESIG.	MARANTZ PART NO.	DESCRIPTION
HL02	HT307331C	Transistor, 2SC733 (GR)
HL03	HT307331C	Transistor, 2SC733 (GR)
HL06	HT307331C	Transistor, 2SC733 (GR)
HL07	HT307331C	Transistor, 2SC733 (GR)
HL08	HD1000105	Diode, 1N60
HL09	HD1000105	Diode, 1N60
HL10	HD1000105	Diode, 1N60
HL11	HD1000105	Diode, 1N60
MISCELLANEOUS		
JL01 ? JL09	YP1000113	Plug
PD01	YD2886007 ZZ2886007	P.W. Board, Buffer P.W. Board Ass'y
RESISTORS All resistors are $\pm 5\%$ and $\frac{1}{4}W$, unless otherwise indicated.		
RD01	RT0547414	470K Ω
RD02	RT0547414	470K Ω
RD03	RT0547414	470K Ω
RD04	RT0547414	470K Ω
RD05	RT0510214	1K Ω
RD06	RT0510214	1K Ω
RD07	RT0510214	1K Ω
RD08	RT0510214	1K Ω
RD09	RT0524414	240K Ω
RD10	RT0524414	240K Ω
RD11	RT0524414	240K Ω
RD12	RT0524414	240K Ω
RD13	RT0591414	910K Ω
RD14	RT0591414	910K Ω
RD15	RT0591414	910K Ω
RD16	RT0591414	910K Ω
RD17	GU0522212	2.2K Ω $\pm 5\%$, $\frac{1}{2}W$
RD18	GU0522212	2.2K Ω $\pm 5\%$, $\frac{1}{2}W$
RD19	GU0522212	2.2K Ω $\pm 5\%$, $\frac{1}{2}W$
RD20	GU0522212	2.2K Ω $\pm 5\%$, $\frac{1}{2}W$
RD21	RT0547314	47K Ω
RD22	RT0547314	47K Ω
RD23	RT0547314	47K Ω
RD24	RT0547314	47K Ω
CAPACITORS		
CD01	EE1050501	Electroly, 1 μF , 50V
CD02	EE1050501	Electroly, 1 μF , 50V
CD03	EE1050501	Electroly, 1 μF , 50V
CD04	EE1050501	Electroly, 1 μF , 50V
CD05	EE1060351	Electroly, 10 μF , 35V
CD06	EE1060351	Electroly, 10 μF , 35V
CD07	EE1060351	Electroly, 10 μF , 35V
CD08	EE1060351	Electroly, 10 μF , 35V
CD09	EA1070359	Electroly, 100 μF , 35V
CD10	DD1620101	Ceramic, 200PF $\pm 10\%$
CD11	DD1620101	Ceramic, 200PF $\pm 10\%$
CD12	DD1620101	Ceramic, 200PF $\pm 10\%$
CD13	DD1620101	Ceramic, 200PF $\pm 10\%$
SEMICONDUCTORS		
HD01	HT313181S	Transistor, 2SC1318 (S)
HD02	HT313181S	Transistor, 2SC1318 (S)
HD03	HT313181S	Transistor, 2SC1318 (S)

REF. DESIG.	MARANTZ PART NO.	DESCRIPTION
HD04	HT313181S	Transistor, 2SC1318 (S)
MISCELLANEOUS		
JD01 ? JD13	YP1000113	Plug
PE01	YD2886015 ZZ2888115	P.W. Board, Tone AMP P.W. Board Ass'y
RESISTORS All resistors are $\pm 5\%$ and $\frac{1}{4}W$.		
RE05	RT0539114	390 Ω
RE06	RT0539114	390 Ω
RE07	RT0539114	390 Ω
RE08	RT0539114	390 Ω
RE09	RT0547314	47K Ω
RE10	RT0547314	47K Ω
RE11	RT0547314	47K Ω
RE12	RT0547314	47K Ω
RE13	RT0512514	1.2M Ω
RE14	RT0512514	1.2M Ω
RE15	RT0512514	1.2M Ω
RE16	RT0512514	1.2M Ω
RE21	RT0527314	27K Ω
RE22	RT0527314	27K Ω
RE23	RT0527314	27K Ω
RE24	RT0527314	27K Ω
RE25	RT0510214	1K Ω
RE26	RT0510214	1K Ω
RE27	RT0510214	1K Ω
RE28	RT0510214	1K Ω
RE29	RT0513314	13K Ω
RE30	RT0513314	13K Ω
RE31	RT0513314	13K Ω
RE32	RT0513314	13K Ω
RE33	RT0510214	1K Ω
RE34	RT0510214	1K Ω
RE35	RT0510214	1K Ω
RE36	RT0510214	1K Ω
RE37	RT0547414	470K Ω
RE38	RT0547414	470K Ω
RE39	RT0547414	470K Ω
RE40	RT0547414	470K Ω
RE41	RT0520514	2M Ω
RE42	RT0520514	2M Ω
RE43	RT0520514	2M Ω
RE44	RT0520514	2M Ω
RE45	RT0556314	56K Ω
RE46	RT0556314	56K Ω
RE47	RT0556314	56K Ω
RE48	RT0556314	56K Ω
RE49	RT0510314	10K Ω
RE50	RT0510314	10K Ω
RE51	RT0510314	10K Ω
RE52	RT0510314	10K Ω
RE53	RT0510314	10K Ω
RE54	RT0510314	10K Ω
RE55	RT0510314	10K Ω
RE56	RT0510314	10K Ω
RE57	RT0522114	220 Ω
RE58	RT0522114	220 Ω

REF. DESIG.	MARANTZ PART NO.	DESCRIPTION
RE59	RT0522114	220Ω
RE60	RT0522114	220Ω
RE61	RT0510114	100Ω
CAPACITORS		
CE01	EE4750251	Electroly, 4.7μF, 25V
CE02	EE4750251	Electroly, 4.7μF, 25V
CE03	EE4750251	Electroly, 4.7μF, 25V
CE04	EE4750251	Electroly, 4.7μF, 25V
CE05	EE4740501	Electroly, 0.47μF, 50V
CE06	EE4740501	Electroly, 0.47μF, 50V
CE07	EE4740501	Electroly, 0.47μF, 50V
CE08	EE4740501	Electroly, 0.47μF, 50V
CE09	EE1050501	Electroly, 1μF, 50V
CE10	EE1050501	Electroly, 1μF, 50V
CE11	EE1050501	Electroly, 1μF, 50V
CE12	EE1050501	Electroly, 1μF, 50V
CE13	EA1060359	Electroly, 10μF, 35V
CE14	EA1060359	Electroly, 10μF, 35V
CE15	EA1060359	Electroly, 10μF, 35V
CE16	EA1060359	Electroly, 10μF, 35V
CE17	EE3350501	Electroly, 3.3μF, 50V
CE18	EE3350501	Electroly, 3.3μF, 50V
CE19	EE3350501	Electroly, 3.3μF, 50V
CE20	EE3350501	Electroly, 3.5μF, 50V
CE21	DD1620001	Ceramic, 20PF ± 10%
CE22	DD1620001	Ceramic, 20PF ± 10%
CE23	DD1620001	Ceramic, 20PF ± 10%
CE24	DD1620001	Ceramic, 20PF ± 10%
CE25	EE1050501	Electroly, 1μF, 50V
CE26	EE1050501	Electroly, 1μF, 50V
CE27	EE1050501	Electroly, 1μF, 50V
CE28	EE1050501	Electroly, 1μF, 50V
CE29	EA1070359	Electroly, 100μF, 35V
MISCELLANEOUS		
JE01 } JE25	YP1000113	Plug
SEMICONDUCTORS		
HE01	HT313271S	Transistor, 2SC1327 (S)
HE02	HT313271S	Transistor, 2SC1327 (S)
HE03	HT313271S	Transistor, 2SC1327 (S)
HE04	HT313271S	Transistor, 2SC1327 (S)
HE05	HT107331Q	Transistor, 2SA733 (Q)
HE06	HT107331Q	Transistor, 2SA733 (Q)
HE07	HT107331Q	Transistor, 2SA733 (Q)
HE08	HT107331Q	Transistor, 2SA733 (Q)
HE09	HT309451Q	Transistor, 2SC945 (Q)
HE10	HT309451Q	Transistor, 2SC945 (Q)
HE11	HT309451Q	Transistor, 2SC945 (Q)
HE12	HT309451Q	Transistor, 2SC945 (Q)
HE13	HT107331Q	Transistor, 2SA733 (Q)
HE14	HT107331Q	Transistor, 2SA733 (Q)
HE15	HT107331Q	Transistor, 2SA733 (Q)
HE16	HT107331Q	Transistor, 2SA733 (Q)
1808	282026702	Heat Sink x 4
1816	51100306S	B.H.M. Screw x 8
1822	51100308S	B.H.M. Screw x 4

REF. DESIG.	MARANTZ PART NO.	DESCRIPTION
SEMICONDUCTORS		
H005	HV0000212	Diode x 2
H006	HV0000212	Diode x 2
1824	51570408B	P.H. Tapt Screw x 2
1826	53110501A	Hexagon Nut x 2
1802	282126701	Heat Sink x 2
1804	288816003	Bracket x 4
1806	282016007	Bracket x 4
1818	51380306P	P.H. Tap Screw x 8
1820	51380306P	P.H. Tap Screw x 16
H001	HT403152D	Transistor, 2SD315D or E x2
H002	HT403152D	Transistor, 2SD315D or E x2
H003	HT403152D	Transistor, 2SD315D or E x2
H004	HT403152D	Transistor, 2SD315D or E x2
P700	YD2888006 ZZ2888006	P.W. Board, Main AMP x2 P.W. Board Ass'y x2
RESISTORS		
All resistors are ±5% and ¼W, unless otherwise indicated.		
R701	RT0510414	100KΩ x 2
R702	RT0510414	100KΩ x 2
R703	RT0510214	1KΩ x 2
R704	RT0510214	1KΩ x 2
R705	RT0524314	24KΩ x 2
R706	RT0524314	24KΩ x 2
R707	RT0510414	100KΩ x 2
R708	RT0510414	100KΩ x 2
R709	RT0582114	820Ω x 2
R710	RT0582114	820Ω x 2
R711	RT0582214	8.2KΩ x 2
R712	RT0582214	8.2KΩ x 2
R713	RT0518314	18KΩ x 2
R714	RT0518314	18KΩ x 2
R715	RA0502017	Trimming, 5KΩ (B) x 2
R716	RA0502017	Trimming, 5KΩ (B) x 2
R717	RT0515314	15KΩ x 2
R718	RT0515314	15KΩ x 2
R719	RT0510414	100KΩ x 2
R720	RT0510414	100KΩ x 2
R721	RT0510214	1KΩ x 2
R722	RT0510214	1KΩ x 2
R723	RT0511314	11KΩ x 2
R724	RT0511314	11KΩ x 2
R725	RT0510014	10Ω x 2
R726	RT0510014	10Ω x 2
R727	RT0518214	1.8KΩ x 2
R728	RT0518214	1.8KΩ x 2
R729	RT0533214	3.3KΩ x 2
R730	RT0533214	3.3KΩ x 2
R731	RT0518114	180Ω x 2
R732	RT0518114	180Ω x 2
R733	RT0510114	100Ω x 2
R734	RT0510114	100Ω x 2

REF. DESIG.	MARANTZ PART NO.	DESCRIPTION
R735	RA0501010	Trimming, 500Ω (B) x 2
R736	RA0501010	Trimming, 500Ω (B) x 2
R737	GF0510214	1KΩ x 2
R738	GF0510214	1KΩ x 2
R739	RT0547214	4.7KΩ x 2
R740	RT0547214	4.7KΩ x 2
R741	GF0510214	1KΩ x 2
R742	GF0510214	1KΩ x 2
R743	GF0518114	180Ω x 2
R744	GF0515114	150Ω x 2
R745	GF0510114	100Ω x 2
R746	GF0515114	150Ω x 2
R747	GF0575014	75Ω x 2
R748	GF0582014	82Ω x 2
R749	GF0556014	56Ω x 2
R750	GF0568014	68Ω x 2
R751	RC1010012	10Ω ± 10%, ½W x 2
R752	RC1010012	10Ω ± 10%, ½W x 2
R753	GF0533114	330Ω x 2
R754	GF0533114	330Ω x 2
R755	GF0522014	22Ω x 2
R756	GF0522014	22Ω x 2
R757	GF0533114	330Ω x 2
R758	GF0533114	330Ω x 2
R759	RW1000503	0.5Ω ± 10%, 3W x 2
R760	RW1000503	0.5Ω ± 10%, 3W x 2
R761	RW1000503	0.5Ω ± 10%, 3W x 2
R762	RW1000503	0.5Ω ± 10%, 3W x 2
R763	RJ1010101	100Ω ± 10%, 1W x 2
R764	RJ1010101	100Ω ± 10%, 1W x 2
R765	RC1047012	47Ω ± 10%, ½W x 2
R766	RC1047012	47Ω ± 10%, ½W x 2
R767	RC1005612	5.6Ω ± 10%, ½W x 2
R768	RC1005612	5.6Ω ± 10%, ½W x 2
R769	GF0510014	10Ω x 2
R770	GF0510014	10Ω x 2
R771	RC1068112	680Ω ± 5%, ½W x 2
R772	RT0510314	10KΩ x 2
R773	RT0510214	1KΩ x 2
L701	LC2272001	COILS Choke Coil x 2
L702	LC2272001	Choke Coil x 2
F701	FS1030006	MISCELLANEOUS Fuse, 3A x 2
F702	FS1030006	Fuse, 3A x 2
C701	DF1722405	CAPACITORS Film, 0.22μF ± 20% x 2
C702	DF1722405	Film, 0.22μF ± 20% x 2
C703	DF1733405	Film, 0.33μF ± 20% x 2
C704	DF1733405	Film, 0.33μF ± 20% x 2
C705	DD1582001	Ceramic, 82PF ± 5% x 2
C706	DD1582001	Ceramic, 82PF ± 5% x 2
C707	EA2260109	Electroly, 22μF, 10V x 2
C708	EA2260109	Electroly, 22μF, 10V x 2
C709	EA4760509	Electroly, 47μF, 50V x 2
C710	EA4760509	Electroly, 47μF, 50V x 2
C711	DD1210001	Ceramic, 10PF ± 1PF x 2
C712	DD1210001	Ceramic, 10PF ± 1PF x 2
C713	DD1540001	Ceramic, 40PF ± 5% x 2
C714	DD1540001	Ceramic, 40PF ± 5% x 2
C715	DF1768301	Film, 0.068μF ± 20% x 2

REF. DESIG.	MARANTZ PART NO.	DESCRIPTION
C716	DF1768301	Film, 0.068μF ± 20% x 2
C717	DF1730301	Film, 0.03μF ± 20% x 2
C718	DF1730301	Film, 0.03μF ± 20% x 2
C719	DF1739305	Film, 0.039μF ± 20% x 2
C720	DF1727305	Film, 0.027μF ± 20% x 2
C721	DD1530101	Ceramic, 300PF ± 10% x 2
C722	DD1530101	Ceramic, 300PF ± 10% x 2
C723	DF1710405	Film, 0.1μF ± 20% x 2
C724	DF1710405	Film, 0.1μF ± 20% x 2
C725	DF1722405	Film, 0.22μF ± 20% x 2
C726	DF1722405	Film, 0.22μF ± 20% x 2
C727	EA4760259	Electroly, 47μF, 25V x 2
C728	EA4760259	Electroly, 47μF, 25V x 2
C729	EA4750359	Electroly, 4.7μF, 35V x 2
C730	DK1615201	Ceramic, 0.0015μF ± 10% x 2
C731	DK1615201	Ceramic, 0.0015μF ± 10% x 2
C732	DD1530101	Ceramic, 300PF ± 10% x 2
C733	DD1530101	Ceramic, 300PF ± 10% x 2
H701	HT106401L	SEMICONDUCTORS Transistor, 2SA640 (L) x 2
H702	HT106401L	Transistor, 2SA640 (L) x 2
H703	HT106401L	Transistor, 2SA640 (L) x 2
H704	HT106401L	Transistor, 2SA640 (L) x 2
H705	HT315091P	Transistor, 2SC1509 (P) x 2
H706	HT315091P	Transistor, 2SC1509 (P) x 2
H707	HT309451Q	Transistor, 2SC945 (Q) x 2
H708	HT309451Q	Transistor, 2SC945 (Q) x 2
H709	HT107331Q	Transistor, 2SA733 (Q) x 2
H710	HT107331Q	Transistor, 2SA733 (Q) x 2
H711	HT315091P	Transistor, 2SC1509 (P) x 2
H712	HT315091P	Transistor, 2SC1509 (P) x 2
H713	HT107771P	Transistor, 2SA777 (P) x 2
H714	HT107771P	Transistor, 2SA777 (P) x 2
H715	HD3003009	Diode, WZ-177 x 2
H716	HV0000205	Varistor, M8513A-0 x 2
H717	HV0000205	Varistor, M8513A-0 x 2
H718	HH0000912	Thermistor, 22D47 x 2
H719	HH0000912	Thermistor, 22D47 x 2
H720	HD2000121	Diode, 1S2473 (C) x 2
H721	HD2000121	Diode, 1S2473 (C) x 2
H722	HD2000121	Diode, 1S2473 (C) x 2
H723	HD2000121	Diode, 1S2473 (C) x 2
H724	HD1000105	Diode, 1N60 x 2
H725	HD1000105	Diode, 1N60 x 2
H726	HD1000105	Diode, 1N60 x 2
H727	HD1000105	Diode, 1N60 x 2
J701	YP1000114	MISCELLANEOUS Plug x 2
J724	YP1000114	Plug x 2
J725	YJ0800017	Socket x 2
J728	YJ0800017	Socket x 2
J729	YP1000114	Plug x 2
P800	YD2886006 ZZ2888106	P.W. Board, Power Supply P.W. Board Ass'y

REF. DESIG.	MARANTZ PART NO.	DESCRIPTION
RESISTORS		
R801	RA0502010	Trimming, 5K Ω (B)
R802	GJ0527102	270 Ω \pm 5%, 2W
R803	RT0527314	27K Ω \pm 5%, 1/4W
R804	RT0536314	36K Ω \pm 5%, 1/4W
R805	GJ0524103	240 Ω \pm 5%, 3W
R806	RT0510314	10K Ω \pm 5%, 1/4W
R807	RT0522214	2.2K Ω \pm 5%, 1/4W
R808	RT0562214	6.2K Ω \pm 5%, 1/4W
R809	GJ0547003	47 Ω \pm 5%, 3W
R810	RC1010112	100 Ω \pm 10%, 1/2W
R811	RW1000503	0.5 Ω \pm 10%, 3W
R812	RC1039012	39 Ω \pm 10%, 1/2W
CAPACITORS		
C801	EA3350509	Electroly, 3.3 μ F, 50V
C802	EA4770169	Electroly, 470 μ F, 16V
C803	EA3370509	Electroly, 330 μ F, 50V
C804	EA3370631	Electroly, 330 μ F, 63V
C805	EA4770109	Electroly, 470 μ F, 10V
C806	DK1840302	Ceramic, 0.04 μ F +100%, -0%
C807	DF1747305	Film, 0.047 μ F \pm 20%
C808	DK1810351	Ceramic, 0.01 μ F +100%, -0%
SEMICONDUCTORS		
H801	HT403152B	Transistor, 2SD315 (C or D)
H802	HT309451P	Transistor, 2SC945 (P)
H803	HT309451Q	Transistor, 2SC945 (Q)
H804	HD3002109	Diode, BZ-140
H805	HD2000413	Diode, S1B01-O2
H806	HD2000413	Diode, S1B01-O2
H807	HD2000413	Diode, S1B01-O2
H808	HD2000413	Diode, S1B01-O2
H809	HD2000413	Diode, S1B01-O2
H810	HD2000121	Diode, 1S2473
MISCELLANEOUS		
J801	YP1000113	Plug
J814		
J816	YP1000099	Plug
J818		
1431	273026702	Heat Sink
1534	53110303E	Nut x 2
5036	54050300R	T.L. Washer OR x 2
0903	288616050	Bracket K
0909	288612201	Sticker
0913	257710602	Bearing
0914	141511801	Spacer
0915	51040306A	F.H.M. Screw x 2
0920	51100306S	B.H.M. Screw x 3
0927	51100305A	B.H.M. Screw x 2
0933	51102604A	B.H.M. Screw x 2
0934	51102604A	B.H.M. Screw x 2
0935	288610903	Shield

REF. DESIG.	MARANTZ PART NO.	DESCRIPTION
1003	281816003	Bracket
1004	281816004	Bracket
1005	51100406A	B.H.M. Screw x 4
1011	51102605A	B.H.M. Screw x 6
1012	51060305A	P.H.M. Screw x 8
1131	51042608A	F.H.M. Screw x 2
1221	51570306B	P.H. Tape Screw x 2
1222	54050300R	T.L. Washer OR x 2
1616	51470306A	B.H.M. Screw S x 2
1704	285326901	Protector
1708	281912004	Insulator
1714	51570305B	P.H. Tapt Screw x 2
M004	IM1104209	DC Meter
M005	IM1104202	DC Meter
1225	288610701	Sheet x 2
C004	EA1070109	Electroly Cap., 100 μ F, 10V
1721	287105302	Cover x 2
PT01	YD2886011 ZZ2886011	P.W. Board, Tape Mon. SW P.W. Board Ass'y
ST01	SP0802001	Push Switch, Tape Mon.
RESISTORS		
All resistors are \pm 5% and 1/4W.		
RT01	RT0510214	1K Ω
RT02	RT0510214	1K Ω
RT03	RT0510214	1K Ω
RT04	RT0510214	1K Ω
MISCELLANEOUS		
JT01	YP1000113	Plug
JT06		
S001	SR1506002	Rotary Switch, Selector
S002	SR1205002	Rotary Switch, Mode
S003	SR2505001	Rotary Switch, Dolby
J011	YJ0700006	Jack, SQ
1406	285110450	Retainer K
1410	51100310S	B.H.M. Screw x 2
1411	59030805P	Fiber Washer x 2
1412	203912001	Insulator
P500	YD2886012 ZZ2886012	P.W. Board, Vari. Matrix. P.W. Board Ass'y

REF. DESIG.	MARANTZ PART NO.	DESCRIPTION
		RESISTORS All resistors are $\pm 5\%$ and $\frac{1}{4}W$, unless otherwise indicated.
R501	RT0515414	150K Ω
R502	RT0515414	150K Ω
R503	RT0556314	56K Ω
R504	RT0556314	56K Ω
R505	RT0522414	220K Ω
R506	RT0522414	220K Ω
R507	RT0533414	330K Ω
R508	RT0533414	330K Ω
R509	RT0556214	5.6K Ω
R510	RT0556214	5.6K Ω
R511	RT0556214	5.6K Ω
R512	RT0556214	5.6K Ω
R513	RT0568214	6.8K Ω
R514	RT0568214	6.8K Ω
R515	RT0568214	6.8K Ω
R516	RT0568214	6.8K Ω
R517	RT0547314	47K Ω
R518	RT0547314	47K Ω
R519	RT0547314	47K Ω
R520	RT0547314	47K Ω
R521	RT0520314	20K Ω
R522	RT0520314	20K Ω
R523	RT0533414	330K Ω
R524	RT0533414	330K Ω
R525	RT0510414	100K Ω
R526	RT0510414	100K Ω
R527	RT0556214	5.6K Ω
R528	RT0556214	5.6K Ω
R529	RT0522314	22K Ω
R530	RT0522314	22K Ω
R531	RT0522114	220 Ω
R532	RM0503054	Variable, 50K Ω (B)
		MISCELLANEOUS
J501 { J506	YP1000113	Plug
		CAPACITORS
C501	EE4740501	Electroly, 0.47 μ F, 50V
C502	EE4740501	Electroly, 0.47 μ F, 50V
C503	EE3350501	Electroly, 3.3 μ F, 50V
C504	EE3350501	Electroly, 3.3 μ F, 50V
C505	EE3350501	Electroly, 3.3 μ F, 50V
C506	EE3350501	Electroly, 3.3 μ F, 50V
C507	DF1647305	Film, 0.047 μ F $\pm 10\%$
C508	DF1647305	Film, 0.047 μ F $\pm 10\%$
C509	DF1647305	Film, 0.047 μ F $\pm 10\%$
C510	DF1647305	Film, 0.047 μ F $\pm 10\%$
C511	EE3350501	Electroly, 3.3 μ F, 50V
C512	EE3350501	Electroly, 3.3 μ F, 50V
C513	EA1070109	Electroly, 100 μ F, 10V
C514	EA1070109	Electroly, 100 μ F, 10V
C515	EE3350501	Electroly, 3.3 μ F, 50V
C516	EE3350501	Electroly, 3.3 μ F, 50V
C517	DD1650001	Ceramic, 50PF $\pm 10\%$
C518	DD1650001	Ceramic, 50PF $\pm 10\%$
C519	DF1610205	Film, 0.001 μ F $\pm 20\%$
C520	DF1610205	Film, 0.001 μ F $\pm 20\%$
C521	EA1070359	Electroly, 100 μ F, 35V

REF. DESIG.	MARANTZ PART NO.	DESCRIPTION
		SEMICONDUCTORS
H501	HT313272A	Transistor, 2SC1327 (S or T)
H502	HT313272A	Transistor, 2SC1327 (S or T)
H503	HC1000705	IC, TA7122 AP, B or C
H504	HC1000705	IC, TA7122 AP, B or C
PF01	YD2886002 ZZ2886102	P.W. Board Tone P.W. Board Ass'y
		RESISTORS All resistors are $\pm 5\%$ and $\frac{1}{4}W$, unless otherwise indicated.
RF01	RU0204001	Variable, 200K Ω (B)
RF02	RU0204001	Variable, 200K Ω (B)
RF03	RT0527314	27K Ω
RF04	RT0527314	27K Ω
RF05	RT0527314	27K Ω
RF06	RT0527314	27K Ω
RF07	RT0527314	27K Ω
RF08	RT0527314	27K Ω
RF09	RT0527314	27K Ω
RF10	RT0527314	27K Ω
RF11	RT0510414	100K Ω
RF12	RT0510414	100K Ω
RF13	RT0510414	100K Ω
RF14	RT0510414	100K Ω
RF15	RT0510314	10K Ω
RF16	RT0510314	10K Ω
RF17	RT0510314	10K Ω
RF18	RT0510314	10K Ω
RF19	RT0543414	43K Ω
RF20	RT0543414	43K Ω
RF21	RT0543414	43K Ω
RF22	RT0543414	43K Ω
		CAPACITORS
CF01	DF1622305	Film, 0.022 μ F $\pm 10\%$
CF02	DF1622305	Film, 0.022 μ F $\pm 10\%$
CF03	DF1622305	Film, 0.022 μ F $\pm 10\%$
CF04	DF1622305	Film, 0.022 μ F $\pm 10\%$
CF05	DF1622305	Film, 0.022 μ F $\pm 10\%$
CF06	DF1622305	Film, 0.022 μ F $\pm 10\%$
CF07	DF1622305	Film, 0.022 μ F $\pm 10\%$
CF08	DF1622305	Film, 0.022 μ F $\pm 10\%$
CF09	DD1520101	Ceramic, 200PF $\pm 5\%$
CF10	DD1520101	Ceramic, 200PF $\pm 5\%$
CF11	DD1520101	Ceramic, 200PF $\pm 5\%$
CF12	DD1520101	Ceramic, 200PF $\pm 5\%$
		MISCELLANEOUS
JF01 { JF12	YP1000113	Plug
J012	YJ0100065	Jack, Head Phone
J013	YJ0100065	Jack, Head Phone
0918	288612003	Insulator
S008	SP0201009	Push Switch, Meter L-R
R001	RG0503002	Variable Resistor, 50K Ω (B) VR

REF. DESIG.	MARANTZ PART NO.	DESCRIPTION
R002	RK0504010	Variable Resistor, Dolby Play Cal.
R003	RK0504010	Variable Resistor, Dolby Play Cal.
R004	RK0504010	Variable Resistor, Dolby Rec. Cal.
R005	RK0504010	Variable Resistor, Dolby Rec. Cal.
0926	288616010	Bracket
R013	RT0539214	Resistor, 3.9K Ω \pm 5%, $\frac{1}{4}$ W
7436	62031650W	Lug
S007	SP0801001	Push Switch, 400Hz Tone
PG01	YD2886003 ZZ2886003	P.W. Board, Balance P.W. Board Ass'y
RESISTORS		
RG01	RT0533214	3.3K Ω \pm 5%, $\frac{1}{4}$ W
RG02	RT0533214	3.3K Ω \pm 5%, $\frac{1}{4}$ W
RG03	RT0533214	3.3K Ω \pm 5%, $\frac{1}{4}$ W
RG04	RT0533214	3.3K Ω \pm 5%, $\frac{1}{4}$ W
RG05	RX0503006	Variable, 20K Ω (G)
RG06	RX0503006	Variable, 20K Ω (G)
RG07	RS0503017	Variable, 20K Ω (G)
MISCELLANEOUS		
JG01 } JG09	YP1000113	Plug
PS01	YD2886005 ZZ2886005	P.W. Board, Switch P.W. Board Ass'y
SS01	SP0706001	Push Switch
RESISTORS		
All resistors are \pm 5% and $\frac{1}{4}$ W.		
RS01	RT0515314	15K Ω
RS02	RT0515314	15K Ω
RS03	RT0515314	15K Ω
RS04	RT0515314	15K Ω
RS05	RT0533214	3.3K Ω
RS06	RT0533214	3.3K Ω
RS07	RT0533214	3.3K Ω
RS08	RT0533214	3.3K Ω
RS09	RT0547214	4.7K Ω
RS10	RT0547214	4.7K Ω
RS11	RT0547214	4.7K Ω
RS12	RT0547214	4.7K Ω
RS13	RT0510514	1M Ω
RS14	RT0510514	1M Ω
RS15	RT0510514	1M Ω
RS16	RT0510514	1M Ω
CAPACITORS		
CS01	DF1610205	Film, 0.001 μ F \pm 10%
CS02	DF1610205	Film, 0.001 μ F \pm 10%
CS03	DF1610205	Film, 0.001 μ F \pm 10%
CS04	DF1610205	Film, 0.001 μ F \pm 10%
CS05	EM1040251	Electroly, 0.1 μ F, 25V
CS06	EM1040251	Electroly, 0.1 μ F, 25V
CS07	EM1040251	Electroly, 0.1 μ F, 25V
CS08	EM1040251	Electroly, 0.1 μ F, 25V
CS09	DF1682205	Film, 0.0083 μ F \pm 10%

REF. DESIG.	MARANTZ PART NO.	DESCRIPTION
CS10	DF1682205	Film, 0.0083 μ F \pm 10%
CS11	DF1682205	Film, 0.0083 μ F \pm 10%
CS12	DF1682205	Film, 0.0083 μ F \pm 10%
MISCELLANEOUS		
JS01 } JS08	YP1000113	Plug
1203	288627401	Reflector
1205	288626251	Pulley K
1211	51100305A	B.H.M. Screw x 2
1212	54050300R	T.L. Washer OR x 2
1214	288627102	Holder
1215	51570305B	P.H. Tapt Screw x 2
1217	51480306A	B.H.M. Screw F x 2
J018	YJ0800019	Socket, Lamp
J019	YJ0800019	Socket, Lamp
M002	IN1008007	Lamp, Meter
M003	IN1008007	Lamp, Meter
PY01	YD2888002 ZZ2888002	P.W. Board Function Lamp P.W. Board Ass'y
RY01	RC1002712	Resistor 2.7 Ω \pm 10%, $\frac{1}{2}$ W
MISCELLANEOUS		
MY01	IN1006301	Lamp, Dolby
MY02	IN1006301	Lamp, FM
MY03	IN1006301	Lamp, AM
MY04	IN1006301	Lamp, Stereo
MY05	IN1006302	Lamp, Quad
MY06	IN1006301	Lamp, Tape 1
MY07	IN1006301	Lamp, Phone
MY08	IN1006301	Lamp, Aux
MY09	IN1006301	Lamp, Tape 2
JY01 } JY15	YP1000113	Plug
PZ01	YD2886016 ZZ2886016	P.W. Board, Dial Lamp P.W. Board Ass'y
MISCELLANEOUS		
MZ01	IN1008007	Lamp, Dial
MZ02	IN1008007	Lamp, Dial
MZ03	IN1008007	Lamp, Dial
MZ04	IN1008007	Lamp, Dial
MZ05	IN1008007	Lamp, Dial
JZ01 } JZ10	YJ0800017	Socket

REF. DESIG.	MARANTZ PART NO.	DESCRIPTION
JZ11 ? JZ12	YP1000113	Plug
1103	287127401	Reflector
1105	287127101	Holder
1106	51570305B	P.H. Tapt Screw x 2
1108	288627101	Holder
1109	51570305B	P.H. Tapt Screw x 2
1111	51100305A	B.H.M. Screw x 2
1113	51480306A	B.H.M. Screw F x 2
1116	203912001	Insulator
8336	54050300R	T.L. Washer OR x 2
1121	287105102	Guide
1123	288626252	Pulley K
1128	51100305A	B.H.M. Screw x 2
8436	62031650W	Lug
8437	54050300R	T.L. Washer OR
1606	285310650	Bearing K
1611	51640410D	Set Screw C.P.
1612	54040402N	Spring Washer
1613	53110403E	Hexagon Nut
0931	285310901	Shield
0932	282112001	Insulator
8636	62031650W	Lug
8637	62031650W	Lug
8638	62031650W	Lug
0513	51100308S	B.H.M. Screw x 20
0514	53110303E	Hexagon Nut x 20
0516	53228059E	Nut x 3
0522	54050400R	T.L. Washer OR
0532	145525903	Bush
0533	145525903	Bush
0616	51100306S	B.H.M. Screw x 3
0620	51100304S	B.H.M. Screw x 2
0622	51100304S	B.H.M. Screw x 2
0625	281805501	Collar x 2
0631	51100312S	B.H.M. Screw x 2
0632	53110303E	Hexagon Nut x 2
J001	YT0208002	Terminal, 8P
J002	YT0208002	Terminal, 8P
J003	YT0204003	Terminal, 4P

REF. DESIG.	MARANTZ PART NO.	DESCRIPTION
J004	YT0202007	Terminal, 2P
J005	YT0201006	Terminal, 1P
J006	YT0304005	Terminal, SPK
J007	YT0304005	Terminal, SPK
J008	YT0304005	Terminal, SPK
J009	YT0304005	Terminal, SPK
J010	YT0104004	Terminal, ANT
J017	YJ0800012	Socket, Fuse Holder
J020	YT0101003	Terminal, Ground
J022	YL0102003	Terminal, 2P
W001	YC0240010	AC Cord
F001	FS1040005	Fuse, 4A
G001	BF1040001	Printed Compo.
L003	LB3007526	Balun Coil, FM
L004	LC1332002	Choke Coil, AM
C008	DF1722380	Film Cap. 0.022 μ F \pm 20%
R009	RK0203016	Variable Resistor, 20K Ω (B) Muting
RC05	RK0203030	Variable Resistor, 20K Ω
RC06	RK0203030	Variable, 20K Ω VR FM PRE-SET
S006	SS0802007	Slide Switch, Remote Control
PC01	YD2886014 ZZ2888114	P.W. Board, Dolby Remote P.W. Board Ass'y
SC01	SS0202017	Slide Switch
RC01	RT0522414	220K Ω \pm 5%, $\frac{1}{4}$ W
RC02	RT0522414	220K Ω \pm 5%, $\frac{1}{4}$ W
RC03	RT0510314	10K Ω \pm 5%, $\frac{1}{4}$ W
RC04	RT0510314	10K Ω \pm 5%, $\frac{1}{4}$ W
CC01	DF1518205	Film, 0.0018 μ F \pm 5%
CC02	DF1518205	Film, 0.0018 μ F \pm 5%
JC01 ? JC12	YP1000113	Plug
L002	LF1120024	Ant Coil, AM
0602	257816052	Bracket K
0607	281927103	Holder
0609	51100310S	B.H.M. Screw x 2
0610	53110301E	Hexagon Nut x 2
0612	51100308S	B.H.M. Screw x 2
0613	53110301E	Hexagon Nut x 2

REF. DESIG.	MARANTZ PART NO.	DESCRIPTION
L005	LC1154002	Choke Coil
J014	YJ1100012	Jack
0626	285116007	Bracket
0628	51100306S	B.H.M. Screw x 2
0629	53110303E	Hexagon Nut x 2
R006	RC1022512	Resistor, 2.2MΩ ± 10%, ½W
9436	62031650W	Lug
C001	DK1710301	Ceramic Cap. 0.01μF ± 20%
9437	62031650W	Lug
S004	SR0702001	Rotary Switch, BTL
R010	RK0503009	Variable Resistor, 50KΩ (B) Mut. Adj.
1413	288816004	Bracket
H007	HD2000510	Diode, 5B2
C005	DK1810351	Ceramic Cap. 0.01μF +100%, -0%
J021	YL0104014	Terminal
J023	YL0103019	Terminal, 3P
C006	EA2270509	Electroly Cap., 220μF, 50V
1710	288830201	Dial
0911	285610701	Sheet
0451	62031650W	Lug
1503	138200503	Clamper x 4
1515	282100501	Clamper x 2
W002	YW2888001	Wire Material
W003	YX2888001	Wire Material
W004	YW2886002	Wire Material
W005	YX2888101	Wire Material
W006	YW2888101	Wire Material
0411	275905701	Leg x 4
0412	51490410S	B.H.M. Screw FS x 4
1303	288810550	Chassis K
1313	288810101	Support x 4
1317	51100304S	B.H.M. Screw x 4
1318	51100306S	B.H.M. Screw x 3
1319	51100306S	B.H.M. Screw x 2
1320	51100306S	B.H.M. Screw x 4
1322	51100306S	B.H.M. Screw x 2
1323	51100306S	B.H.M. Screw x 2
1324	51100306S	B.H.M. Screw x 6
1326	288810903	Shield
1327	288810102	Support x 4

REF. DESIG.	MARANTZ PART NO.	DESCRIPTION
1331	51570306B	P.H. Tapt Screw x 4
1332	51570306B	P.H. Tapt Screw x 8
1333	51570306B	P.H. Tapt Screw x 2
1334	51570306B	P.H. Tapt Screw x 10
1335	51570310B	P.H. Tapt Screw x 2
1402	285610902	Shield
1403	285610102	Support x 4
1404	281810107	Support
1405	51060304E	P.H.M. Screw x 5
1409	51100303S	B.H.M. Screw x 2
1414	51570305B	P.H. Tapt Screw x 2
1416	285310102	Support x 2
1417	54040402N	Spring Washer x 2
1419	51470512A	B.H.M. Screw FS x 4
1420	53110501A	Hexagon Nut x 4
1421	54020501A	Flat Washer P x 4
1422	54040502A	Spring Washer x 4
1424	281805601	Buffer x 2
1435	51100304S	B.H.M. Screw x 2
1426	51570305B	P.H. Tapt Screw x 2
1427	288610902	Shield
1429	288612004	Insulator
1430	51570305B	P.H. Tapt Screw x 2
1051	138200503	Clamper x 6
1504	59030805P	Fiber Washer x 2
1052	54050300R	T.L. Washer OR x 6
1509	62031650W	Lug x 2
1511	51570306B	P.H. Tapt Screw x 10
1513	51570306B	P.H. Tapt Screw x 10
1906	138200503	Clamper x 2
C002	EC1090351	Electroly Cap., 10000μF, 35V
C003	EC1090351	Electroly Cap., 10000μF, 35V
L001	TS6050302	Power Transformer
0202	285325701	Lid
0203	257711803	Spacer x 4
0204	285605601	Buffer x 4
0217	285015401	Knob x 3
0218	288615403	Knob x 8
0219	281815401	Knob x 2
0220	288615401	Knob x 4
0221	281815403	Knob x 5
0232	288615402	Knob
1602	285011202	Shaft
1603	54040402N	Spring Washer
0302	288826501	Indicator
0309	51100305S	B.H.M. Screw x 2

REF. DESIG.	MARANTZ PART NO.	DESCRIPTION
0311	257886101	Label, UL Caution
0312	257886102	Label, Do not Remove
0313	257886103	Label, See Marking
0314	250626506	Indicator, Do not use as
0323	951110102	Label, UL
0329	951091102	Label, Factory Cord
0402	51122608B	T.H.M. Screw x 4
0404	51100406S	B.H.M. Screw x 9
0406	51480406S	B.H.M. Screw F x 4
0421	289205502	Collar
0816	56382540G	Eyelet
1702	286726901	Protector
1706	51570305B	P.H. Tapt Screw x 2
1719	51100305S	B.H.M. Screw x 2
1329	288611801	Spacer
1911	288810902	Shield
1912	51100305S	B.H.M. Screw x 4
1913	51570305B	P.H. Tapt Screw x 2
2002	288885101	Instructions
2009	28885601	Schematic Diagram
2016	281885104	Instructions
2017	281885108	Instructions
2021	257785450	Guarantee Card K
2104	288880105	Packing Case
2105	288880106	Packing Case
2107	288680302	Partitioner
2108	288680303	Partitioner
2112	901483838	Polyethylen Bag
2114	901302501	Polyethylen Bag x 2
2117	102980401	Sleeve
2119	273182101	Siicagel x 2
2120	281905601	Buffer
2122	285125703	Lid
2123	285386101	Label
2124	51216059E	Screw x 4
2131	ZA0200007	Ext. Antenna
2202	952281501	Serial NO Card x 4

TECHNICAL SPECIFICATIONS

FM SECTION:

Tuning Frequency Range.....	88 – 108 MHz
IHF M Usable Sensitivity	2.2 μ V at 30 dB
	50 μ V at 70 dB
IHF Selectivity.....	more than 60 dB
Capture Ratio	1.5 dB
Image Rejection Ratio at 106 MHz	more than 60 dB
Total Harmonic Distortion (Mono)	0.3%
Total Harmonic Distortion (Stereo).....	0.4%
Frequency Response (ref. 75 μ sec. de-emphasis)	\pm 1 dB, from 30 Hz to 15 KHz
Stereo Separation at 1 KHz	40 dB, 30 dB at 15 KHz
Quadradial Output (400 Hz 75 KHz dev.)	300 mV, 15 Kohms

AM SECTION:

Tuning Frequency Range.....	540 to 1605 KHz
Usable Sensitivity	25 μ V
Selectivity	1000 KHz, 26 dB
Image Rejection Ratio at 1400 KHz	70 dB
Bandwidth (–6 dB)	7 KHz

AUDIO SECTION:

Input Sensitivity and Impedance – Phono	2.2 mV, 47 Kohms
– High level.....	150 mV
Intermodulation Distortion below rated power output (SMPTE)	Less than 0.5%
	Nominal 0.3%
Damping Factor	2 channel : 20 at 20 Hz
	4 channel : 40 at 20 Hz
Rated Continuous (RMS) Output	80W at 8 ohms (40W x 2)
all channels operating simultaneously at 20 Hz	68W at 8 ohms (17W x 4)
to 20 KHz for nominal harmonic distortion	

GENERAL:

Power Requirements	120V, AC
	50/60 Hz
Power Consumption— at maximum power output	270 watts
– idling (no signal)	40 watts
Dimensions – Panel Width	17 21/64 Inches
– Panel Height	5 25/64 Inches
– Depth	14 3/8 Inches
– Width (Packed for Shipment).....	22 1/4 Inches
– Height (Packed for Shipment)	10 1/2 Inches
– Depth (Packed for Shipment).....	19 1/2 Inches
Weight – Unit alone	34.1 lbs
– Packed for Shipment	43 lbs

* These specifications and exterior designs may be changed for improvement without advance notice.

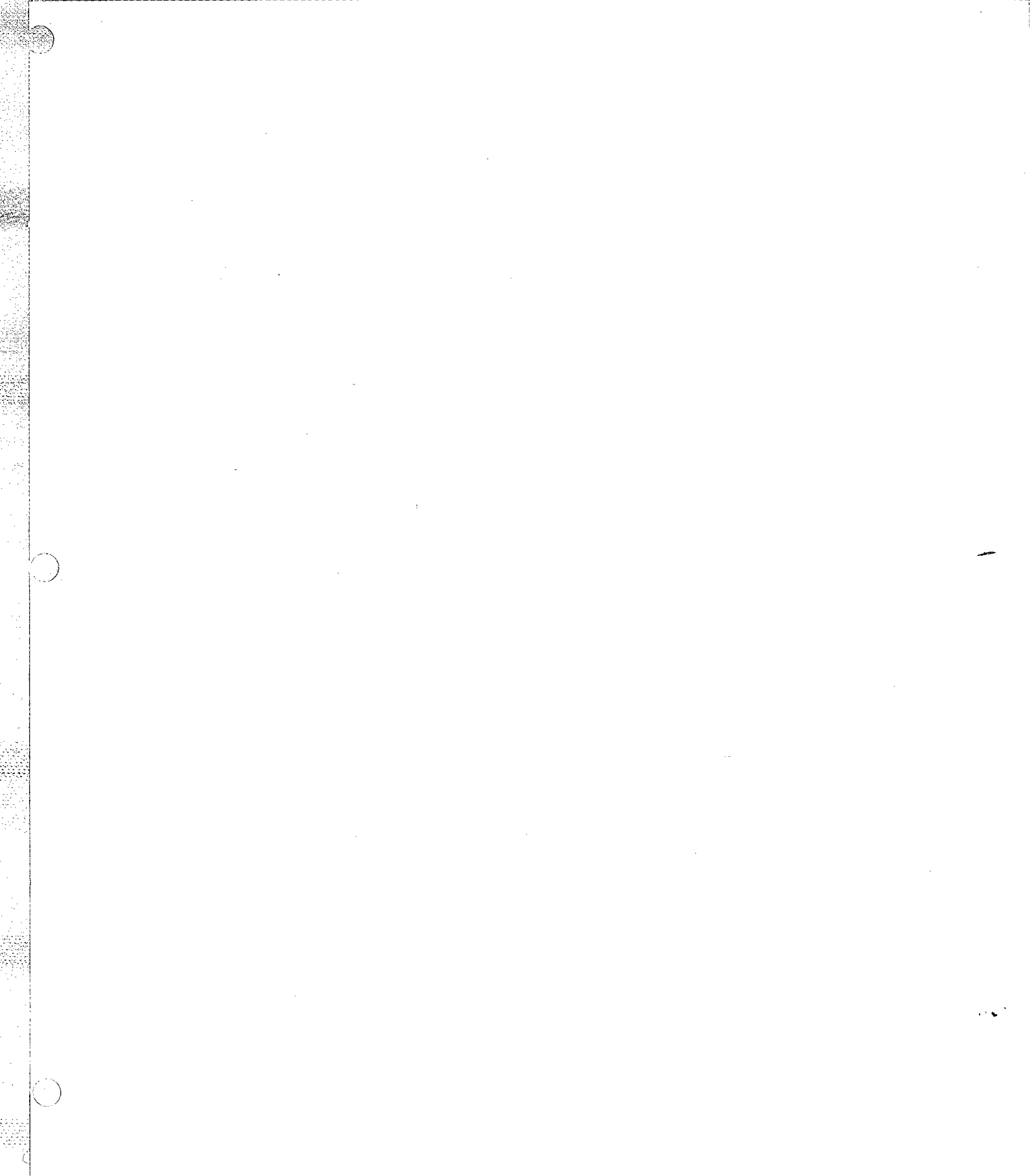
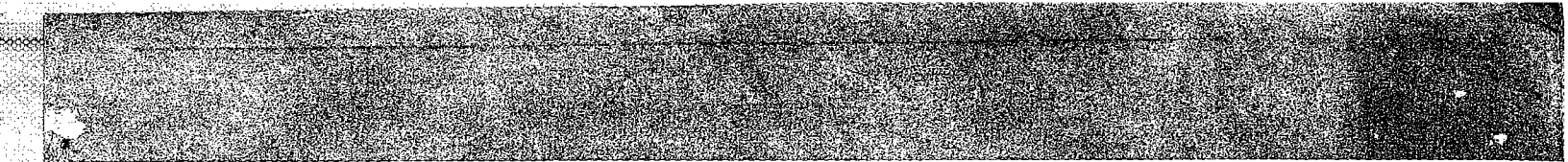



marantz

MARANTZ CO., INC. • P.O. BOX 99 • SUN VALLEY, CALIFORNIA • 91352

A WHOLLY-OWNED SUBSIDIARY OF SUPERSCOPE INC., SUN VALLEY, CALIFORNIA 91352