

QUAD 44

service data

Quad Electroacoustics Co. Ltd.
St Peters Road, Huntingdon, Cambs, PE18 7DB, England
Telephone: 0480 52561 Telex 32348 QUAD G

QUAD 44 service data

Contents	page
Introduction	3
Test Procedure	3
Test Equipment	3
Anti RIAA Network	5
Fault Finding	8
44 Functional Block Diagram	9
Input Selector M12428:	10
ISS 5 Overlay Diagram	10
ISS 4 & 5 Circuit Diagram	10
Modifications	11
ISS 4 & 5 Components List	11
Mother Board and Power Supply M12436	12
ISS 4 Overlay Diagram	12
ISS 4 Circuit Diagram	13
ISS 5 Overlay Diagram	14
ISS 5 Circuit Diagram	15
Modifications	16
Components List	17
Disc Input M12515:	18
ISS 4 Overlay Diagram	18
ISS 4 Circuit Diagram	18
ISS 5 Overlay Diagram	19
ISS 5 Circuit Diagram	19
Modifications	20
Components List	20
Moving Coil Disc Input M12542:	21
ISS 3 Overlay Diagram	21
ISS 3 Circuit Diagram	21
Modifications	22
Components List	22
Tape Input M12496:	23
ISS 3 Overlay Diagram	23
ISS 3 Circuit Diagram	23
Modifications	24
Components List	24
Radio and Auxiliary Input M12511:	25
ISS 1 Radio Overlay Diagram	25
ISS 2 Radio Overlay Diagram	26
ISS 1 and 2 Radio Circuit Diagram	25, 26
ISS 2 Auxiliary Overlay Diagram	27
ISS 2 Auxiliary Circuit Diagram	27
Modifications	28
Components List	28
Tone Control Board M12512:	29
ISS 8 Circuit Diagram	29
ISS 8 Overlay Diagram	30
ISS 9 Circuit Diagram	31
ISS 9 Overlay Diagram	32
Modifications	33
Components List	34
Miscellaneous Modifications	35
Miscellaneous Components List	36
Completed Sub Assemblies List	36

introduction

The Quad 44 control unit accepts the outputs from a variety of sources, pickup, tape recorder, radio tuner, and amplifies the selected source up to amplifier input level. At the same time the Quad 44 provides the listener with the means to compensate for certain effects of the listening environment and programme balance. The results obtained from almost any programme material can be improved by intelligent use of the Tilt, Bass and Filter controls. The Quad 44 retains all the beneficial characteristics of its predecessors, the Quad 33 and Quad 22, while incorporating a number of significant and worthwhile improvements in both performance and ergonomics.

test procedure

Complete testing of a 44 may most easily be carried out by using the equipment listed below and inter-connecting these units as illustrated in Fig. 1. Any signal cables used for inter-connecting should be screened.

TEST EQUIPMENT

- Sine/Square A.F. Signal Generator
- A.C. Microvoltmeter
- Oscilloscope
- Anti RIAA Network as shown in Fig. 5

- Mono Amplifier
- Headphones
- 6 x 5 pin Din Plugs

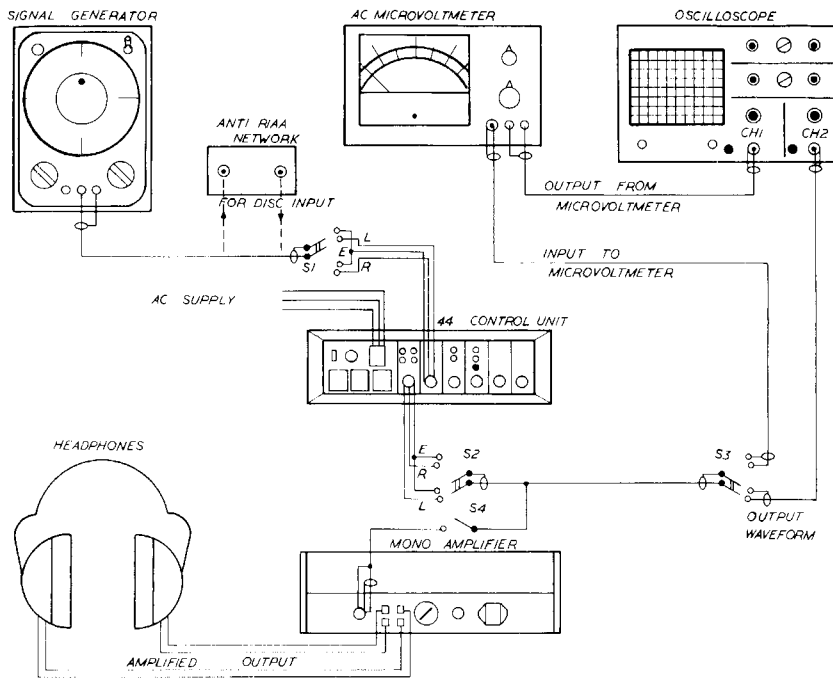

Fig. 1 Suggested Switching Arrangement for Testing

The test equipment should all be connected to a localised common earth point to minimise the effects of earth loop hum.

DIN PLUGS

Four of the DIN plugs should be made up to simulate 100mV loads, to be used in conjunction with noise testing. This is done by connecting two 8K2 Ω resistors as shown in Fig. 2. The other two DIN plugs should be used to link the record pins of each tape module to the replay pins such that the right channel record is connected to the left channel replay and vice versa, as shown in Fig. 3.

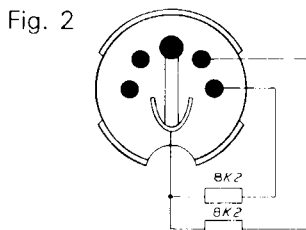

Fig. 2

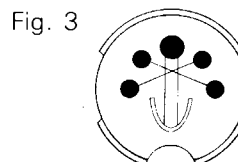

Fig. 3

QUAD 44 service data

CONNECTIONS

S1 to Radio left channel input
0.5V output to S2
S2 to left channel output
S3 to oscilloscope ch2
S4 (Headphones) – off
AC supply to 44

CONTROLS

Signal Generator:
Mode – Square
Frequency – 650Hz
Output level – 100mV Rms

44:
Bass, Tilt, Slope – Zero
Filter Switch – Cancel
Bal-Mon – Bal
Volume – 22
Tape Replay – 0dB
Tape Record – 0dB Low Z
Disc – 3mV

Oscilloscope:
ch1 – 0.5V/cm
ch2 – 0.5V/cm
Timebase – 0.5mS/cm

Microvoltmeter:
Gain – 0dB

1. POWER SUPPLY

When turning the 44 on, the radio and cancel LEDs should illuminate. The AC supply outlet sockets may be checked by plugging a unit into each outlet. The power to the units should then be controlled by the 44 power switch.

2. OUTPUT

Observe the **oscilloscope ch2** beam which should show a square waveform trace as shown in Fig. 4. Switches S1 and S2 should then be adjusted to drive the **right channel input**, and monitor the **right channel output**, when a similar waveform should be displayed. This check should be repeated whilst monitoring the 1.6V and 5V output terminals, and adjusting the **oscilloscope ch2** sensitivity accordingly. Return the switches **S1** and **S2** to the **left channel input** and monitor the **left channel output** using the 0.5V output socket.

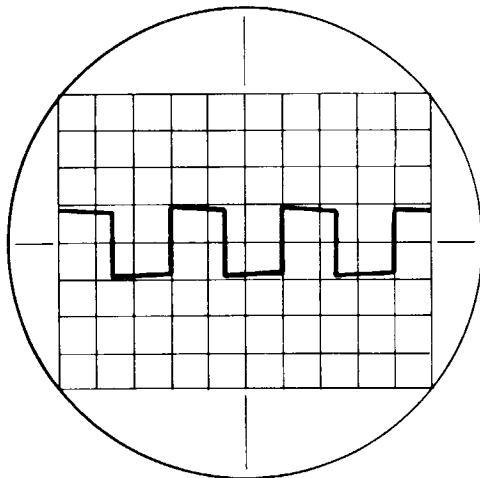

Fig. 4

3. CHANNEL BALANCE

When moving the **balance slider** towards the left, the waveform amplitude should progressively increase to a maximum at the extreme left. When moving the **balance slider** towards the right, the signal amplitude should decrease to zero at the right extreme.

Drive the **right channel input** and monitor the **right channel output** where the opposite to this should be obtained.

Select **mon** on the 44 and move the **balance slider** to the extreme right where the waveform amplitude should reach a maximum of 0.3V. When moving the **balance slider** towards the left the amplitude should progressively reduce to zero.

Drive the **left channel input** and monitor the **left channel output** when the opposite to this should be obtained. Select **Bal** and by switching from channel to channel whilst observing the output waveform produced by each channel, set the **balance** so that the output level from each channel is the same.

4. INPUT SELECTOR AND OUTPUT LEVEL

In the following tests, 'full output' refers to the waveform trace shown in Fig. 4.

RADIO AND TAPE

- (a) Drive the **left channel input** and monitor the **left channel output** to obtain a full output waveform, then monitor the **right channel output** to obtain no output. Drive the **right channel input** and monitor the **right channel output** to obtain a full output waveform, then monitor the **left channel output** to obtain no output.

Insert the **tape link plugs** into the two tape input modules.

- (b) Drive the **left channel input** and monitor the **left channel output** with the **top monitor button** selected, to obtain no output. Monitor the **right channel output** to obtain a full output waveform. Select the **bottom monitor button** and repeat the test. Drive the **right channel input** and monitor the **right channel output** with the **bottom monitor button** selected to obtain no output. Monitor the **left channel output** to obtain a full output waveform. Select the **top monitor button** and repeat the test.

AUXILIARY

Remove the **signal input** lead from the radio input module and adjust the **signal generator** output level to **500mV**. Plug the signal input lead into the auxiliary input module and select **auxiliary**. Repeat test (a) as carried out for radio.

DISC

Remove the **signal input** lead from the auxiliary input. The output from the **signal generator** should be connected to **S2** via the anti RIAA circuit. In order to overcome the 75dB attenuation of the anti RIAA circuit, the input to this circuit should be **16V** which will provide **3mV** to the disc input. It may be found necessary to amplify the signal generator output to achieve these levels. Select **disc** and repeat test (a) as carried out for radio. Where moving coil disc modules are being checked, C1 and C2 should be disconnected and appropriate signal levels should be used.

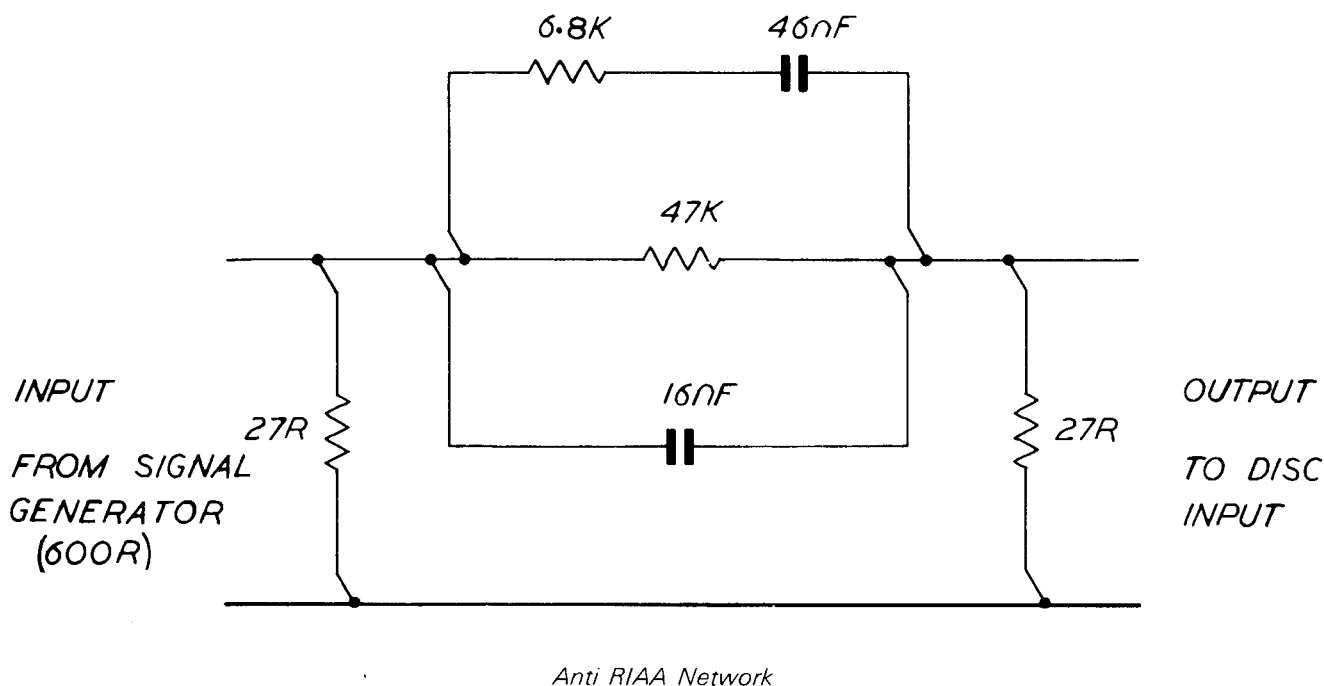

Fig. 5

5. TONE AND FILTERS

Remove the **signal input** lead from the disc input module and adjust the **signal generator** output level to **100mV**. Plug the **signal input** lead into the radio module and select **radio**.

Figs. 6 to 17 show how the output waveform is modified for each of the different tone and filter settings. The checks should be carried out for both channels. Figs. 6 to 17 were drawn using an uncalibrated timebase and sensitivity in order to illustrate more clearly the tone and filter effects.

The cancel position may be checked by selecting **cancel** and any combination of tone settings. There should be no change in the output waveform.

QUAD 44 service data

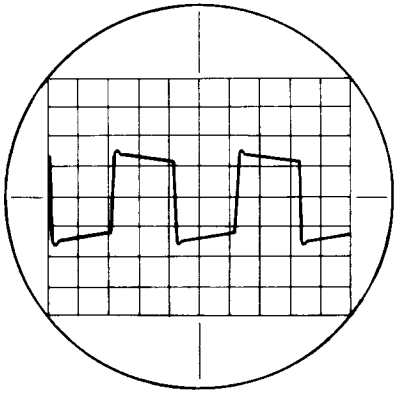

10K Full Slope

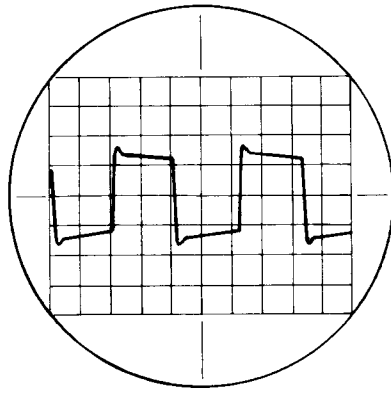

7K Full Slope

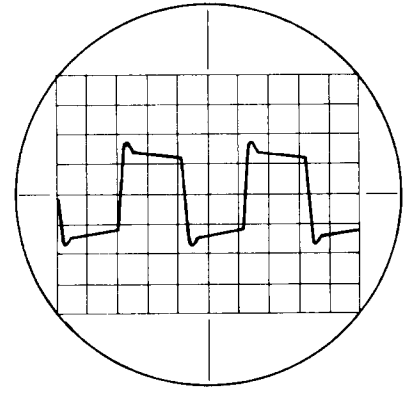

5K Full Slope

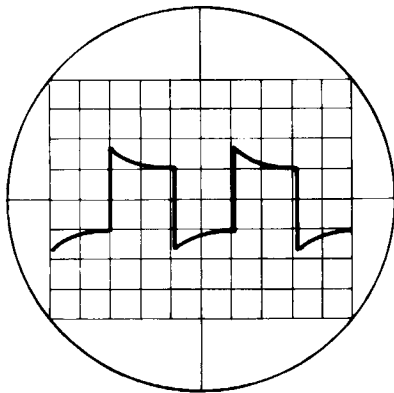

Tilt -1 +1

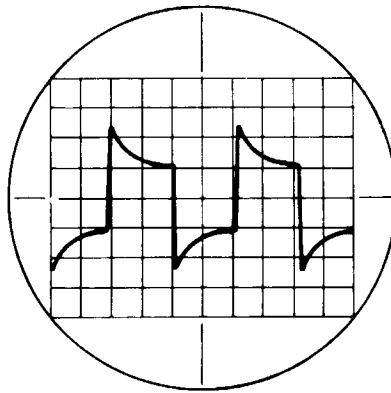

Tilt -2 +2

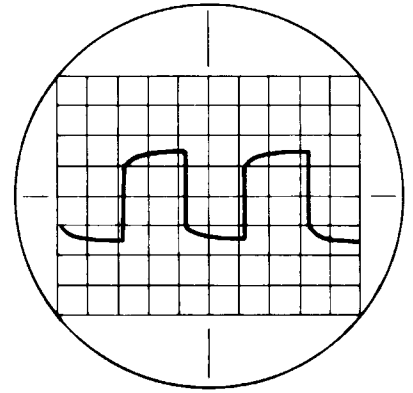

Tilt +1 -1

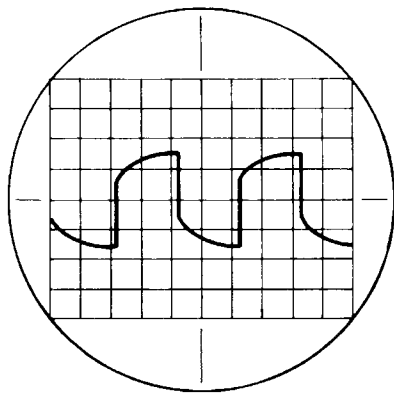

Tilt +2 -2

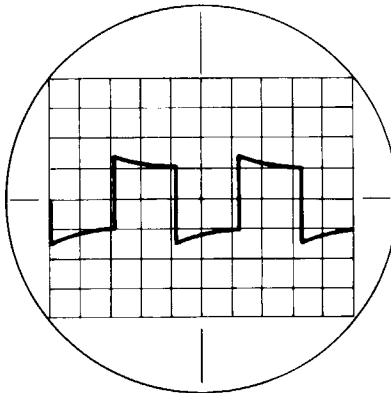

Bass 150 Hz

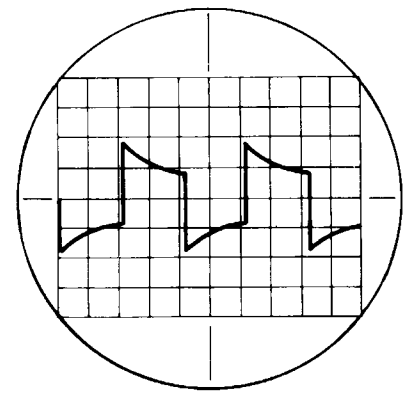

Bass 300 Hz

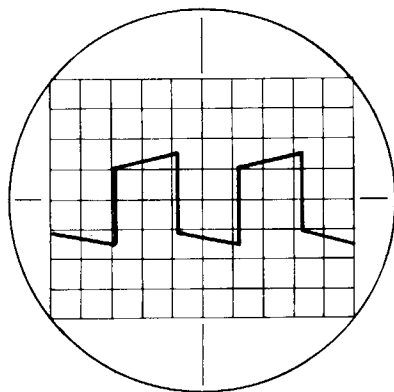

Bass 3dB

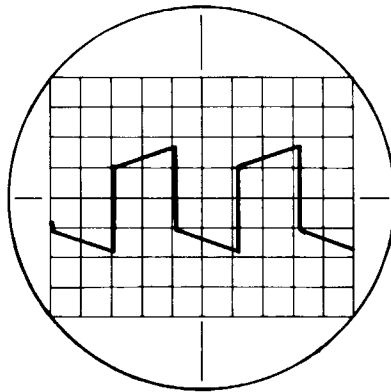

Bass 6dB

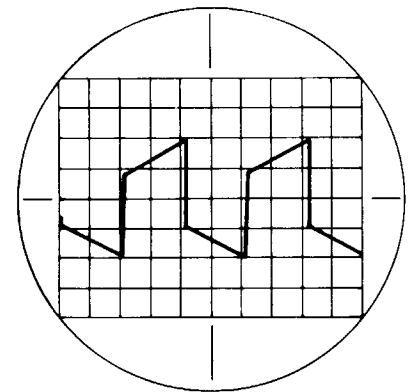

Bass 9dB

6. VOLUME POT

Return all the **tone and filters** to zero. Select a **sinewave** output from the **signal generator** and increase the **frequency** to **10KHz**. Switch **S3** from **oscilloscope** to **A.C. meter input**. Channel **1** of the **oscilloscope** may be used to observe an attenuated output signal if necessary.

Observe the **AC meter** and set the **balance slider** such that the output levels of the **left channel** and **right channel** are equal. Decrease the **volume** one click at a time from **22** down to **1**, checking the attenuation levels for each setting (listed below) and adjusting the **AC meter** as necessary. Repeat the test for the **right channel**.

Numerical Setting	Attenuation in dBs	Numerical Setting	Attenuation in dBs
22	0	11	-22
21	-2	10	-24
20	-4	9	-26
19	-6	8	-28
18	-8	7	-30
17	-10	6	-33
16	-12	5	-37
15	-14	4	-42
14	-16	3	-50
13	-18	2	-60
12	-20	1	-70

7. CROSSTALK

Connect a **1K Ω resistor** between the **right channel** input and earth. Drive the **left channel** input and monitor the output from the **right** channel. Select **-50dB** on the **AC meter** and increase the **volume** setting to **22**. The meter should indicate a nominal crosstalk measurement of better than **-50dB**.

N.B. If test equipment leads are not screened or correctly routed, it may be found difficult to achieve this figure.

The same check should be carried out for driving the **right channel input** and monitoring the output from the **left channel**, with the **left channel input** connected to earth via a **1K Ω resistor**.

8. NOISE

Remove the **1K Ω resistor** and the **signal input** lead. Plug the **100mV load DIN plugs** into the radio and auxiliary input modules.

Adjust both **tape replay** and **record sensitivities** to **100mV** and **low Z** only respectively. The following checks should then be carried out on both channels. Figures quoted in this section are for unweighted noise over a 10Hz to 10KHz bandwidth.

- Select **auxiliary** and the **top monitor button**. The noise reading on the A.C. meter should be better than **-82dB**.
- Repeat (a) with **auxiliary** and the **bottom monitor button** selected.
- Remove the **link plugs** from the tape input modules and replace these with the **100mV DIN plugs**. The noise reading for **radio** and both **tape replay** modules should be better than **-85dB**. For **auxiliary** the reading should be better than **-82dB**.
- Reduce the **volume** to **1** and select **-90dB** on the **AC meter**. The noise reading should be better than **-95dB** for all inputs.
- Adjust the **AC meter** to **-50dB** and increase the **volume** to **22**. Select **disc** and the noise reading should be better than **57dB** for **1mV** setting, **67dB** for **3mV** setting and **76dB** for **10mV** setting.
- Adjust the **microvoltmeter** to **0dB** and switch **S4**, the headphones, on. With **disc** selected randomly switch all **tone** and **filter** buttons whilst listening for any clicks which may be caused by noisy switches. Switch **all inputs** randomly listening again for noisy switches on the input selector board. Remove the **disc source**.

9. RELAY CIRCUIT

The relay circuit may be checked by turning the **44** off, then turning on again whilst holding the **disc input** button in. After between 2 and 4 seconds noise should be heard through the headphones. This check should be carried out on both channels.

fault finding

The numbers in the following section correspond to the appropriate test check.

	Symptom	Probable Cause
1. Power	Selector and cancel LEDs do not illuminate, also there is no power output to other units.	Fault lies inside the AC supply box.
	Selector and cancel LEDs do not illuminate but there is power output to other units.	Check Fuse. Check for positive and negative HT volts. If there are no negative HT volts suspect: TR403 TIP31 O/C R405 10 Ω O/C
	44 will not switch off.	Faulty A.C. switch
2. Output	No output on either channel for any selected input.	Relay circuit faulty. Short circuit across output plate. Insecure Amp connectors.
	No output on one channel only for any selected input.	Open circuit connection on output plate. Short circuit across output plate. Faulty Relay. IC500 – IC503 U/S. Open circuit connection on the volume pot. Open circuit connection on the balance pot. Output phono socket loose.
3. Balance Slider	When moving the balance slider the output becomes intermittent.	Broken balance slider tag. Break in resistance track.
4. Input Selector and Output Level	No or low output when selecting a particular input.	Input module faulty, the integrated circuit is the most likely cause. Other causes: DIL switches O/C (where applicable). Transistors (where applicable).
	Output waveform hums on a particular input.	Input module board to rear panel earth broken.
	44 randomly selects any input source, or reverts to the radio input.	IC400 – IC403 leaking. Selector switches intermittently short circuit. If the fault occurs very infrequently it may be cured by soldering a 0.1 μ F capacitor across the HT volt supply rails on the button board M12428.
	44 will only select 1 input source despite switching for others.	IC100 – IC102
5. Tone and Filters	Cancel LED not working.	Cancel LED open circuit.
	Slope pot working intermittently.	Intermittent open circuit on slope pot.

6. Volume Pot

Output becomes intermittent when volume knob is adjusted.

Intermittent open circuit joint between volume pot and tone board.

7. Crosstalk

Excessive crosstalk.

Open circuit earth connection particularly the screws securing the mother board which should be tight.

8. Noise

Noise figures excessive for all inputs with volume at 22.

IC500, IC501.

Noise figures excessive for all inputs with volume at 1.

IC502, IC503

Noise figures excessive for a particular input.

Input module faulty. Suspect integrated circuit or any associated transistors.

Switch clicks.

Switch contacts dirty. Use suitable switch cleaning lubricant.

This may be particularly applicable to volume pots and relays.

9. Relay Circuit

Relay Chatter

Low HT volts.

Speakers thump when 44 is turned off, on 44's where the relay is fitted to the tone board.

Relay switch off time too slow. Connect a $4.7\mu\text{F}$ capacitor from +15V to the base of TR501.

block diagram

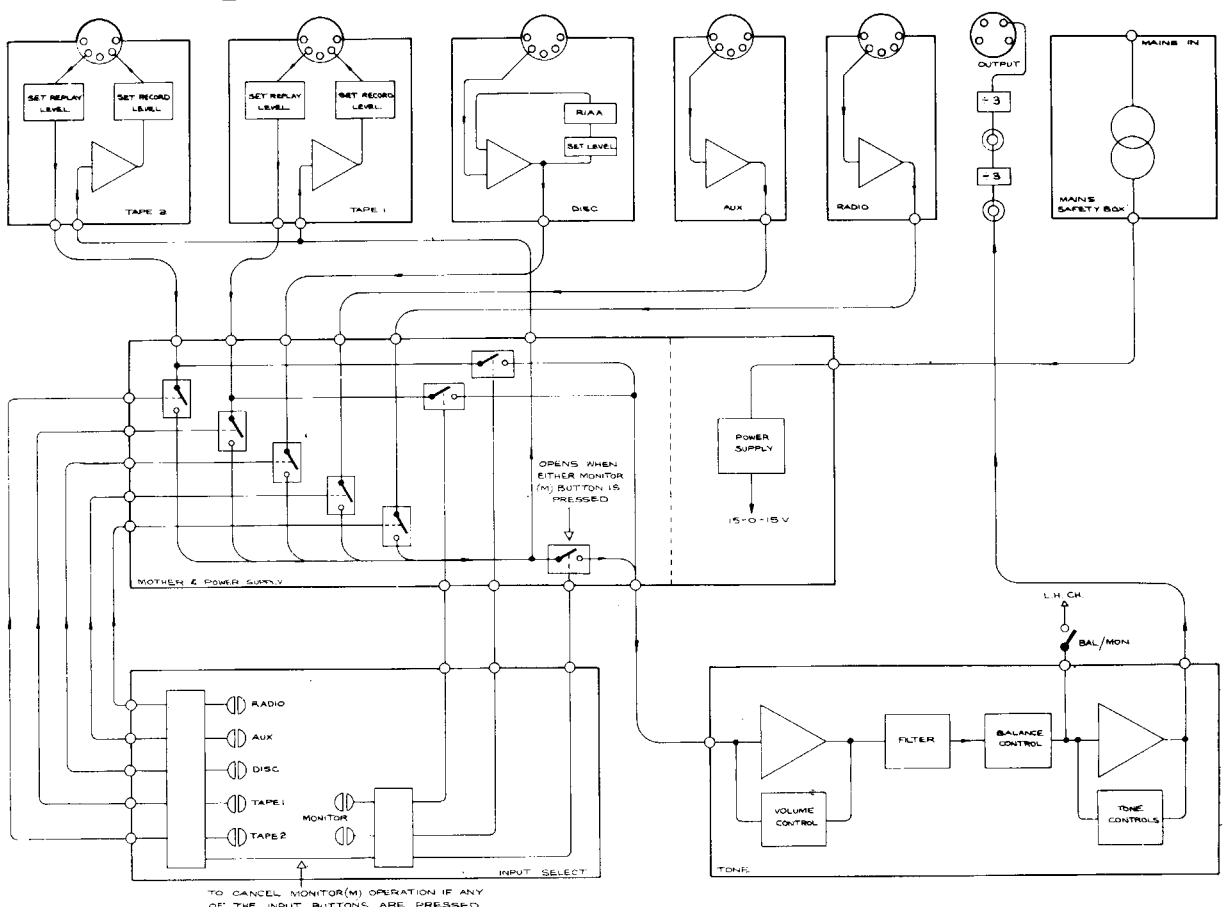

QUAD 44 service data

input selector

M12428 - ISS 5

Qty	Ref. No.	Stock No.	Description
7	R100, R102, R104, R106, R108, R113, R115	R10K0J1	Resistor 10K ±5%
8	R101, R103, R105, R107, R109, R112, R114, R117	R750RJ1	Resistor 750 ±5%
3	R110, R111, R116	R1M00J1	Resistor 1M ±5%
5	C100-C104	C4N705J	Capacitor 4n7
3	C105-C107	C4N705E	Capacitor 4n7
5	D100-D104	BL556G2	LED green
2	D105-D106	BL5053R	LED red
7	S100-S106	S44INPA	Switch D6
1	IC100	D16862A	Integrated circuit SN16862
2	IC101 IC102	D16861N	Integrated circuit SN16861
1		I12428A	Printed wiring board DRG M1242H

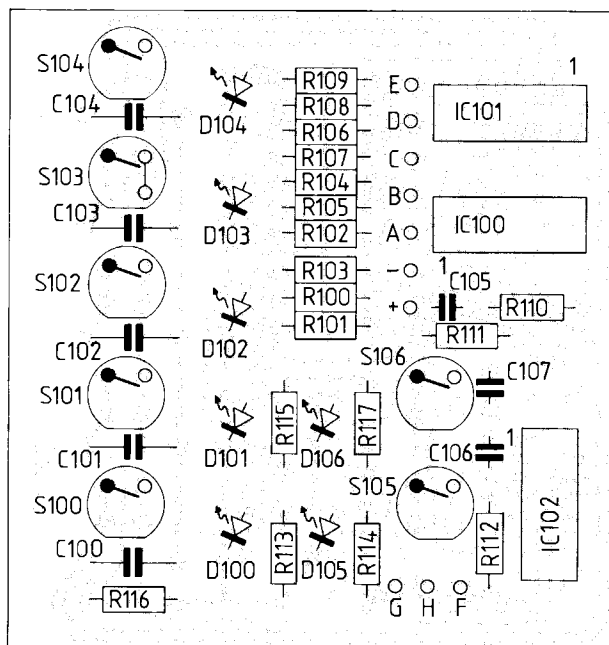
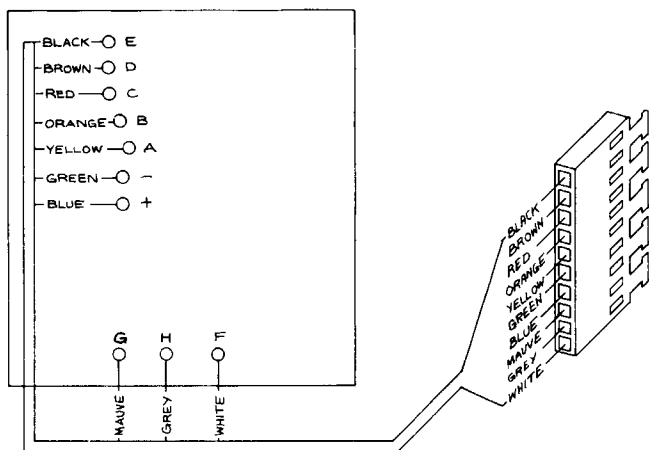

DC OUTPUT VOLTAGES TO OPERATE ELECTRONIC SWITCHES ON MOTHER BOARD

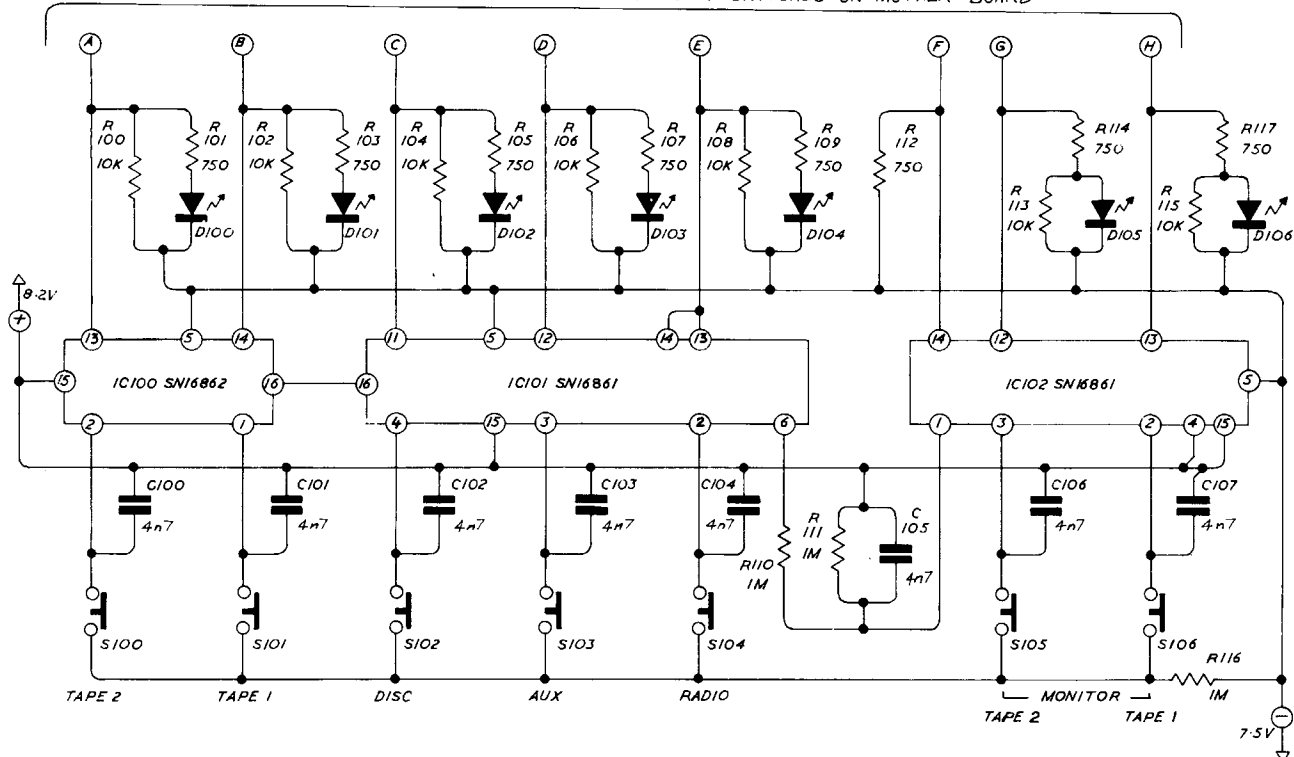

modifications

Original Issue board M12428 Issue 4.

M12428 Issue 5

For production purposes, LED's no longer soldered to the board, but housed in gold connector sockets.

INPUT SELECTOR BOARD

Part No.	Description	Circuit Reference
BL5053R	LED XC5053R Red	D105, D106
BL556G2	LED XC556G-2 Green	D100 to D104
C4N70ZM	Capacitor 4.7n 629-06472	C105, C106, C107
S44INPA	Input Select Switch	S100 to S106
C4N70SJ	Capacitor 4.7n UP125 U 472 KB	C100 to C104
D16861N	Int Cct SN16861NG	IC101, IC102
D16862A	Int Cct SN16862AN	IC100
I12428A	PCB Input Selector M12428.5	
R10K0J1	Resistor 10K 5 050	R100, R102, R104, R106, R108, R113, R115
R1M00J1	Resistor 1M 5 050	R110, R111, R116
R750R1	Resistor 750 5 050	R101, R103, R105, R107, R109, R112, R114, R117
PAM8634	Gold Board Socket	

mother board and power supply

M12436 - ISS 4

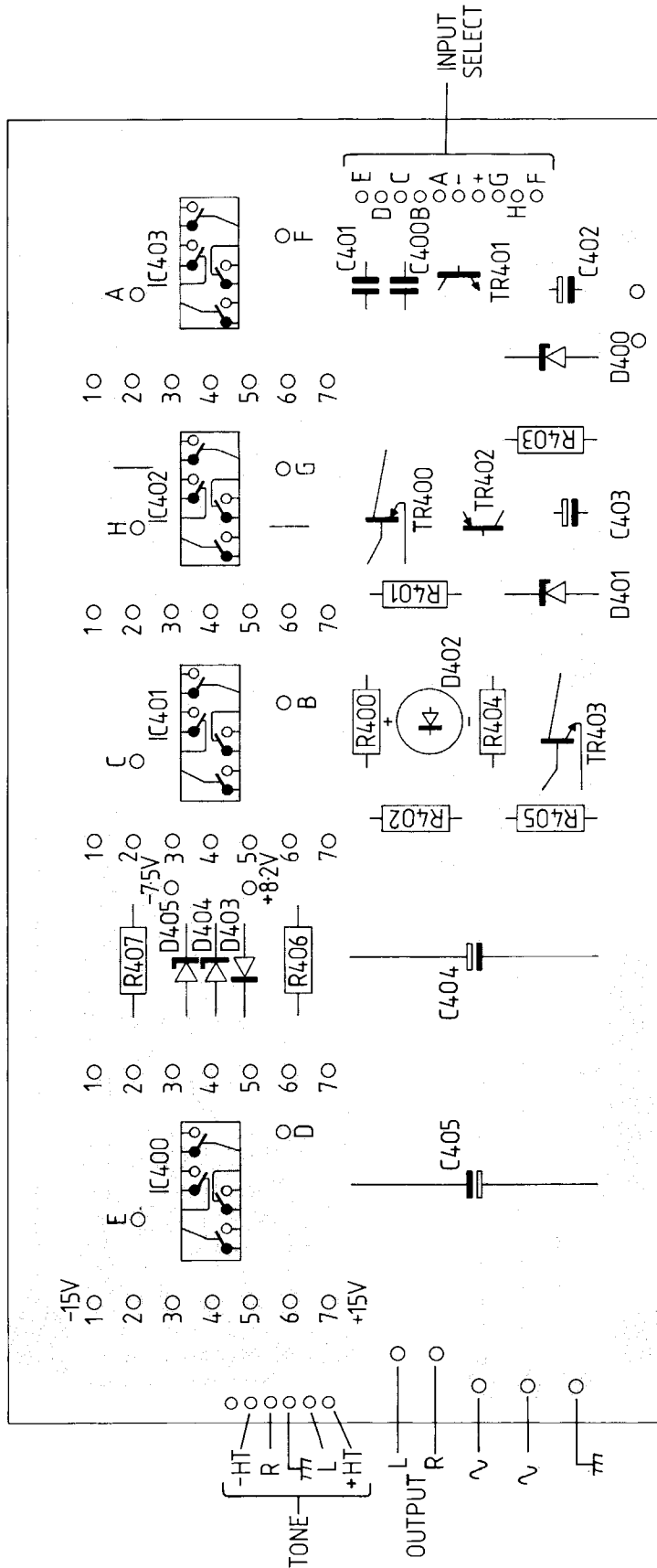

mother board and power supply

M12436 – ISS 4

Qty	Ref. No.	Stock No.	Description
4	IC400, IC401, IC402, IC403	D4066AA	Integrated circuit CD4066BE
1	TR400	DTIP32X	Transistor BD242
1	TR401	DBC441X	Transistor BC441
1	TR402	DBC461X	Transistor BC461
1	TR403	DTIP31X	Transistor BD441
2	D400, D401	DZ15VAA	Zener diode BZY88C 15V
2	D404, D405	DZ7V5AA	Zener diode BZY88C 7.5V
1	D403	DIS920B	Diode IS920
1	D402	DW02XXX	Rectifier W02
4	R401, R402, R403, R404	R3K30J1	Resistor 3k3 ±5%
2	R400, R405	R10R0J1	Resistor 10 ±5%
2	R406, R407	R120RJA	Resistor 120 ±5%
2	C400, C401	CU047ZL	Capacitor 47 n
2	C402, C403	C47U0ZE	Capacitor 47µ 16V
2	C404, C405	C1K0UTM	Capacitor 1000µ 25V
1			Printed board to DRG M12436

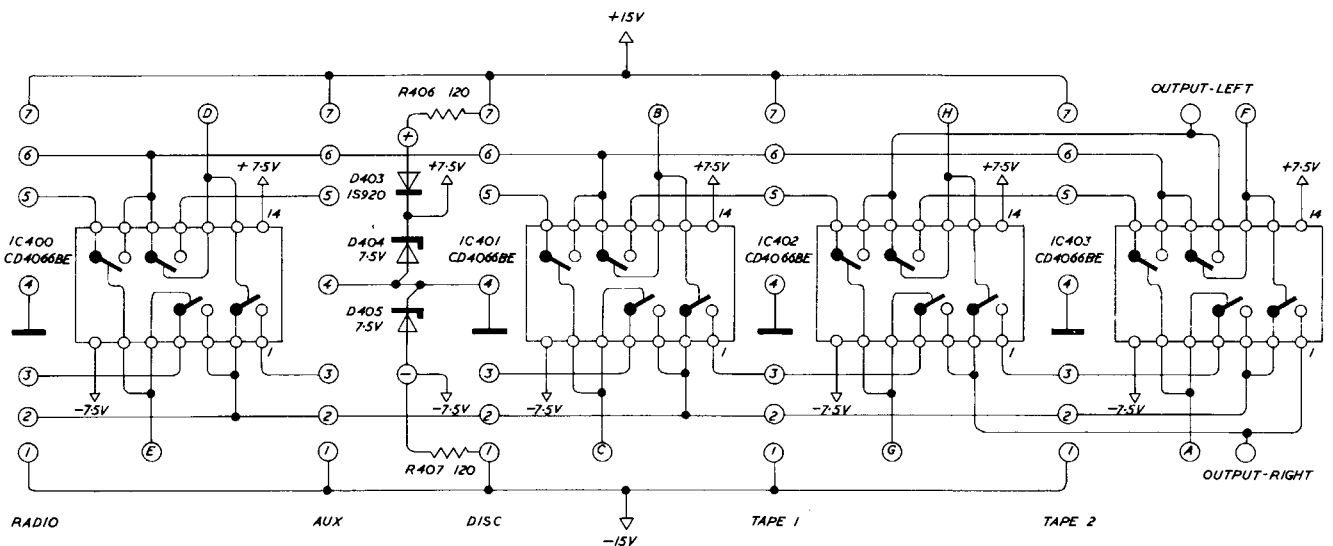
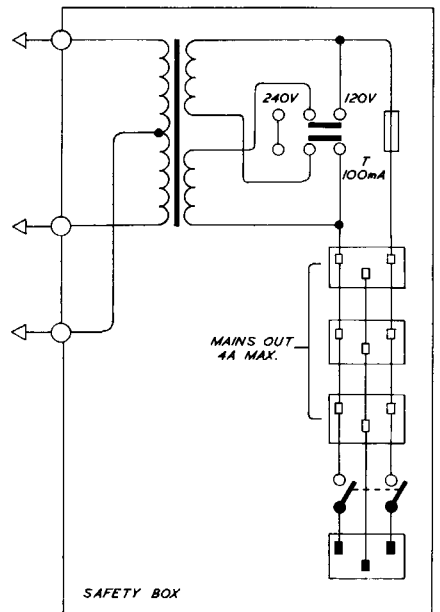
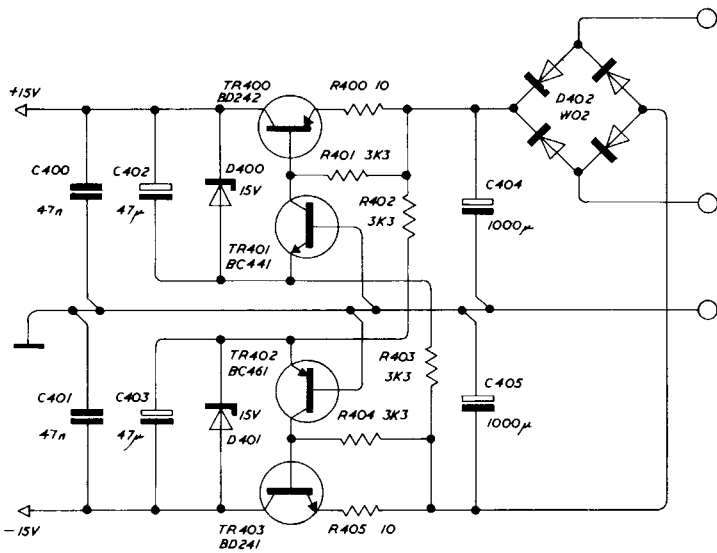

mother board and power supply

M12436 - ISS 5

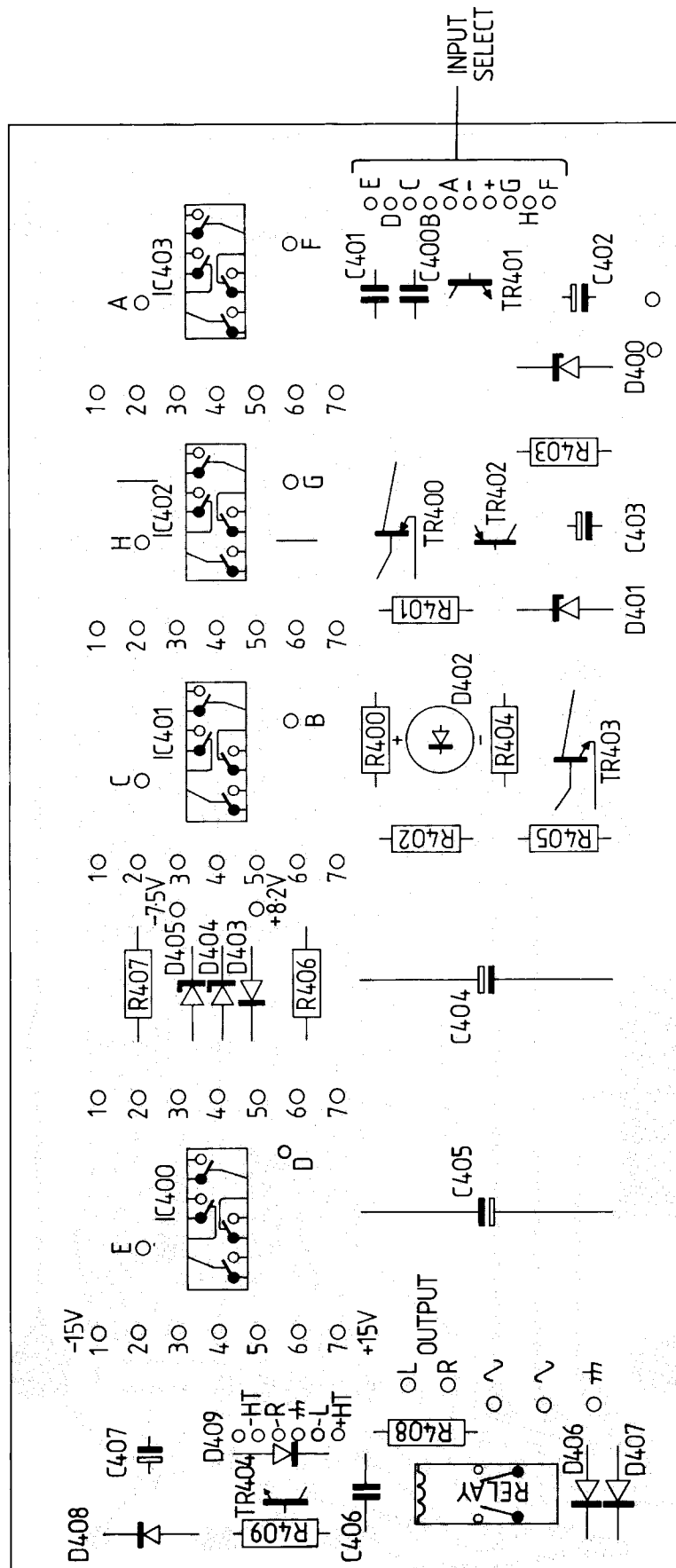

mother board and power supply

M12436 - ISS 5

Qty	Ref. No.	Stock No.	Description
4	IC400, IC401, IC402, IC403	D4066AA	Integrated Circuit CD4066BE
1	TR404	DBC413X	Transistor BC413C
1	TR400	DTIP32X	Transistor TIP32
1	TR401	DBC441X	Transistor BC441
1	TR402	DBC461X	Transistor BC461
1	TR403	DTIP31X	Transistor TIP31
2	D400, D401	DZ15VAA	Zener Diode BZY88C 15V
2	D404, D405	DZ7V5AA	Zener Diode BZY88C 7.5V
5	D403, D406, D407, D408, D409	DIS920B	Diode IS920
1	D402	DW02XXX	Rectifier W02
4	R401, R402, R403, R404	R3K30J1	Resistor 3K3 ±5%
2	R400, R405	R10R0J1	Resistor 10 ±5%
2	R406, R407	R120RJA	Resistor 120 ±5%
1	R408	R220RJ1	Resistor 220 ±5%
1	R409	R4K70J1	Resistor 4K7 ±5%
2	C400, C401	C100NKA	Capacitor 100n
2	C402, C403	C47U0ZE	Capacitor 47µ 40V
2	C404, C405	C1K0UTM	Capacitor 1000µ 25V
1	C406	C68N0KS	Capacitor 68n
1	C407	C100UZE	Capacitor 100µ
1		I12436A	Printed Board to DRG M12436
1		SMG2V2A	Relay G2V2 12V
1	S400	NPMR20A	Suppressor PMR 209M
1	F400	UMA10DA	Fuse T100mA
1	T400	L12527A	Mains Transformer

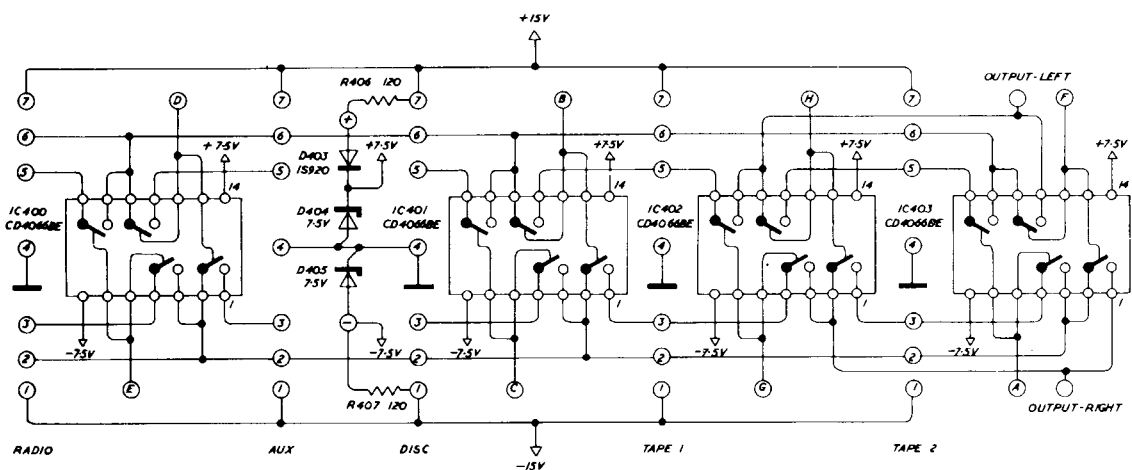
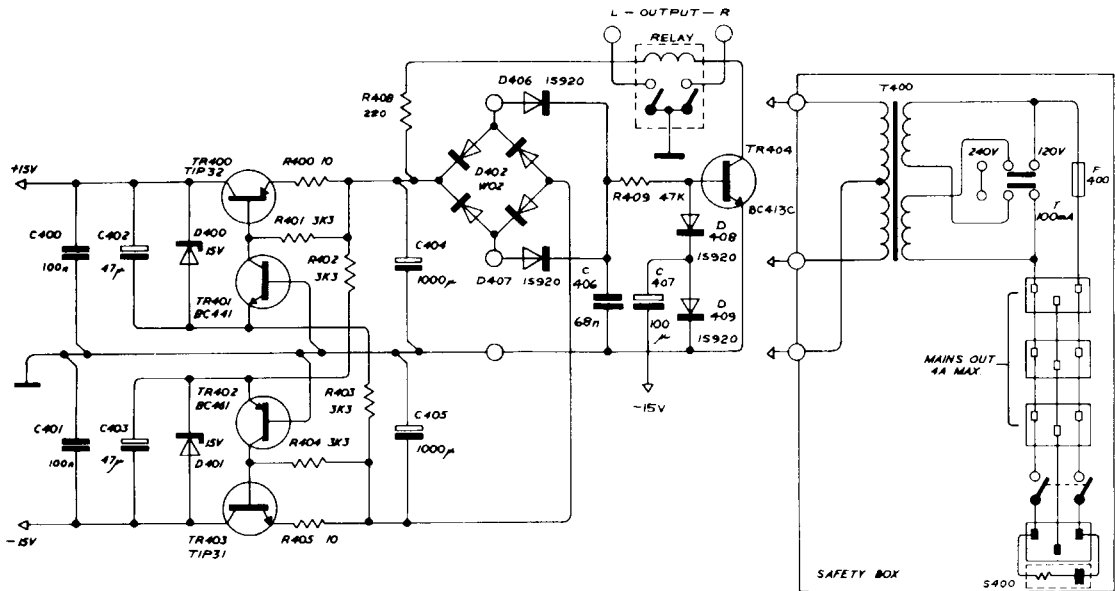

modifications

ORIGINAL ISSUE BOARD M12436 ISS 3

M12436 ISSUE 4

The printed copper loop surrounding the board identification number has been turned into a large copper pad. This is to minimise the effects of earth loop hum.

The Green 3 way pin cluster has been removed and the holes enlarged to accommodate two spade type tags.

M12436 ISSUE 5 SERIAL NUMBER 12000

The board now incorporates a modified version of the relay circuit which had previously been fitted to the tone control board, M12512 ISS 8.

The two types of relay are not interchangeable.

The board is also fitted with modified connectors. C400, C401 change from 47n to 100n.

If a pre-serial number 12000 44 is to be fitted with an Issue 5 mother board the following instructions should be followed.

1. Remove and discard the relay HB2 24V and transistors TR500 and 501 from the tone control board, M12512 Issue 8 or earlier.
2. Remove and discard the 2-way and 5-way connections between the tone control board and the mother board. Replace with new connectors soldered to the tone control board, using the same colour coding. The new connectors complete with wiring may be ordered as Quad reference:
2-way Q44CON2
5-way Q44CON5

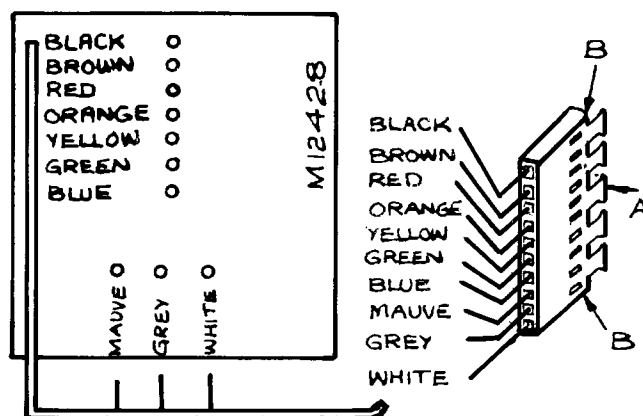

Fig. 18

3. Modify the existing 10-way connector by cutting off the five teeth marked A. Remove the sharp corners at B, to enable the connector to fit snugly into the mother board connector, with the white wire nearest the bottom of the 44.

When re-connecting the signal leads, maintain the channel identification, red is right and white is left. In the connection between the output socket and the mother board, the white wire should now occupy the eyelet closest to the 5-way connector.

COMPONENT ALTERNATIVES:

TR400	TIP32, BD242
TR401	BC441, BC440-6
TR402	BC461, BC460-6
TR403	TIP31, BD241
TR404	E5270, BC413C

MOTHER BOARD

Part No.	Description	Circuit Reference
C100NKS	Capacitor 100nF 10 100V B32510	C400, C401
C100UZB	Capacitor 100 μ F 16V EK	C407
C1KOUTA	Capacitor 1000 μ 25V -10+50	C404, C405
C47UOZB	Capacitor 47 μ 40V EK	C402, C403
C68NOKS	Capacitor 68nF 10 400V B32561	C406
DBC4406	Transistor BC440-6	TR401
DBC4606	Transistor BC460-6	TR402
DE5270X	Transistor E5270	TR404
DTIP31X	Transistor TIP31	TR403
DTIP32X	Transistor TIP32	TR400
DW02XXX	Bridge Rectifier W02	D402
IWT05XX	Transistor Pad T05-009D	
PAM1872	Male Tags	
PAM3702	Black Pin Cluster – 2 way	
PAM3722	Black Pin Cluster – 6 way	
PAM3742	Black Pin Cluster – 10 way	
PAM4330	Green Pin Cluster – 10 way	
PAM4333	Green Pin Cluster – 3 way	
PAM4335	Green Pin Cluster – 5 way	
SMG2V2A	Relay G2V2 12V DC	
TM306PA	Screw M3 6mm Sup. Pan. St. Bzp	Do not use on Q44 earlier than serial number 12000
TM3FHFA	Nut M3 Full Hex St. Bzp	
D4066AA	Int. Cct. CD4066BCN	IC400, IC401, IC402, IC403
DIS920B	Diode IS920TB	D403, D406, D407, D408, D409
DZ15VAA	Zener Diode BZY88C15V	D400, D401
DZ7V5AA	Zener Diode BZY88C7V5	D404, D405
I12436A	PCB Mother Board M12436 ISS 5	
PAM0358	Black Self-retaining Skt 2 way	
PAM0360	Black Self-retaining Skt 6 way	
PAM0362	Black Self-retaining Skt 10 way	
PAM3693	Green Self-retaining Skt 3 way	
PAM3695	Green Self-retaining Skt 5 way	
PAM3690	Green Self-retaining Skt 10 way	
PAM9341	Gold PINS	
R10R0K1	Resistor 10 10 050	R400, R405
R120RJA	Resistor 120 5 075	R406, R407
R220RJ1	Resistor 220 5 050	R408
R3K30J1	Resistor 3K3 5 050	R401, R402, R403, R404
R4K70J1	Resistor 4K7 5 050	R409

QUAD 44 service data

disc input

M12515 - ISS 4

Qty	Ref. No.	Stock No.	Description
2	IC300, IC301	D5534AX	Integrated circuit TDA1034NB
2	R300, R301	R4K70J1	Resistor 4K7 $\pm 5\%$
2	R302, R303	R47K0J1	Resistor 47K $\pm 5\%$
2	R304, R305	R390RG1	Resistor 390 $\pm 2\%$
2	R306, R307	R150KG1	Resistor 150K $\pm 2\%$
2	R308, R309	R9K10G1	Resistor 9K1 $\pm 2\%$
2	R310, R311	R10K0J1	Resistor 10K $\pm 5\%$
4	R312, R313, R1K00J1		Resistor 1K $\pm 2\%$
	R318, R319		
2	R314, R315	R330RG1	Resistor 330 $\pm 2\%$
2	R316, R317	R150RG1	Resistor 150 $\pm 2\%$
2	R320, R321	R1K20G1	Resistor 1K2 $\pm 2\%$
2	R322, R323	R6K80G1	Resistor 6K8 $\pm 2\%$
2	C300, C301	C180PHL	Capacitor 180p
2	C304, C305	C10U0KT	Capacitor 10 μ 16V
2	C306, C307	CU033JS	Capacitor 33n
2	C308, C309	CU150JS	Capacitor 15 μ $\pm 5\%$
2	C310, C311	C2U20KT	Capacitor 2.2 μ 16V
4	C312, C313, C47POKJ		Capacitor 47p
	C302, C303		
2	C314, C315	CU047ZL	Capacitor 47n
1	SK300	PS05DNB	5 pin DIN socket
4	L300, L301, L302, L303	LSC1001	Choke 1mH
1	S300-S303	S44DILA	DIL switch DYS-4DS
5	1.3.4.5.7.	PAM8634	Board socket
1		I12515A	Printed board to DRG M12515

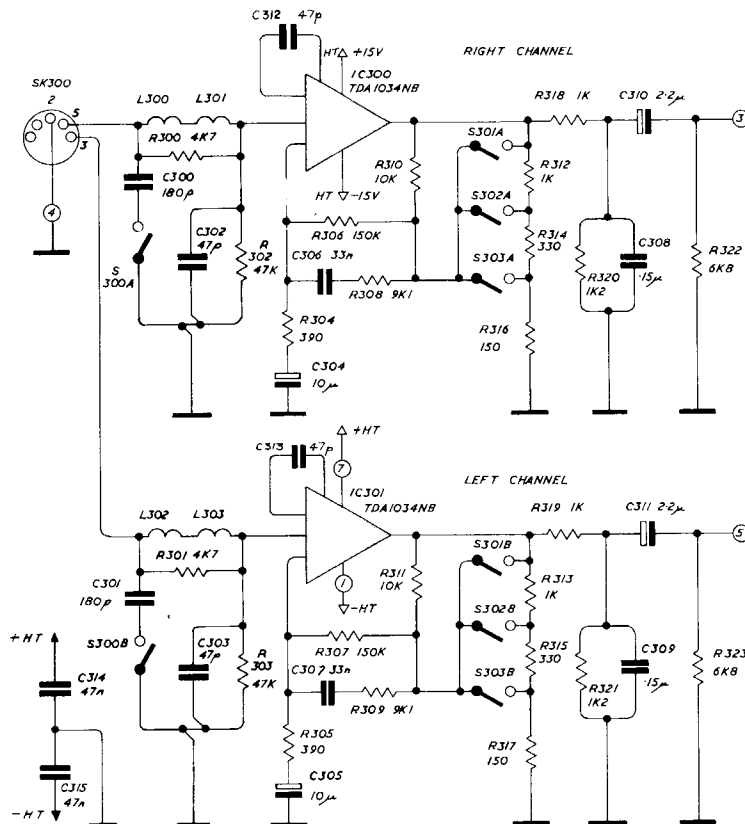
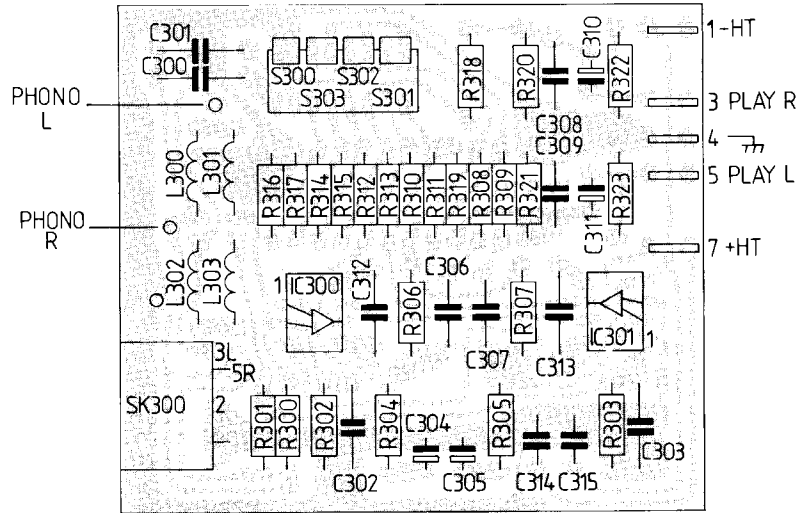

disc input

M12515 - ISS 5

Qty	Ref. No.	Stock No.	Description
8	R300, R301, R302, R303, R304, R305, R306, R307	R47K0J1	Resistor 47K $\pm 5\%$
2	R308, R309	R750RG1	Resistor 750 $\pm 2\%$
2	R310, R312	R4K70J1	Resistor 4K7 $\pm 5\%$
2	R311, R313	R100KG1	Resistor 100K $\pm 2\%$
2	R314, R315	R180KJ1	Resistor 180K $\pm 5\%$
2	R316, R317	R470KG1	Resistor 470K $\pm 2\%$
6	R314, R315, R318, R319, R328, R329	R10KOG1	Resistor 10K $\pm 2\%$
4	R320, R322, R326, R327	R1K10G1	Resistor 1K1 $\pm 2\%$
2	R321, R323	R330RG1	Resistor 330 $\pm 2\%$
2	R324, R332	R150RG1	Resistor 150 $\pm 2\%$
2	R330, R331	R3K00G1	Resistor 3K $\pm 2\%$
2	C300, C301	C180PKE	Capacitor 180p $\pm 10\%$
2	C302, C303	C47U0MU	Capacitor 47 μ $\pm 20\%$ 6V3
4	C304, C305, C306, C307	C1U50KT	Capacitor 1 μ 5 $\pm 10\%$
2	C308, C309	C33N0JS	Capacitor 33n $\pm 5\%$
4	C310, C311, C316, C317	C2U20KU	Capacitor 2 μ 2 $\pm 10\%$
2	C314, C315	C100NJS	Capacitor .1 μ $\pm 5\%$
2	C312, C313	C6N80KS	Capacitor 6n8 $\pm 10\%$
2	IC300, IC301	D071CPX	Integrated circuit TL071
2	TR300, TR302	DBC214C	Transistor BC214C
2	TR301, TR303	DBC413X	Transistor BC413C
1	S300-S303	S44DILA	DIL switch
1	SK300	PS05DNB	5-pin DIN skt.
5	1,3,4,5,7	PAM8634	Board skts.
1		I12515B	Printed wiring board M12515

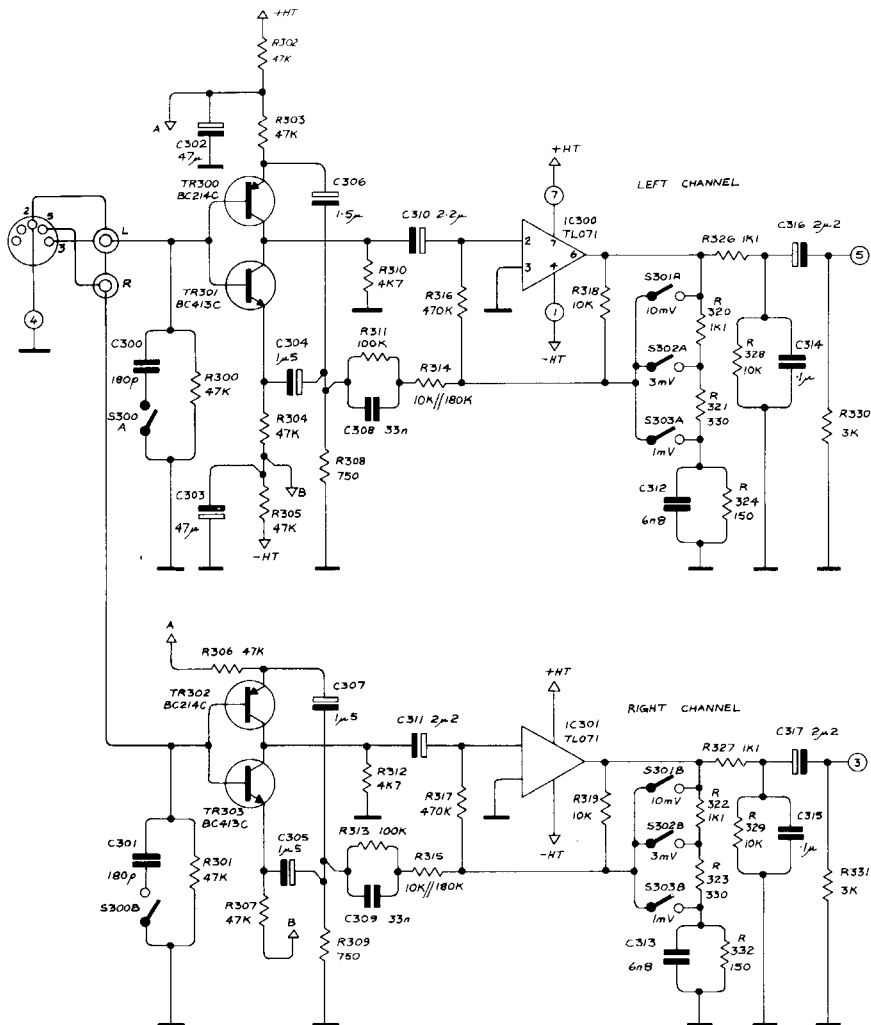
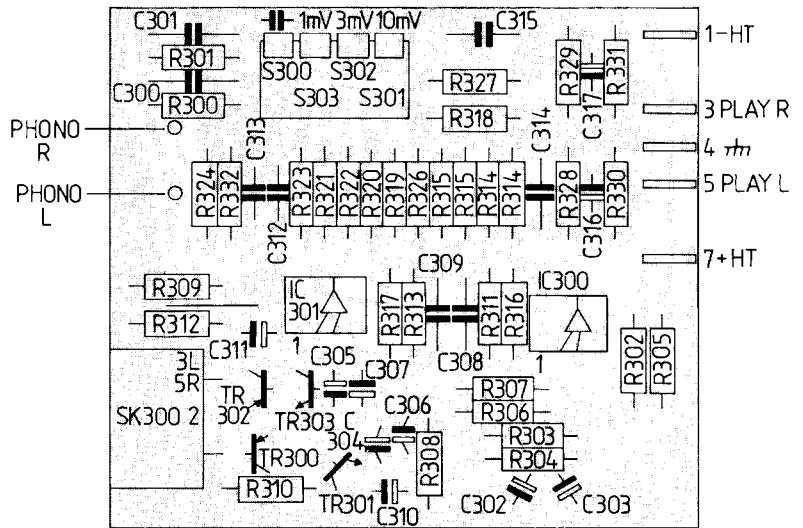

modifications

ORIGINAL ISSUE BOARD M12515 ISS 4

Equalisation is to IEC for which: t1 = 75 μ s
 t2 = 318 μ s
 t3 = 3180 μ s
 t4 = 7950 μ s

COMPONENT EQUIVALENTS

1C300 1C301 – TDA1034, NE5534.

M12515 ISS 5 SERIAL NUMBER 12000

The circuit has been completely re-designed for manufacturing purposes. This module should only be used on 44's fitted with mother board type M12436 ISS 5. Use with mother boards M12436 ISS 3 and 4 may result in severe switch off thumps.

Equalisation is to RIAA for which: t1 = 75 μ s
 t2 = 318 μ s
 t3 = 3180 μ s

DISC MODULE M12515 ISS 4

Part No.	Description	Circuit Reference
C180PHL	Capacitor 180p	C300, C301
C10U0KT	Capacitor 10 μ 16V	C304, C305
CU033JS	Capacitor 33n	C306, C307
CU150JS	Capacitor .15 μ \pm 5%	C308, C309
C2U20KT	Capacitor 2.2 μ 16V	C310, C311
C47P0KJ	Capacitor 47p	C312, C313, C302, C303
CU047ZL	Capacitor 47n	C314, C315
R4K70J1	Resistor 4K7 5%	R300, R301
R47K0J1	Resistor 47K 5%	R302, R303
R390RG1	Resistor 390 2%	R304, R305
R150KG1	Resistor 150K 2%	R306, R307
R9K10G1	Resistor 9K1 2%	R308, R309
R10K0J1	Resistor 10K 5%	R310, R311
R1K00J1	Resistor 1K 2%	R312, R313, R318, R319
R330RG1	Resistor 330 2%	R314, R315
R150RG1	Resistor 150 2%	R316, R317
R1K20G1	Resistor 1K2 2%	R320, R321
R6K80G1	Resistor 6K8 2%	R322, R323
D5534AX	Integrated Circuit NE5534AN	IC300, IC301
PS05DNB	5 Pin DIN socket	SK300
LSC1001	Choke 1mH	L300, L301, L302, L303
S44DILA	DIL Switch DYS-4DS	S300 – S303
PAM8634	Gold Board Socket	1, 3, 4, 5, 7
I12515A	PCB Disc 12515 ISS 4	
M12443A	Disc Input Plate	
PQ1124A	Terminal Screw + Earth Symbol	
PSPHON2	Socket Phono Red AT700NP	
PSPHON9	Socket Phono White AT700NP	
TC205PF	Drive Screw 3/16 2Z Sup Black	

DISC MODULE M12515 ISS 5

Part No.	Description	Circuit Reference
C100NJS	Capacitor 100nF 5 250V B32561	C314, C315
C1U50KT	Capacitor 1.5 μ 10 Tant	C304, C305, C306, C307
C2U20KT	Capacitor 2.2 μ 10 16V Tant	C310, C311
C2U20TM	Capacitor 2.2 μ 25V	C316, C317
C33NOJS	Capacitor 33nF 5 250V B32561	C308, C309
C47U0MT	Capacitor 47 μ 20 6.3V Tant	C302, C303
C6N80KS	Capacitor 6.8nF 10 400V B32560	C312, C313
DBC214C	Transistor BC214C	TR300, TR302
DE5270X	Transistor E5270	TR301, TR303
C180PKJ	Capacitor 180p UP125 B181KB	C300, C301
D071CPX	Int Cct TL071CP	IC300, IC301
I12515B	PCB Disc 12515 ISS 5	
M12443A	Disc Input Plate	
PAM8634	Gold Board Socket	1, 3, 4, 5, 7
PQ1124A	Terminal Screw + Earth Symbol	
PS05DNB	Socket 5 pin DIN Angle Panel	
PSPHON2	Socket Phono Red AT700NP	
PSPHON9	Socket Phono White AT700NP	
R100KG1	Resistor 100K 2 050	R311, R313
R10K0G1	Resistor 10K 2 050	R314, R315, R318, R319, R328, R329
R150RG1	Resistor 150 2 050	R324, R332
R180KJ1	Resistor 180K 5 050	R314, R315
R1K10G1	Resistor 1K1 2 050	R320, R322, R326, R327
R330RG1	Resistor 330 2 050	R321, R323
R3K00G0	Resistor 3K 2 033	R330, R331
R470KG1	Resistor 470K 2 050	R316, R317
R47K0J1	Resistor 47K 5 050	R300 to R307 inc.
R4K70J1	Resistor 4K7 5 050	R310, R312
R750RG1	Resistor 750 2 050	R308, R309
S44DILA	Switch 44 DIL DYS-4DS	S300 to 303 inc.
TC205PF	Drive Screw 3/16 2Z Sup Black	

moving coil disc input

M12542 - ISS 3

Type	Sensi- tivity	Impedance Capacity	Modification
A	300μ V	470Ω 22n	As circuit diagram
B	100μ V	100Ω 68n	R1, R2 = 100n, R13, R14 = 6Ω, R17, R18 = 100K R21, R22 = 1M, C1, C2 = 68n, C5, C6, C7, C8 = 68μ
C	300μ V	100Ω 68n	R1, R2 = 100Ω, C1, C2 = 68n
D	100μ V	470Ω 22n	R13, R14 = 6Ω, R17, R18 = 100K, R21, R22 = 1M, C5, C6, C7, C8 = 68μ
E	100μ V	100Ω 1μ5	R1, R2 = 100Ω, R13, R14 = 6Ω, R17, R18 = 100K, R21, R22 = 1M, C1, C2 = 1.5μ, C5, C6, C7, C8 = 68μ
F	300μ V	100Ω 1.5μ	R1, R2 = 100Ω, C1, C2 = 1.5μ

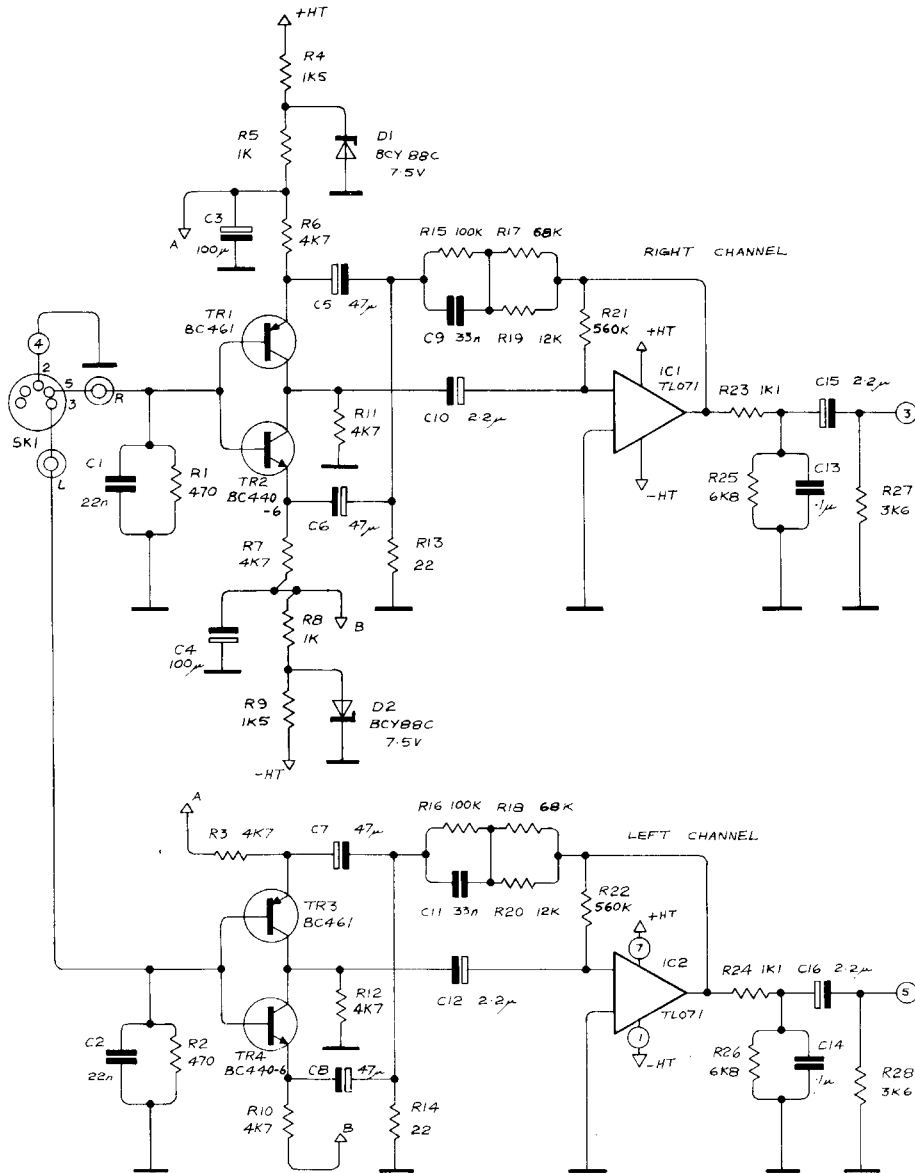
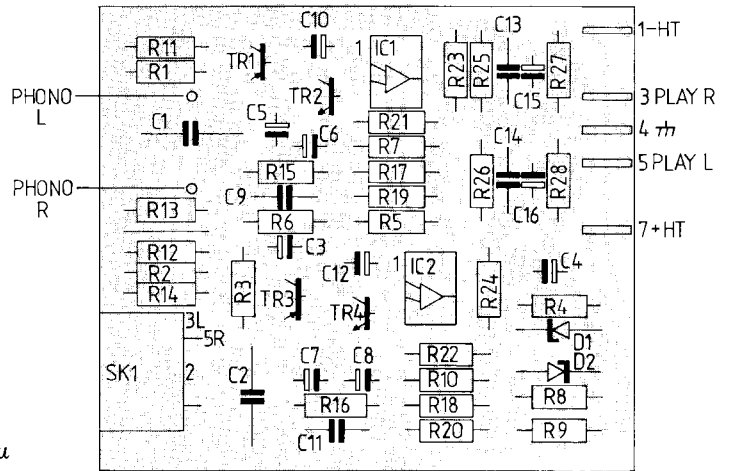

modifications

ORIGINAL ISSUE BOARD – M12542 ISS 3

On moving coil module types A, C and F, R17 changes from 68K to 91K. The circuit shown is with equalisation to RIAA. For equalisation to IEC values of R15, R17 and R21 change as follows:

	Types A, C and F	Types B, D and E
R15	100K	91K
R17	82K	82K
R21	330K	680K

MOVING COIL DISC MODULE

Part No.	Description	Circuit Reference
C100NJS	Capacitor 100nF 5 250V B32561	C13, C14
C100UME	Capacitor 100 μ F 20% 6.3V K Mat	C3, C4
C2U2OKT	Capacitor 2.2 μ 10 16V Tant	C10, C12, C15, C16
C33NOJS	Capacitor 33nF 5 250V B32561	C9, C11
D071CPX	Int CCT TL071CP	IC1, IC2
DBC4406	Transistor BC440-6	TR2, TR4
DBC4606	Transistor BC460-6	TR1, TR3
DZ7V5AA	Zener Diode BZY88C7V5	D1, D2
FPS907A	Screen Pin	
I12542A	PCB Disc Moving Coil Module	
IWT05XX	Transistor Pad T05-009D	
M12235A	Screen	
M12443A	Disc Input Plate	
PAM8634	Gold Board Socket	1, 3, 4, 5, 7
PQ1124A	Terminal Screw + Earth Symbol	
PS05DNB	Socket 5 pin DIN Angle Panel	SK1
R100KG1	Resistor 100K 2 050	R15, R16
R12KOG1	Resistor 12K 2 050	R19, R20
R1K00J1	Resistor 1K 5 050	R5, R8
R1K10G1	Resistor 1K1 2 050	R23, R24
R1K50J1	Resistor 1K5 5 050	R4, R9
R3K60G1	Resistor 3K6 2 050	R27, R28
R4K70J1	Resistor 4K7 5 050	R3, R6, R7, R10, R11, R12
R6K80J1	Resistor 6K8 5 050	R25, R26
TC205PF	Drive Screw 3/16 2Z Sup Black	
PSPHON2	Socket Phono Red	
PSPHON9	Socket Phono White	

Varying Capacitance & Resistance Values

R6R80G1	Resistor 6.8 2	M/C B, D, E, R13, R14
R22ROG1	Resistor 22 2	M/C A, C, F, R13, R14
R100RJ1	Resistor 100 5	M/C B, C, E, F, R1, R2
R470RJ1	Resistor 470 5	M/C A, D, R1, R2
R68K0J1	Resistor 68K 5	M/C A, C, F, R17, R18
R100KJ1	Resistor 100K 5	M/C B, D, E, R17, R18
R560KG1	Resistor 560K 2	M/C A, C, F, R21, R22
RIM20G1	Resistor 1M2 2	M/C B, D, E, R17, R18
C1U50KS	Capacitor 1.5 μ F 10 100V	M/C E, F, C1, C2
C22NOJS	Capacitor 22nF 10 250V	M/C A, D, C1, C2
C68NOKS	Capacitor 68n 10 400V	M/C B, C, C1, C2
C47UOKT	Capacitor 47 μ 10 3V	M/C A, C, F, C5, C6, C7, C8
C68UOKT	Capacitor 68 μ 10 3V	M/C B, D, E, C5, C6, C7, C8

tape input/output

M12496 ISS 3

Qty	Ref. No.	Stock No.	Description
2	TR1, TR2	DE5270X	Transistor E5270
2	IC1, IC2	D071CPX	Integrated circuit TL071
2	S1-S8	S44DILA	'DIL' Switch DYS-4DS
4	R1, R2, R29, R30	RIM00J1	Resistor 1M \pm 5%
4	R3, R4, R7, R8	RIK00J1	Resistor 1K \pm 5%
2	R5, R6	R6K80J1	Resistor 6K8 \pm 5%
2	R9, R10	R110RJ1	Resistor 110 \pm 5%
2	R11, R12	R33R0J1	Resistor 33 \pm 5%
2	R13, R14	R33K0J1	Resistor 33K \pm 5%
2	R15, R16	R18K0J1	Resistor 18K \pm 5%
2	R17, R18	R3K00J1	Resistor 3K \pm 5%
2	R19, R20	R820R1J1	Resistor 820 \pm 5%
2	R21, R22	R82K0J1	Resistor 82K \pm 5%
2	R23, R24	R39K0J1	Resistor 39K \pm 5%
2	R25, R26	RIK50J1	Resistor 1K5 \pm 5%
2	R27, R28	R4K70J1	Resistor 4K7 \pm 5%
2	C1, C2	C100NKS	Capacitor .1 μ 100V
2	C3, C4	C100UKU	Capacitor 100 μ 3V
2	C5, C6	C470NKS	Capacitor .47 μ 100V
2	C7, C8	C680NKS	Capacitor .68 μ 100V
1	SK1	PO5DNSB	5 pin DIN socket
1		112496A	Printed board to Drg. M12496
7	1-7	PAM8634	Board socket AMP 85863-4

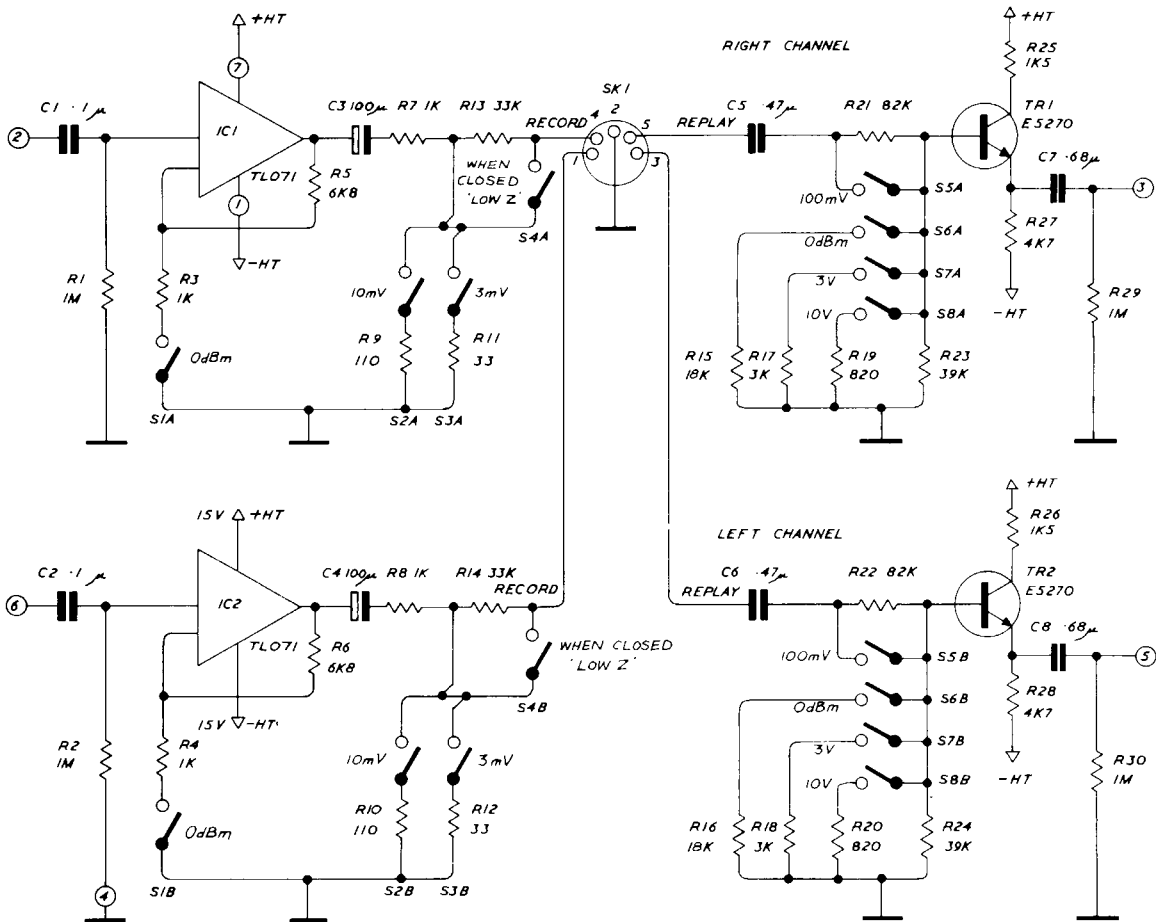
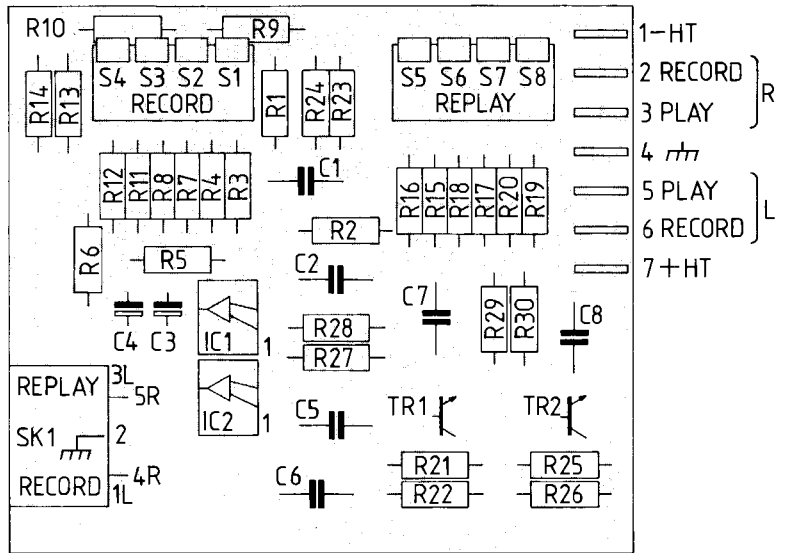

QUAD 44 service data

modifications

ORIGINAL ISSUE BOARD M12496 – ISS 3 COMPONENT ALTERNATIVES

IC1 IC2 – LM351, TL071.

TAPE MODULE

Part No.	Description	Circuit Reference
C100NKC	Capacitor 100nF 10 250V B32561	C1, C2
C100UKT	Capacitor 100 μ F 10 3V Tant	C3, C4
C470NKS	Capacitor 470nF 10 100V B32561	C5, C6
C680NKS	Capacitor 680nF 10 100V B32561	C7, C8
DE5270X	Transistor E5270	TR1, TR2
PS05DNB	Socket 5 pin DIN Angle Panel	SK1
D071CPX	Int Cct TL071CP	IC1, IC2
I12496A	PCB Tape Module M12496-3	
M12445A	Tape Input Plate	
PAM8634	Gold Board Socket	1, 2, 3, 4, 5, 6, 7
R110RJ1	Resistor 110 5 050	R9, R10
R18K0J1	Resistor 18K 5 050	R15, R16
R1K00G1	Resistor 1K 2 050	R3, R4, R7, R8
R1K50J1	Resistor 1K5 5 050	R25, R26
R1M00J1	Resistor 1M 5 050	R1, R2, R29, R30
R33K0J1	Resistor 33K 5 050	R13, R14
R33R0J1	Resistor 33 5 050	R11, R12
R39K0J1	Resistor 39K 5 050	R23, R24
R3K00J1	Resistor 3K 5 050	R17, R18
R4K70J1	Resistor 4K7 5 050	R27, R28
R6K80J1	Resistor 6K8 5 050	R5, R6
R820RJ1	Resistor 820 5 050	R19, R20
R82K0J1	Resistor 82K 5 050	R21, R22
S44DILA	Switch DIL DYS-4DS	S1 to S4, S5 to S8
TC205PF	Drive Screw 3/16 2Z Sup Black	

radio input

M12511 - ISS 1

Qty	Ref. No.	Stock No.	Description
2	IC200, IC201	D071CPX	Integrated circuit TL071
4	R200, R201, R206, R207	R1M00J1	Resistor 1M $\pm 5\%$
2	R202, R203	R2K20J1	Resistor 2K2 $\pm 5\%$
2	R204, R205	R3K30J1	Resistor 3K3 $\pm 5\%$
2	C200, C201	C100NKS	Capacitor .1 μ
2	C202, C203	C680NKS	Capacitor .68 μ
1	SK200	PS05DNB	5 pin DIN socket
5	1.3.4.5.7.	PAM8634	Board socket
1		I12511A	Printed board to DRG M12511

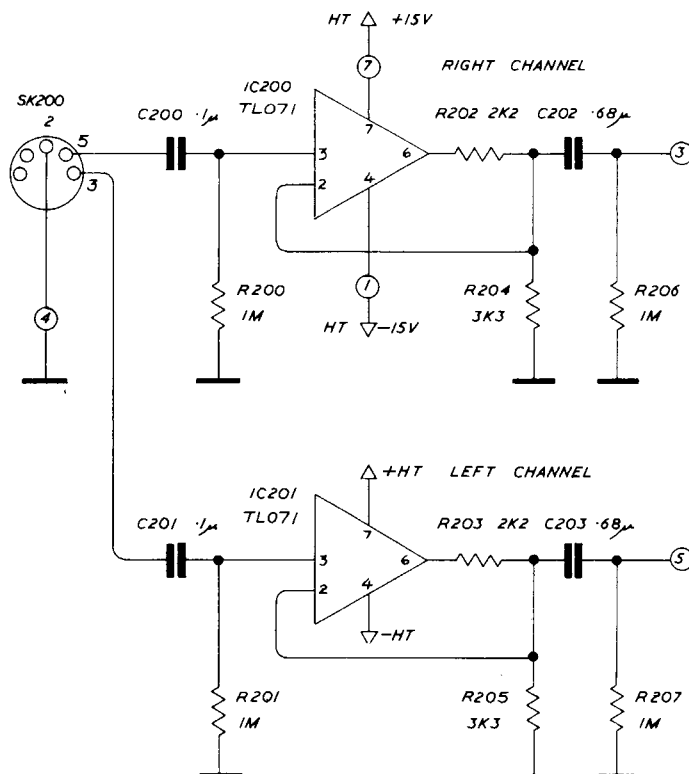
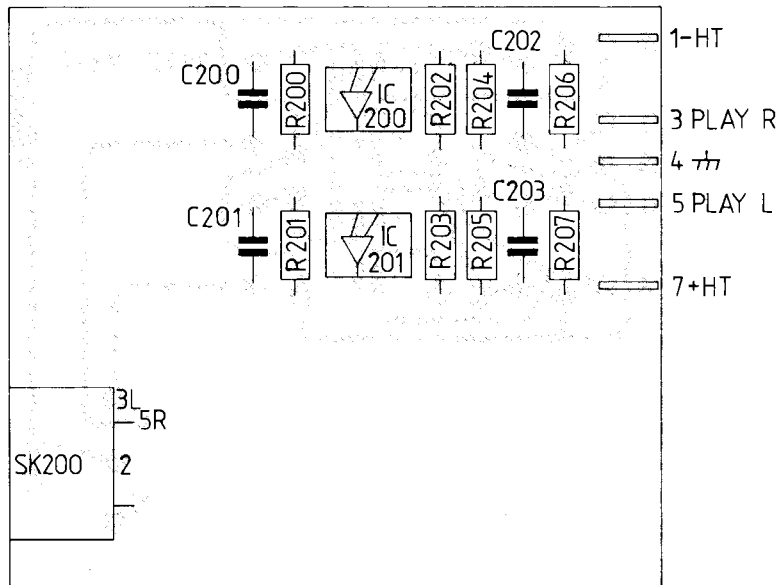

QUAD 44 service data

radio input

M12511 – ISS 2

Qty	Ref. No.	Stock No.	Description
2	IC200, IC201	D07ICPX	Integrated circuit TL071
4	R200, R201, R206, R207	R1M00J1	Resistor 1M $\pm 5\%$
2	R202, R203	R2K20J1	Resistor 2K2 $\pm 5\%$
2	R204, R205	R3K3J1	Resistor 3K3 $\pm 5\%$
2	C200, C201	C100NKS	Capacitor 100n
2	C202, C203	C680NKS	Capacitor 680n
1	SK200	P05DNSB	5 pin DIN socket
5	1.3.4.5.7	PAM8634	Board socket
1		I12511A	Printed board to DRG M12511

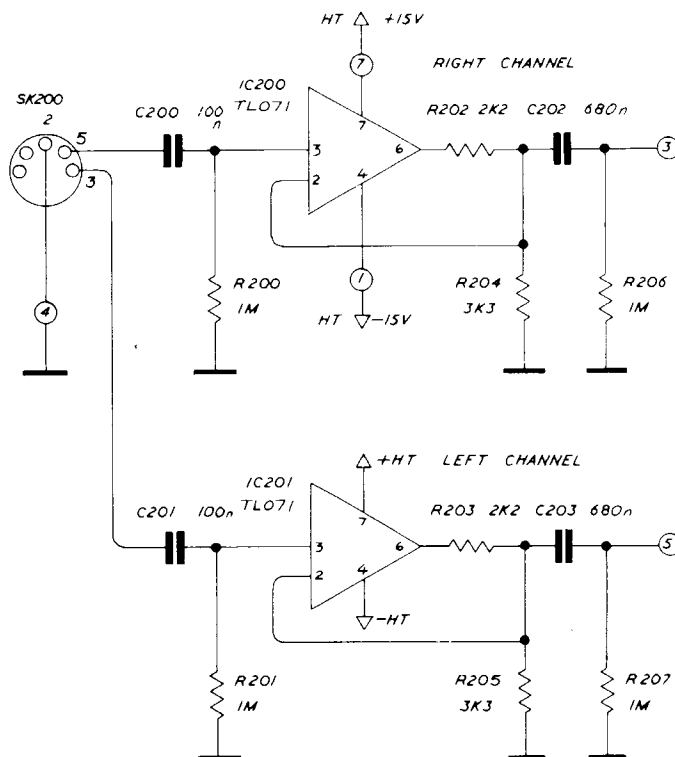
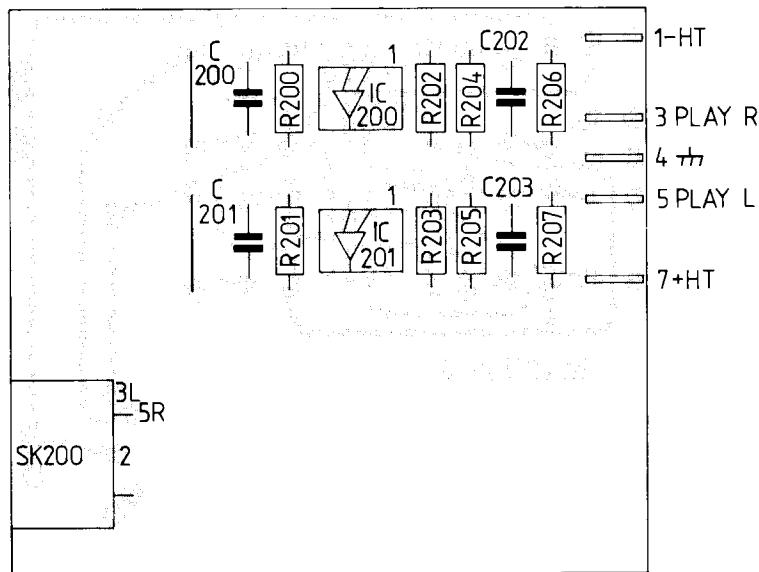

auxiliary input

M12511 – ISS 2

Qty	Ref. No.	Stock No.	Description
2	IC600, IC601	DO71CPX	Integrated Circuit TL071
2	R600, R601	R390KJ1	Resistor 390K ±5%
2	R602, R603	R100KJ1	Resistor 100K ±5%
2	R604, R605	R2K20J1	Resistor 2K2 ±5%
2	R606, R607	R3K30J1	Resistor 3K3 ±5%
2	R608, R609	R1M00J1	Resistor 1M ±5%
2	C600, C601	C100NKS	Capacitor 100n
2	C602, C603	C680NKS	Capacitor 680n
1	SK600	P05DNSB	5 Pin DIN Socket
2	SK601, SK602	PHONSRJ	'Phono' Socket
5	1.3.4.5.7	PAM8634	Board Socket
1		I12511A	Printed Board to DRG M12511

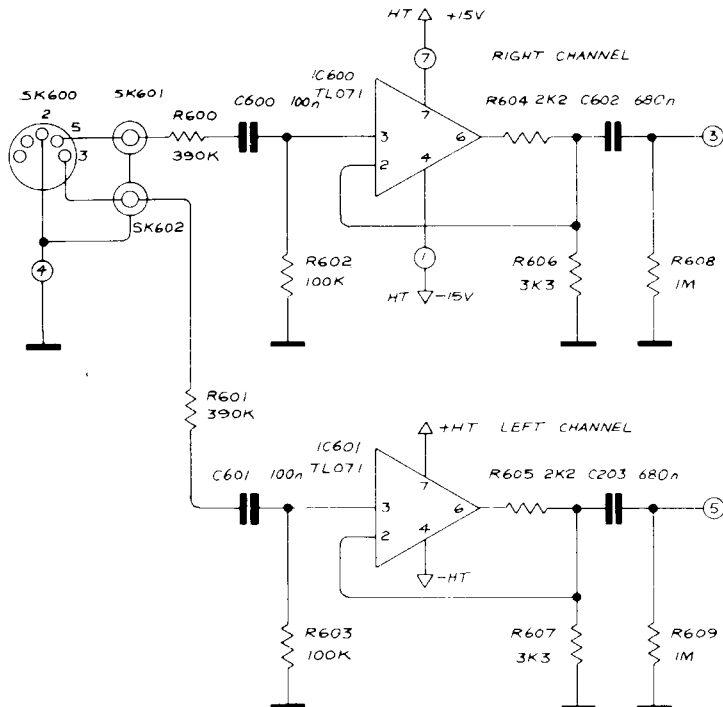
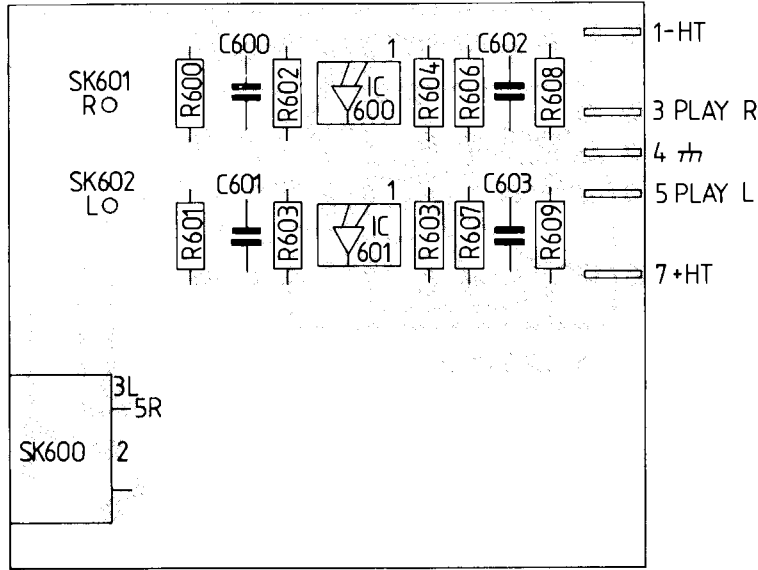

modifications

ORIGINAL ISSUE BOARD M12511 – ISS 1 M12511 ISS 2 at serial number 12000.

44's before serial number 12,000 were fitted with two radio input modules. One of the radio input modules has been replaced by an auxiliary input module. The same printed circuit board is used for both radio and auxiliary modules although the values of some of the components are different.

The auxiliary input module accommodates two types of input connector, DIN and PHONO.

ALTERNATIVE COMPONENTS

IC 200, 201, 600, 601 – LM351 or TL071.

RADIO/AUX. INPUT MODULE

Part No.	Description	Circuit Reference
C100NKC	Capacitor 100nF 10 250V B32561	C600, C601, C200, C201
C680NKS	Capacitor 680nF 10 100V B32561	C602, C603, C202, C303
PS05DNB	Socket 5 pin DIN Angle Panel	SK600, SK200
PSPHON2	Phono Socket Red	SK601
PSPHON9	Phono Socket White	SK602
D071CPX	Int Cct TL071CP	IC200, IC201, IC600, IC601
I12511A	PCB Radio/Aux Board M12511 ISS 2	
M12563A	Aux. Module Front Plate	
M12445A	Radio Module Front Plate	
PAM8634	Gold Board Socket	1, 3, 4, 5, 7
R100KJ1	Resistor 100K 5 050	R602, R603
R1M00J1	Resistor 1M 5 050	R608, R609, R200, R201, R206, R207
R2K20J1	Resistor 2K2 5 050	R604, R605, R202, R203
R390KJ1	Resistor 390K 5 050	R600, R601
R3K30J1	Resistor 3K3 5 050	R606, R607, R204, R205
TC205PF	Drive Screw 3/16 2Z Sup Black	

tone control

M12512 - ISS 8

Qty	Ref. No.	Stock No.	Description
4	IC500, IC502, IC503, IC501	D071CPX	Integrated circuit TL071
2	TR500, TR501	DE5270X	Transistor E5270
2	C531, C532	C3P30KE	Capacitor 3.3p
2	C504, C505	CU047ZL	Capacitor 47n 63V
4	C502, C503, C520, C521	C47P0KE	Capacitor 47p
2	C500, C501	C680NKS	Capacitor .68 μ
4	C518, C519, C524, C525	C68N0KS	Capacitor 68n
2	C506, C507	C6N80KS	Capacitor 6.8n
2	C508, C509	C33N0JS	Capacitor 33n
4	C510, C511, C512, C513	C100NKS	Capacitor .1 μ
2	C514, C515	C3N90KS	Capacitor 3.9n
2	C516, C517	C220NKS	Capacitor .22 μ
2	C526, C527	C15N0KS	Capacitor 15n
2	C522, C523	C100UKU	Capacitor 100
1	C528	C47U0ZB	Capacitor 47 μ 40V
1	C529	C27P0KE	Capacitor 27p
1	C530	C3P30CI	Capacitor 3.3p
1	D500	BLLLL7X	LED LLL7
4	R514, R515, R522, R523	R22K0J1	Resistor 22K \pm 5%
4	R500, R501, R546, R548	R6K80G1	Resistor 6K8 \pm 2%
3	R504, R505, R556	R1K00J1	Resistor 1K \pm 5%
4	R506, R507, R536, R537	R100KJ1	Resistor 100K \pm 5%
2	R508, R509	R82KJ1	Resistor 82K \pm 5%
2	R510, R511	R39KJ1	Resistor 39K \pm 5%
4	R516, R517, R524, R525	R2M20J1	Resistor 2M2 \pm 5%
2	R518, R519	R12K0J1	Resistor 12K \pm 5%
4	R520, R521, R534, R535	R10K0J1	Resistor 10K \pm 5%
2	R546, R548	R9K10G1	Resistor 9K1 \pm 2%
2	R526, R527	R15K0J1	Resistor 15K \pm 5%
3	R528, R529, R550	R33K0J1	Resistor 33K \pm 5%
4	R530, R531, R544, R545	R18K0J1	Resistor 18K \pm 5%
2	R532, R533	R27K0J1	Resistor 27K \pm 5%
2	R538, R539	R1K80J1	Resistor 1K8 \pm 5%
2	R540, R541	R2K20J1	Resistor 2K2 \pm 5%
4	R554, R555, R502, R503	R2K20G1	Resistor 2K2 \pm 2%
2	R542, R543	R75R0J1	Resistor 75 \pm 5%
2	R547, R549	R1K00G1	Resistor 1K \pm 2%
1	R551	R180KJ1	Resistor 180K \pm 5%
2	R552, R553	R47K0J1	Resistor 47K \pm 5%
2	R512, R513	R91K0J1	Resistor 91K \pm 5%
2	L500, L501	Q44FLPA	Filter coil
1	VR500/1	R44VOLA	Volume control
1	VR502/3	R44SLOA	Slope control
1	VR504/5	R44BALA	Balance control
1	S500/1	S44FILA	Filter cancel switch
1	S502	S44TILA	Tilt switch
1	S503	S44BASA	Bass switch
1		I12512A	Printed wiring board

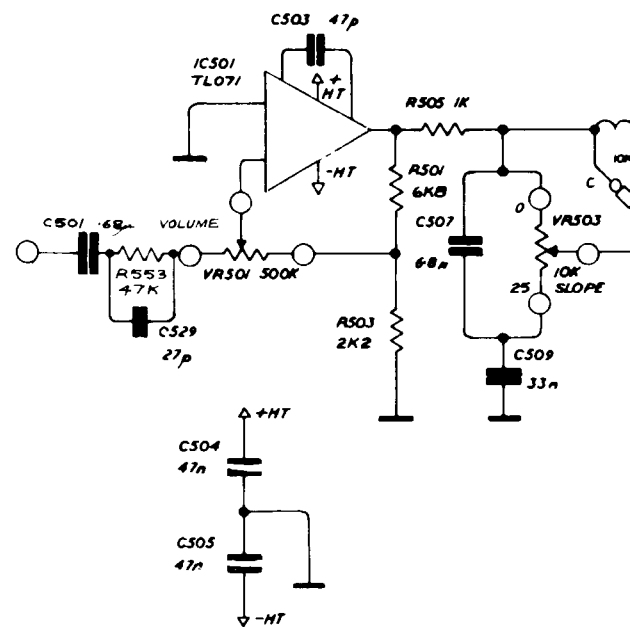
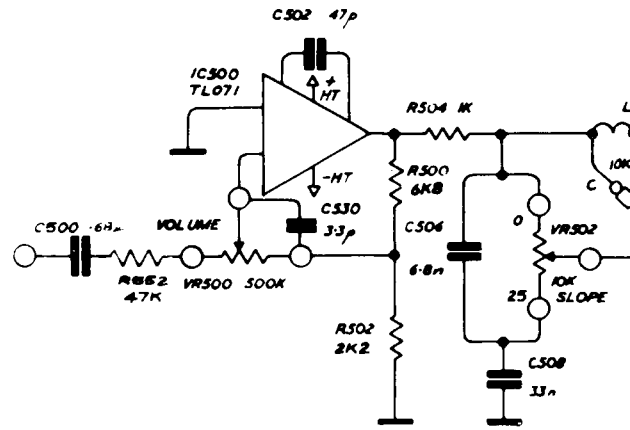

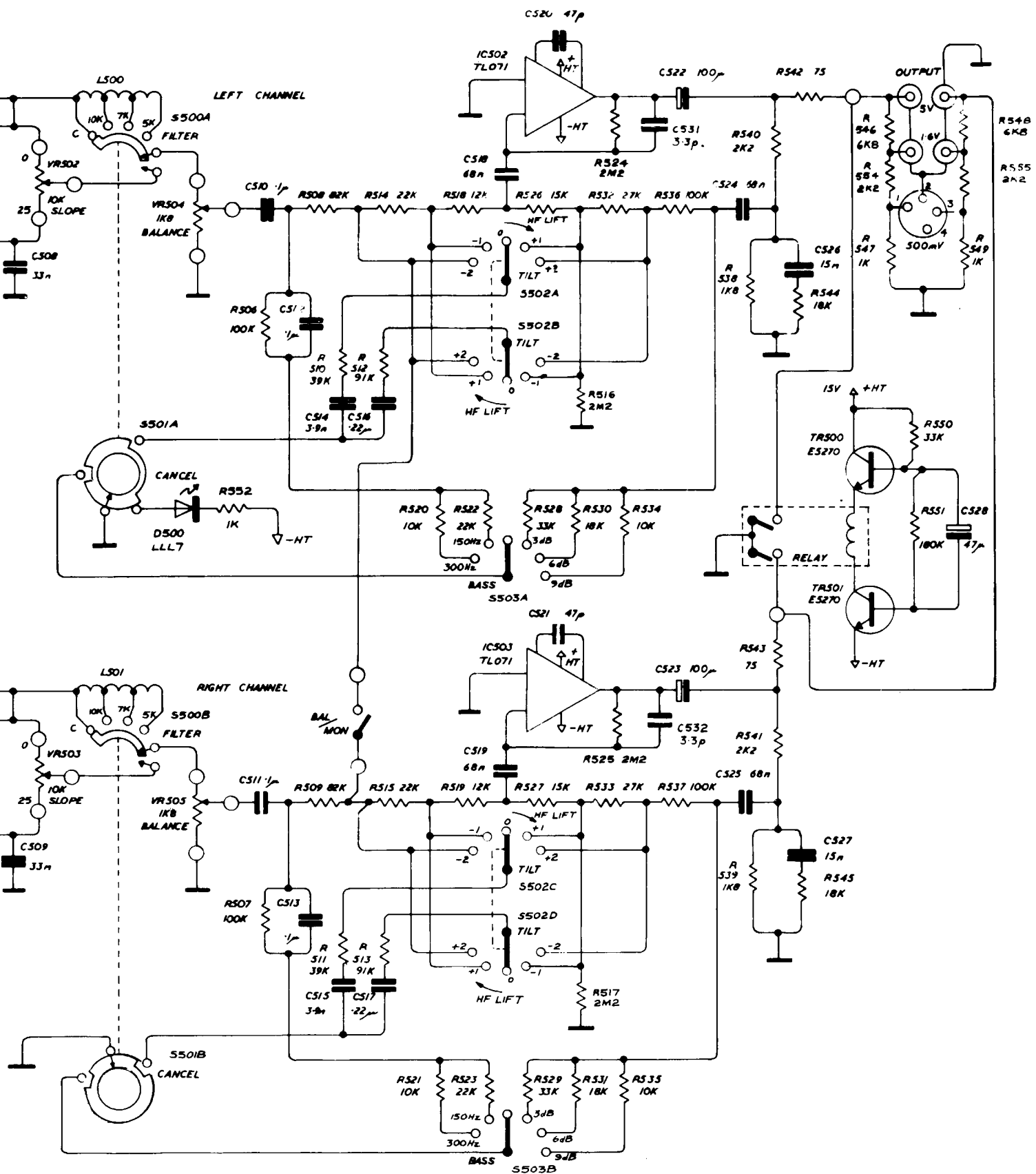

tone control

M12512 – ISS 9

Qty	Ref. No.	Stock No.	Description
4	IC500, IC502, IC503, IC501	D071CPX	Integrated circuit TL071
2	C531, C532	C3P30KE	Capacitor 3.3p
2	C504, C505	C100NKA	Capacitor 100n
4	C502, C503, C520, C521	C47P0KE	Capacitor 47p
2	C500, C501	C680NKS	Capacitor 680n
4	C518, C519, C524, C525	C68N0KS	Capacitor 68n
2	C506, C507	C6N80KS	Capacitor 6.8n
2	C508, C509	C33N0JS	Capacitor 33n
4	C510, C511, C512, C513	C100NKS	Capacitor 100n
2	C514, C515	C3N90KS	Capacitor 3.9n
2	C516, C517	C220NKS	Capacitor 220n
2	C526, C527	C15N0KS	Capacitor 15n
2	C522, C523	C100UKU	Capacitor 100 μ
1	C529	C27P0KE	Capacitor 27p
1	C530	C3P30CI	Capacitor 3.3p
1	D500	BLLLL7X	LED LLL7
4	R514, R515, R522, R523	R22K0J1	Resistor 22K \pm 5%
4	R500, R501, R546, R548	R6K80G1	Resistor 6K8 \pm 2%
3	R504, R505, R556	R1K00J1	Resistor 1K \pm 5%
4	R506, R507, R536, R537	R100KJ1	Resistor 100K \pm 5%
2	R508, R509	R82KJ1	Resistor 82K \pm 5%
2	R510, R511	R39KJ1	Resistor 39K \pm 5%
4	R516, R517, R524, R525	R2M20J1	Resistor 2M2 \pm 5%
2	R518, R519	R12K0J1	Resistor 12K \pm 5%
4	R520, R521, R534, R535	R10K0J1	Resistor 10K \pm 5%
2	R546, R548	R9K10G1	Resistor 9K1 \pm 2%
2	R526, R527	R15K0J1	Resistor 15K \pm 5%
2	R528, R529	R33K0J1	Resistor 33K \pm 5%
4	R530, R531, R544, R545	R18K0J1	Resistor 18K \pm 5%
2	R532, R533	R27K0J1	Resistor 27K \pm 5%
2	R538, R539	R1K80J1	Resistor 1K8 \pm 5%
2	R540, R541	R2K20J1	Resistor 2K2 \pm 5%
4	R554, R555, R502, R503	R2K20G1	Resistor 2K2 \pm 2%
2	R542, R543	R75R0J1	Resistor 75 \pm 5%
2	R547, R549	R1K00G1	Resistor 1K \pm 2%
2	R552, R553	R47K0J1	Resistor 47K \pm 5%
2	R512, R513	R91K0J1	Resistor 91K \pm 5%
2	L500, L501	Q44F1P1	Filter coil
1	VR500/1	R44V0LA	Volume control
1	VR502/3	R44SLOA	Slope control
1	VR504/5	R44BALA	Balance control
1	S500/1	S44FILA	Filter/cancel switch
1	S502	S44TILA	Tilt switch
1	S503	S44BASA	Bass switch
1		I12512A	Printed wiring board M12512

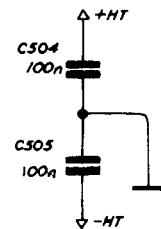
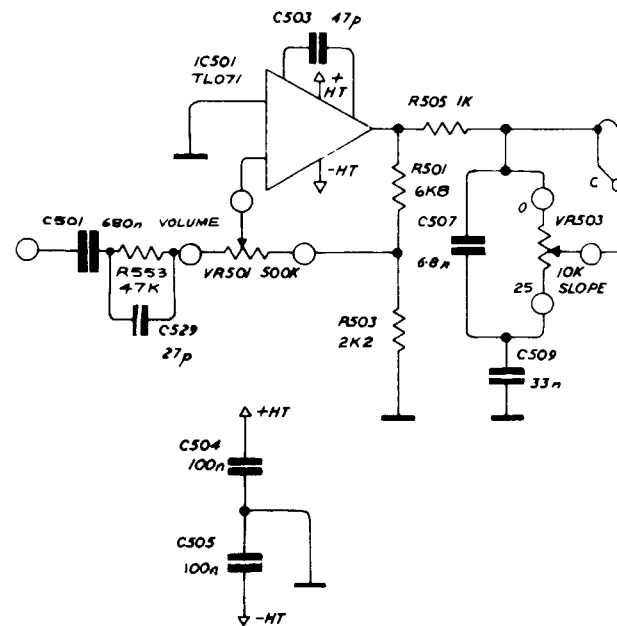
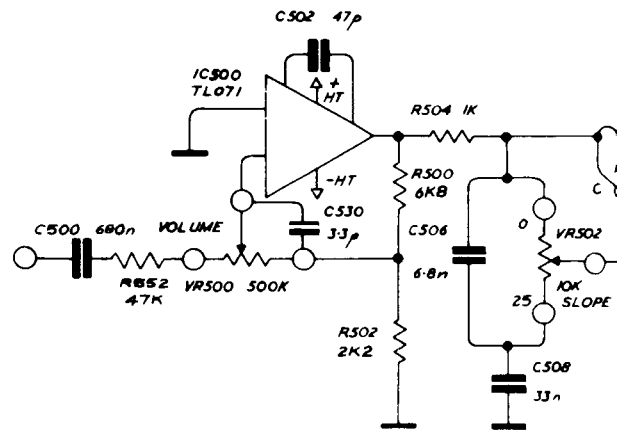

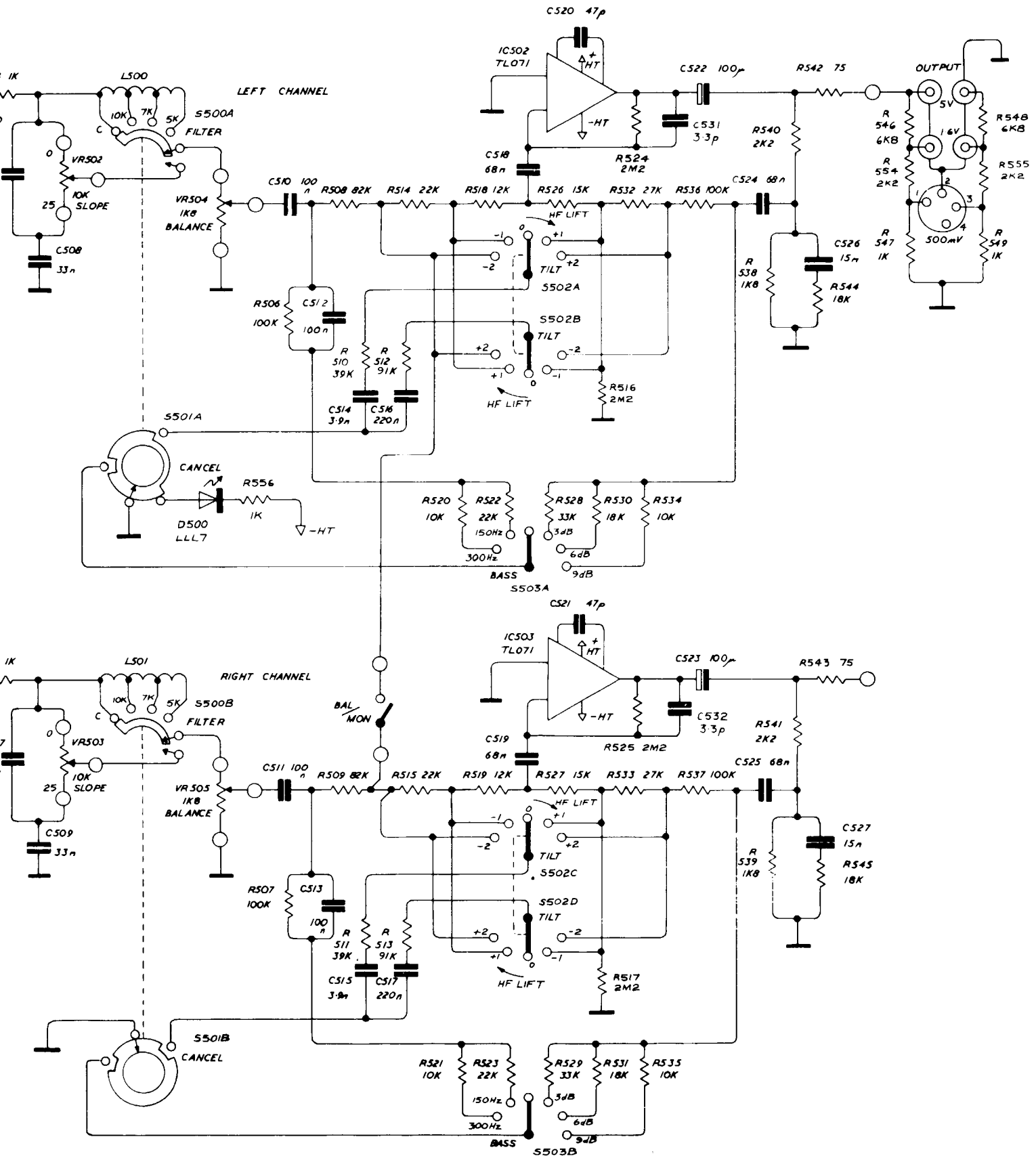

QUAD 44 service data

tone control

M12512 - ISS 9

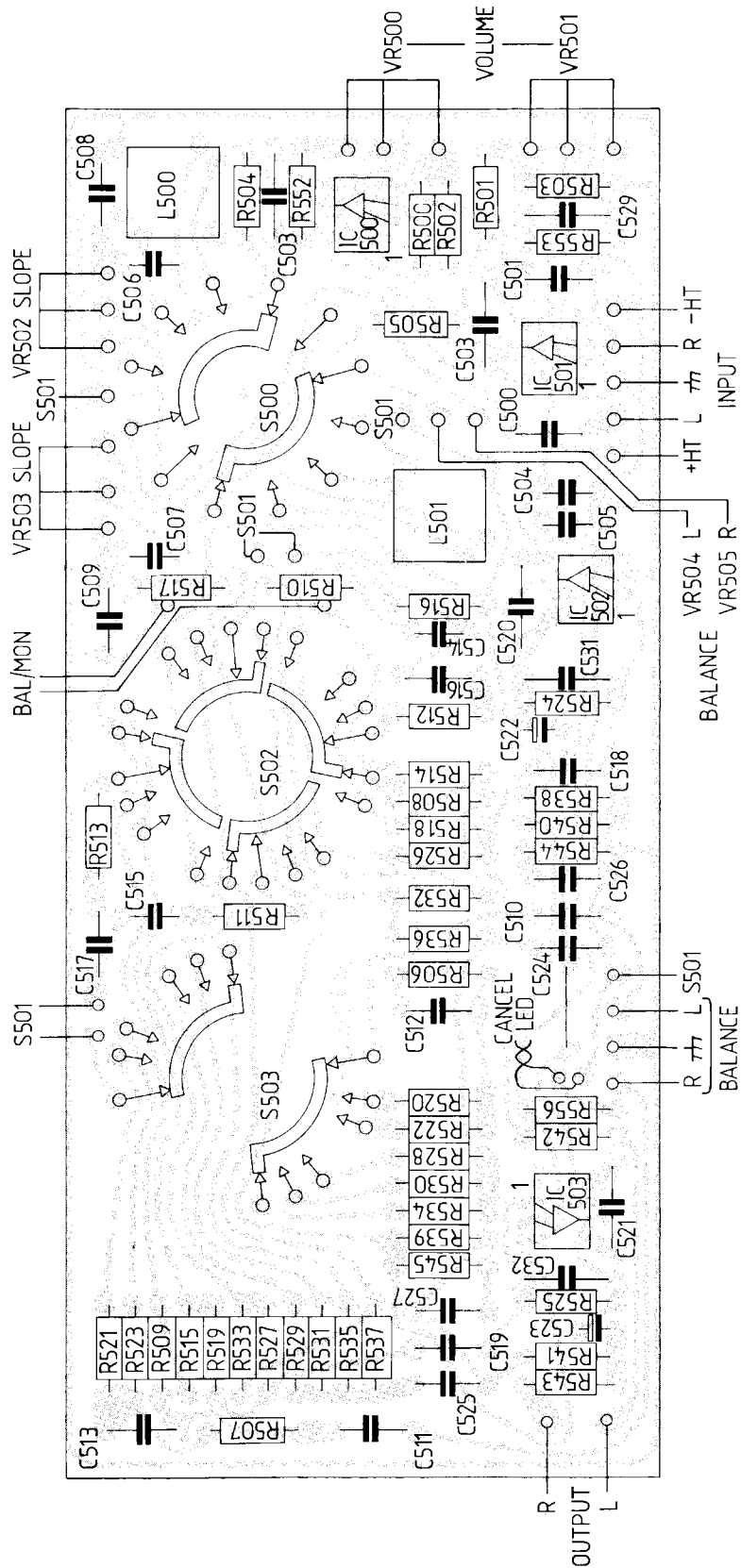

ISS. 9 M12512 TONE

modifications

ORIGINAL ISSUE BOARD M12512 ISSUE 5

C529 – 27pf added at a later stage in production.

M12512 ISS 6

As issue 5 except that the top side of the printed circuit board has an earth screen.

Changes made at serial number 2401

R500 and R501 changed from 22K to 6K8

R502 and R503 changed from 6K8 to 2K2

This increases the ultimate attenuation of the volume control to -72dB.

M12512 ISS 8

C531 and C532 added to improve stability. Other changes made at various stages in production:

1. C529-27pf removed.

2. 4.7 μ F capacitor added to the relay circuit from the +15V HT to the base of TR501, in order to increase the relay switch off time.

M12512 ISS 9 SERIAL NUMBER 12000

The board does not accommodate the relay circuit which has been modified and fitted to the mother board M12436 – ISS 5.

For 44's pre-serial number 12000 replacement relays are National HB2 - DC24V stock number SMHB2TA. These are not interchangeable with the type of relay fitted to the mother board.

C504, C505 change from 47n to 100n.

COMPONENT ALTERNATIVES

IC500, 501, 502, 503 – LM351 or TL071.

QUAD 44 service data

TONE CONTROL BOARD

Part No.	Description	Circuit Reference
C100NKC	Capacitor 100nF 10 250V B32561	C510, C511, C512, C513
C100NKS	Capacitor 100nF 10 100V B32510	C504, C505
C100UKT	Capacitor 100 μ F 10 3V Tant	C522, C523
C15NOKS	Capacitor 15nF 10 400V B32561	C526, C527
C220NKB	Capacitor 220nF 0 250V B32561	C516, C517
C33NOJS	Capacitor 33nF 5 250V B32561	C508, C509
C3N9OKS	Capacitor 3.9nF 10 400V B32545	C514, C515
C3P30KJ	Capacitor 3.3p UP125 CH 3R3 KB	C531, C532
C47P0KJ	Cap 47p 10 UP125-SL 470MB	C502, C503, C520, C521
C680NKS	Capacitor 680nF 10 100V B32561	C500, C501
C68NOKS	Capacitor 68nF 10 400V B32561	C518, C519, C524, C525
C6N8OKS	Capacitor 6.8nF 10 400V B32560	C506, C507
C3P30CI	Capacitor 3.3p	C530
CU047ZL	Capacitor 47n	C504, C505
C27P0KE	Capacitor 27p	C529
C47U0ZB	Capacitor 47 μ 40V EK	C528
C4U70ZA	Capacitor 4.7 μ 63V	
PAM1872	Male Tags	
PAM3702	Black Pin Cluster - 2 way	
D071CPX	Int Cct TL071CP	IC500, IC501, IC502, IC503
I12512A	PCB Tone Board M12512 ISS 9	
M12484A	Pillar	
M12485A	Slope Control Bracket	
PAM0358	Black Self-retaining Skt 2 way	
P19308A	I C Holder C930802	
R100KJ1	Resistor 100K 5 050	R506, R507, R536, R537
R10K0J1	Resistor 10K 5 050	R520, R521, R534, R535
R12K0J1	Resistor 12K 5 050	R518, R519
R15K0J1	Resistor 15K 5 050	R526, R527
R180KJ1	Resistor 180K 5 050	R551
R18K0J1	Resistor 18K 5 050	R530, R531, R544, R545
R1K00J1	Resistor 1K 5 050	R504, R505, R556
R1K80J1	Resistor 1K8 5 050	R538, R539
R22K0J1	Resistor 22K 5 050	R514, R515, R522, R523
R27K0J1	Resistor 27K 5 050	R532, R533
R2K20G1	Resistor 2.2K 2 050	R502, R503, R554, R555
R2K20J1	Resistor 2K2 5 050	R540, R541
R2M20KI	Resistor 2.2M 10 050	R516, R517, R524, R525
R33K0J1	Resistor 33K 5 050	R528, R529, R550
R39K0J1	Resistor 39K 5 050	R510, R511
R44SLOA	Potentiometer Slope Control	VR502, VR503
R47K0J1	Resistor 47K 5 050	R552, R553
R6K80G1	Resistor 6K8 2 050	R500, R501, R546, R548
R75ROJ1	Resistor 75 5 050	R542, R543
R82K0J1	Resistor 82K 5 050	R508, R509
R91K0J1	Resistor 91K 5 050	R512, R513
S44BASA	Switch Bass Control	S503
S44FILA	Switch Filter	S500
S44TILA	Switch Tilt Control	S502
TM206PA	Screw M2.5 6mm Sup. Pan. St. BZP	
R44BALA	Potentiometer Balance Control	VR504
R44VOLA	Potentiometer Volume Control	VR500
Q44FLPA	Filter Coil	L500, L501
SMHB2TA	Relay HB2 24D.C.	Do not use on Q44 after Serial Number 12,000
DE5270X	Transistor E5270	TR500, TR501

miscellaneous modifications

From serial number 2400 to 3175, some 44's used improved connectors on the red and white twined wires, between the mother board and tone-control board.

The wires on 44's pre-serial number 2400 had been soldered to the tone control board, and semi permanently fixed to the mother board using a green 3-way pin and socket cluster.

On some 44's between serial number 2,400 and 3175 the wires were soldered to the mother board, and semi-permanently fixed to the tone control board using spade type connectors.

Co-incident with the introduction of the Issue 4 mother board M12436, the wires were again soldered to the tone control board, and semi-permanently fixed to the mother board using spade type connectors.

SERIAL NUMBER 4851

A 1.6V output level is now fitted to the output panel alongside the 5V output.

Fig. 19 shows how to convert pre-serial number 4851 44's from 5V to 1.6V.

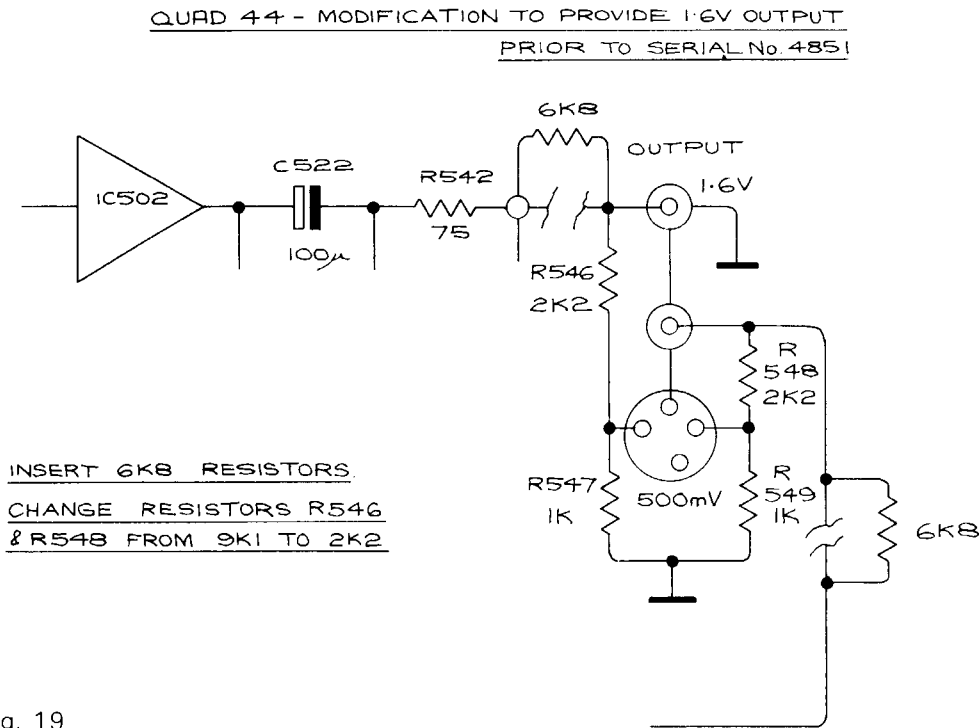

Fig. 19

SERIAL NUMBER 7001

A suppressor is now fitted across the power switch.

SERIAL NUMBER 12,000

Spade connectors and, green pin and socket clusters throughout the 44 have been replaced with an improved black pin and socket cluster.

SERIAL NUMBER 19,000

Switched AC connectors have been changed to conform with European standards. The outlets have been changed to type CEE22 moated sockets. It is important NOT to use the old type unshrouded male connector in the new type unshuttered socket. It is possible to insert the earth pin of the plug into the live output of the socket, with obvious consequences.

miscellaneous components

Part No.	Description	Circuit Reference
FF2938A	Spire Clip SFO 2938/17/00	
M12453A	44 Mains Transformer Chassis	
M12526A	44 Transformer Shroud	
N39159A	44 Mains Switch Coupling Link	
NPMR20A	Suppressor PMR209M-547-100 D N	
PF5234A	Fuseholder 5234	
PPF579A	Plug 3 pin AC Eur. Input - Panel	Use on units before Serial Number 19,000
PSP680A	Skt 3 pin AC Outlet Panel P680	Use on units before Serial Number 19,000
S44M/SA	AC Voltage Selector	
S44OFFA	AC On Off Switch 240V	
TC406PC	Drive Screw 1/4 4Z Sup Pan	
TM308CA	Screw M3 8mm Sup. Csk. ST. BZP	
TM316PA	Screw M3 16mm Sup. Pan. ST. BZP	
UMA10DA	Fuse 20mm 100mA Delay 5704	
PPR0331	Plug 3 pin AC Eur. Input	F400
PSR0431	Skt 3 pin AC Outlet	Use on units from Serial Number 19,000
L12527A	Transf. 44 AC Supply A4/12527	Use on units from Serial Number 19,000
M12447A	44 AC Supply Box and Cover	T400
FFLOKAB	Lokut Nut 212-110302-00	
PS04DNA	Socket 4 pin DIN Panel Mntg	
PSPHON2	Socket Phono Red AT700NP	
PSPHON9	Socket Phono White AT700NP	
R1K00G1	Resistor 1K 2 050	R547, R549
R2K20J1	Resistor 2K2 5 050	R554, R555
R6K80G1	Resistor 6K8 2 050	R546, R548 After Serial Number 4850
TM206PB	Screw M2.5 6mm Sup. Pan. ST. BLK	
TM2FHFA	Nut M2.5 Full Hex ST. BZP	
R9KI0J1	Resistor 9K1 5 050	R546, R548 Up to Serial Number 4850

Part No.	Description	Circuit Reference
AF588AA	Rubber Feet B8/588	
FE1210A	Eyelet L51210 Med. Brass Yellow	
FF123ZF	Push-on Fix HPW 123 ZF	
FF1722A	Quad Insert Securing Clip	
FP70271	Card Securing Clip	
I12514A	PCB LED 12514	
IFVF88A	Sponge Strip	
M12430A	Pushbutton Caps	
M12435P	Front Panel	
M12439A	Side Panel	
M12440A	Top Chassis Rail	
M12440B	Bottom Chassis Rail	
M12448P	Knob Vol. Contr.	
M12449P	Knob Slope Con.	
BLLLL7X	Cancel LED	D500
M12450P	Knob Tone Con.	
M12451P	Knob Filter	
M12452P	Sub Panel	
M12471P	Cover	
M12472A	Spacer	
M12474A	Mains Sw. Conn. Link	
M12477A	Balance Control Knob	
M12478P	Bal-Mon Plate	
M12479A	Quad Insert	
M12480A	Cover Escutcheon	
M12481A	Cover Lid	
M12490A	Dil Cover Card	
M12510A	Transf. Shield	
M12537A	Balance Slider Screen	
M12562A	Cover Chassis Supports	
N36325A	Mains Switch Knob 36325	
TC306PA	Screw M3 6mm Thread Forming	
TC406PC	Drive Screw 1/4 4Z Sup Pan	
TDM4SPA	Washer M4 9 ST BZP	
TM206CA	Screw M2.5 6mm Sup. Csk. ST. BZP	
TM303GC	Grubscrew M3 3mm Socket	
TM310GC	Screw M3 10mm Grub Skt Flat	
TM408PA	Screw M4 8mm Sup. Pan ST. BZP	
TM416PA	Screw M4 16mm Sup. Pan ST. BZP	
PAM5302	Wire End Sockets Gold	
FTB65S5	Solderitag 6BA SS5	
M12438A	Front Plate	
S44BALA	Bal-Mon Switch	
TM306PA	Screw M3 6mm Sup. Pan. ST. BZP	
TM312PA	Screw M3 12mm Sup. Pan. ST. BZP	
TM3FHFA	Nut M3 Full Hex ST. BZP	

COMPLETED SUB ASSEMBLIES

Part No.	Description	Circuit Reference
Q44TOPA	P.C.B. Tone Control M12512 ISS 8	Use only on units before Serial Number 12,000
Q44TOPB	P.C.B. Tone Control M12512 ISS 9	Use only on units after Serial Number 12,000
Q44MOPB	P.C.B. Mother Board M12436 ISS 5	Use only on units after Serial Number 12,000
Q44RAPA	P.C.B. Radio Board M12511 ISS 2	
Q44AUPA	P.C.B. Aux Board M12511 ISS 2	
Q44TAPA	P.C.B. Tape Board M12496 ISS 3	
Q44DSPA	P.C.B. Disc Board M12515 ISS 4	
Q44DSP5	P.C.B. Disc Board M12515 ISS 5	
Q44DAPA	P.C.B. Disc M/C Board A M12542 ISS 3	
Q44DBPA	P.C.B. Disc M/C Board B M12542 ISS 3	
Q44DCPA	P.C.B. Disc M/C Board C M12542 ISS 3	
Q44DDPA	P.C.B. Disc M/C Board D M12542 ISS 3	
Q44DFPA	P.C.B. Disc M/C Board F M12542 ISS 3	
Q44BAPA	P.C.B. Bal-Mon Board	
Q44LEPA	P.C.B. LED Board	
Q44OPPA	Output Assembly	

QUAD 44

Circuit diagram with effect from Serial No. 23001 (March 1984)

Modifications:

- (1) Serial No. 25800 (June 85) – Mains earth connected to chassis (signal earth)
- (2) Serial No. 28500 (April 86) – Phono sockets fitted to all signal inputs and outputs.
- (3) Serial No. 29900 (Jan 87) – Voltage selector omitted. Voltage range changed by links inside power supply box.

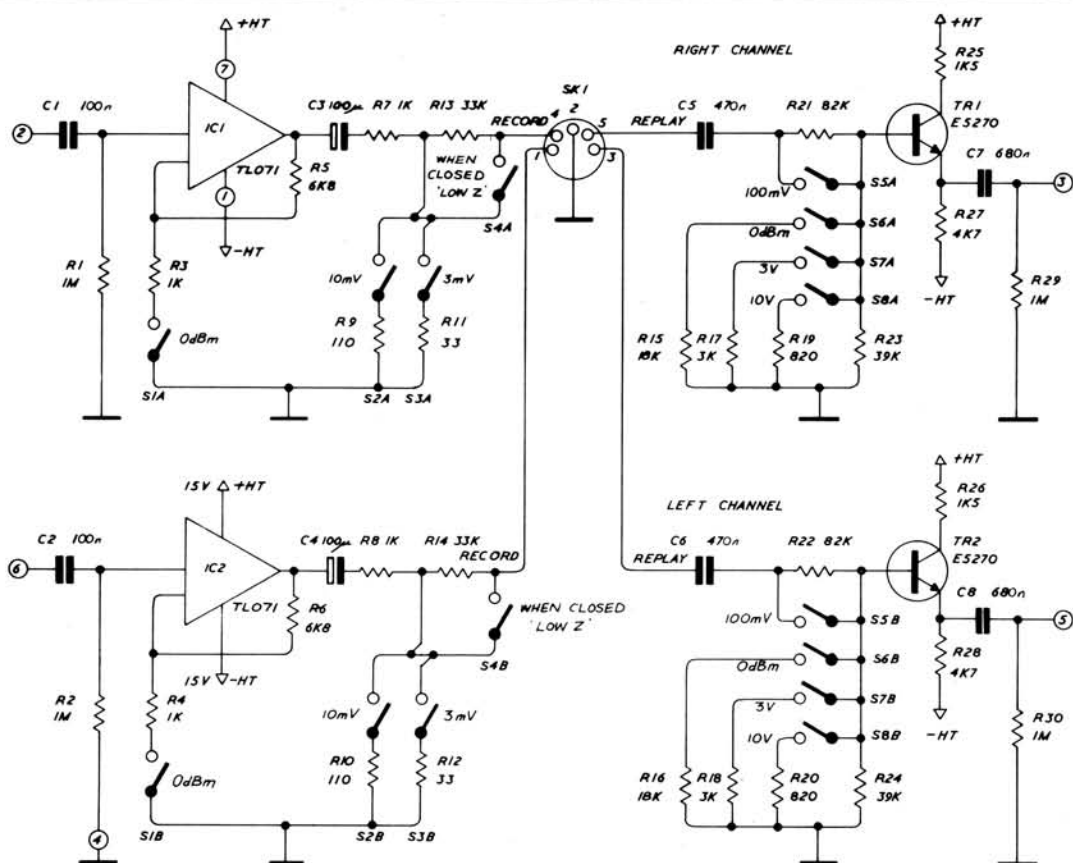

TAPE RECORD/REPLAY DRWG 12495 ISS 2 – USED WITH PCB M12496 ISS 3

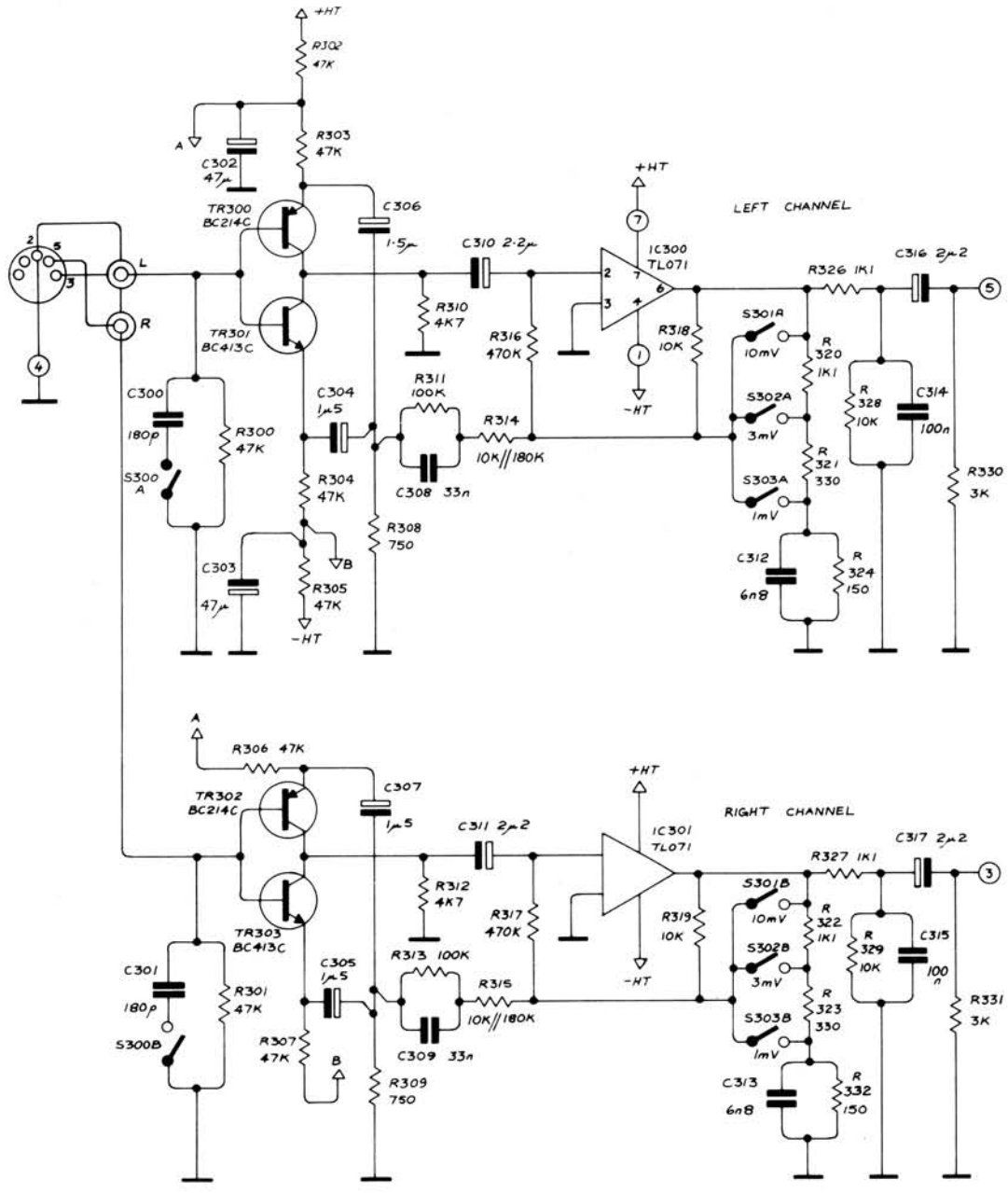

DISC DRWG 12518 ISS 2 - USED WITH PCB M12515 ISS 5

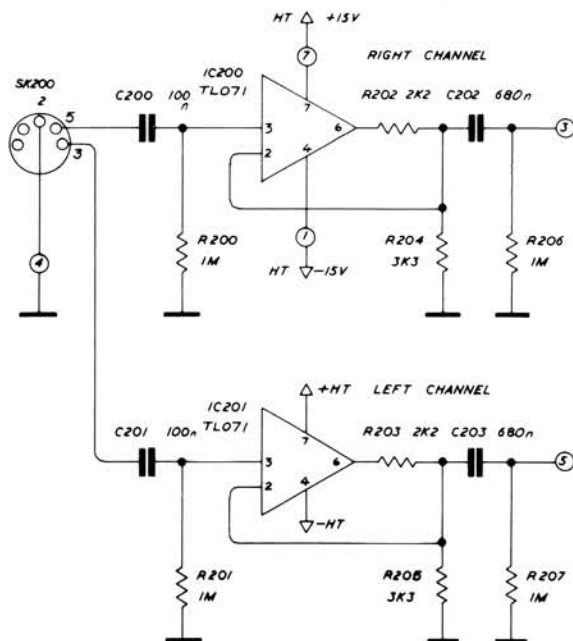

RADIO DRWG 12517 ISS 2 – USED WITH PCB M12511 ISS 2

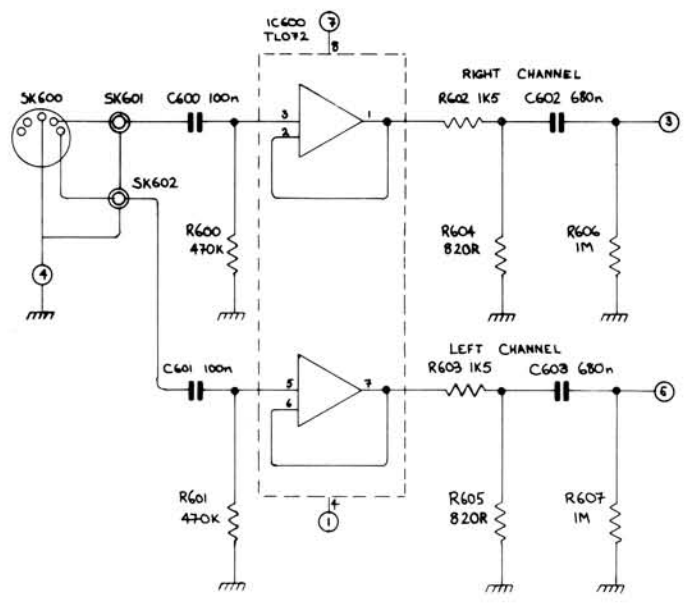

CD/AUX DRWG 12564 ISS 3 – USED WITH PCB M12815 ISS 1

MOTHER BOARD AND POWER SUPPLY
DRWG 12519 ISS 2
USED WITH
PCB M12436 ISS 5

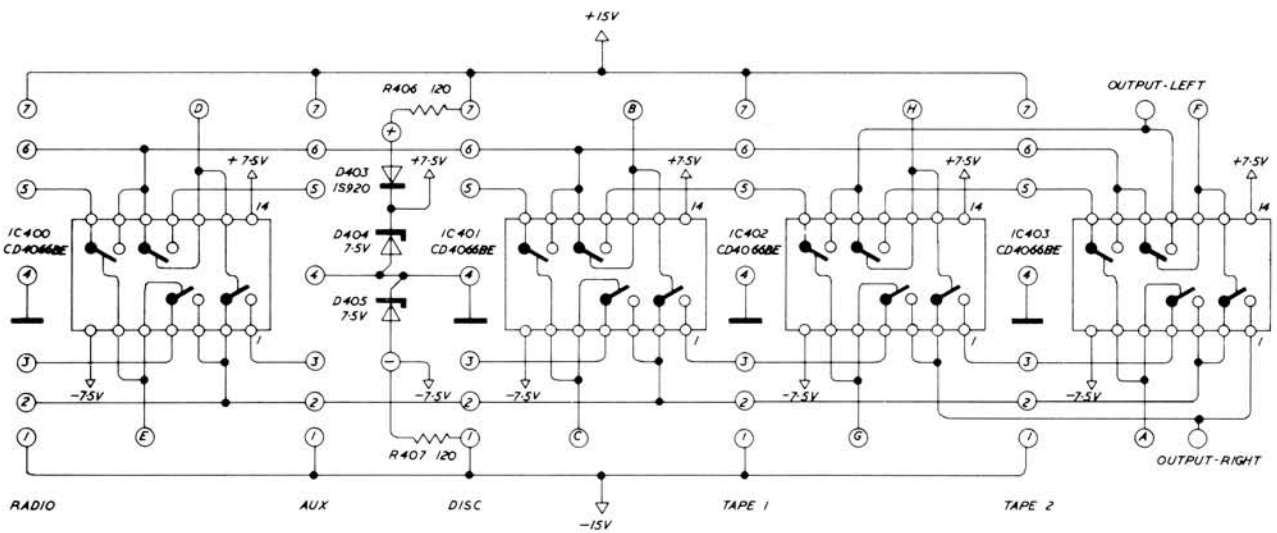
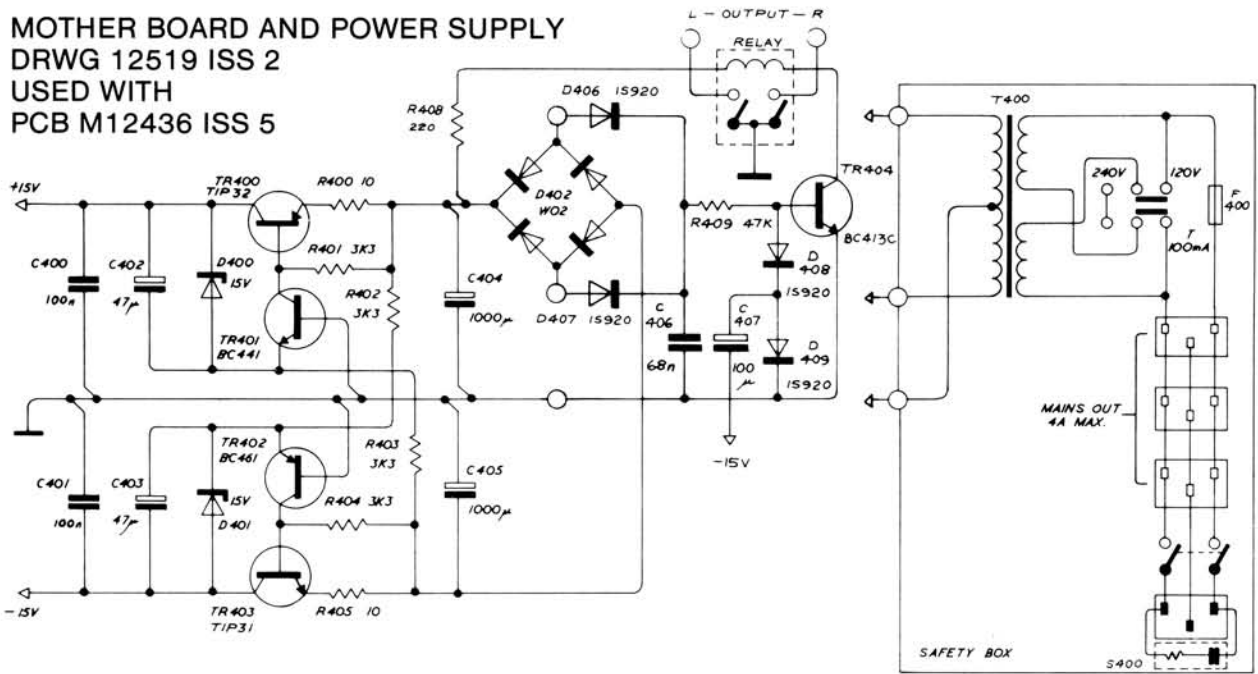

DC OUTPUT VOLTAGES TO OPERATE ELECTRONIC SWITCHES ON MOTHER BOARD

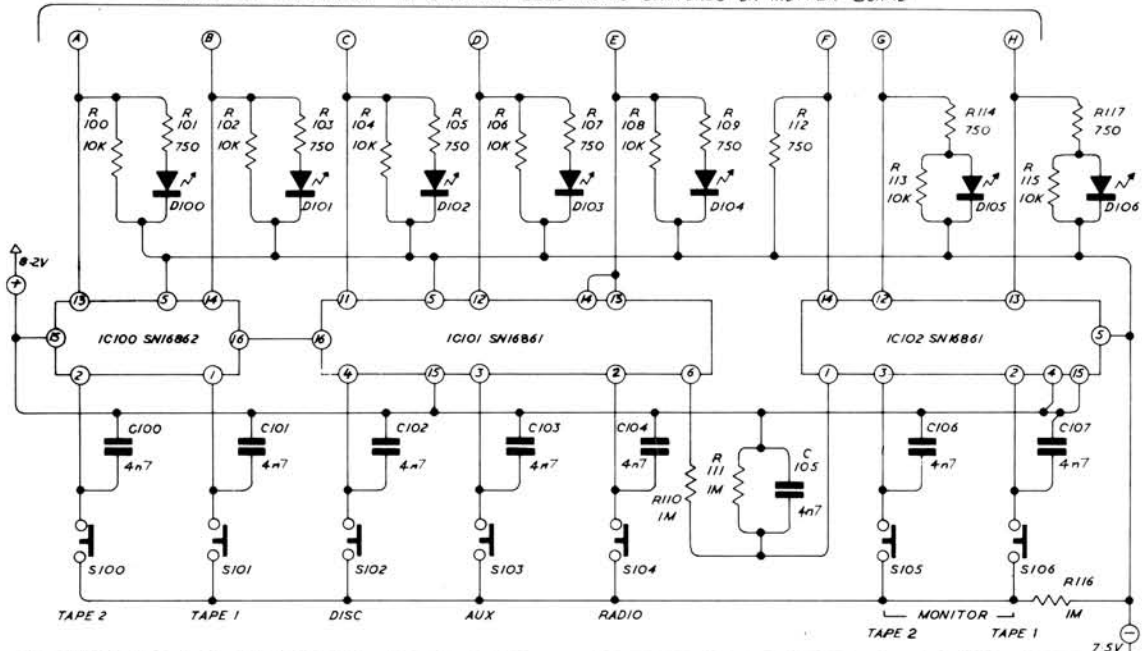

INPUT SELECTOR DRWG 12502 ISS 2 - USED WITH PCB M12428 ISS 4,5,7

VARIABLE VALUES

TYPE	4A	4B	4C
SENSITIVITY	200 μ V	100 μ V	400 μ V
R605, R606	1k2	560R	470R
R607, R608, R609, R610	12k	5k6	33k
R613, R614	10R	4R7	18R
R621, R622	820k	820k	1M
C605, C606, C607, C608	33 μ	68 μ	15 μ

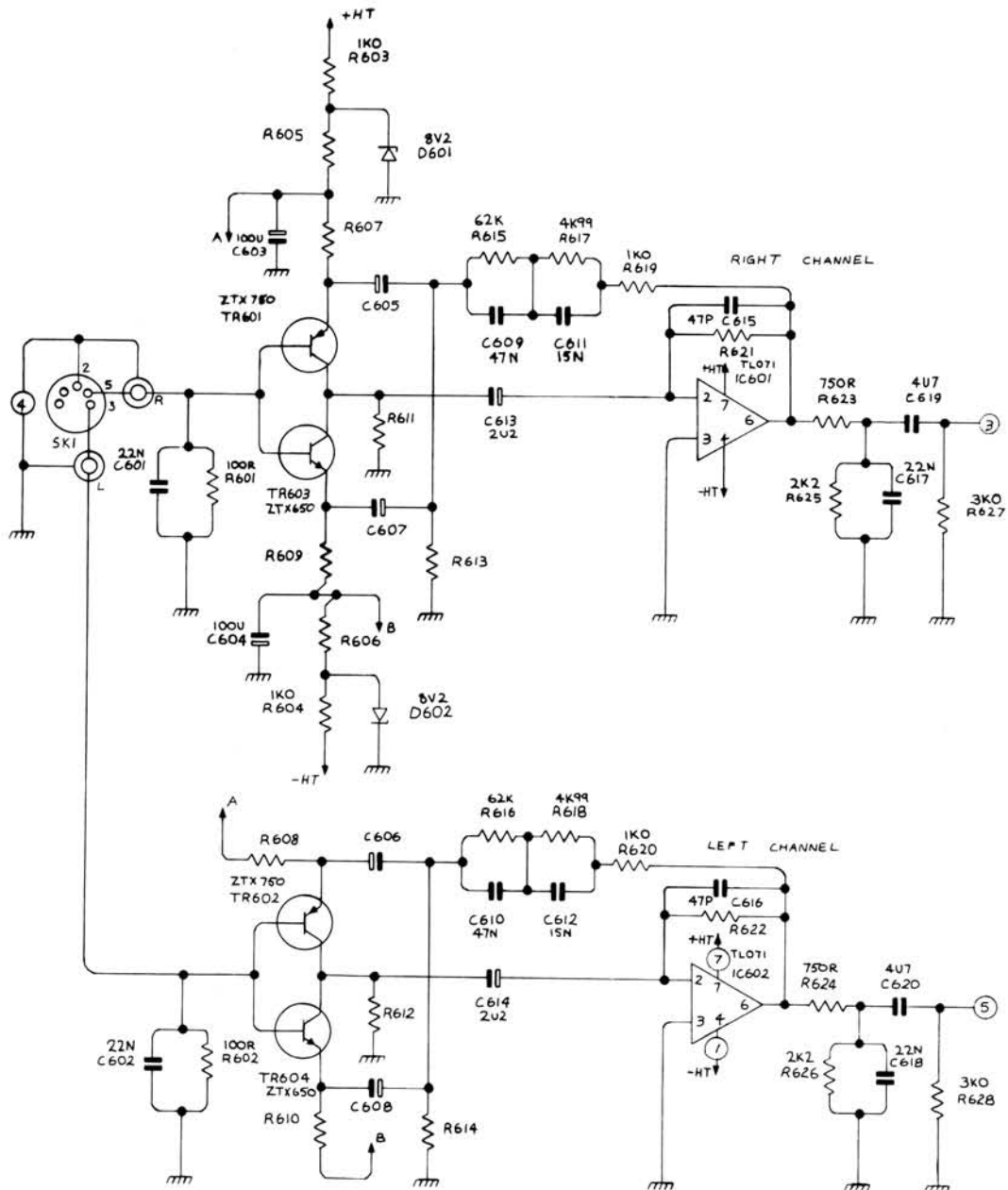

MOVING COIL DISC DRWG 12797 ISS 1 - USED WITH PCB M12542 ISS 5

QUAD 44 ERRATIC INPUT SWITCHING

A small number of 44 control units appear to be subject to pulses, triggering the electronic switching causing the unit to change from the input selected either to another input or to no input at all. The required input can then be regained by pressing the appropriate input selector button. The cure is to:

1. Resolder both sides of the 10 feed through pins marked D, E, +, -, B, C, H, G, F and A on the mother board. Ideally the pins should be replaced with tinned copper wire. These are ringed  in the diagrams below.
2. Connect a capacitor min 4.7 μ F (C4U70ZA) across the +8.5V and -7.5V rails on the back of the mother board, as shown below.

