

ST20 Mod. V

Résistances

<i>Qté</i>	<i>Nom</i>	<i>Valeur/type d'origine</i>	<i>Remplacé par</i>
2	R1	1M, 1/2W	
2	R2	22K, 1/2W	4K7 1/2W
2	R3	2K2, 1/2W	
2	R4	100R, 1/2W	
2	R5	100K, 1/2W	18K 1W
2	R6	3M3, 1/2W	330K 1W
2	R7	91K, 1/2W	
2	R8	1K, 1/2W	
2	R9	22K, 1W	
2	R10	100K, 1W	
2	R11	3M3, 1/2W	1M 1W
2	R12	1M, 1/2W	
2	R13	1M, 1/2W	
2	R14	270R, 1W	
2	R15	270R, 1W	
2	R16	10K, 1/2W	
2	R17	10K, 1/2W	
2	R18	12K, 1/2W	1K2 1/2W
1	R19	47K, 1/2W	
1	R20	4K7, 1/2W	
1	R21	100R, 3W	T3 LUNDAHL LL1638
2	R22	Ø	1K1 1W
2	R23	Ø	82K 1/2W

Condensateurs

<i>Qté</i>	<i>Nom</i>	<i>Valeur/type d'origine</i>	<i>Remplacé par</i>
2	C1	1nF, 400V	
2	C2	50uF electrolytic, 12v	Ø
2	C3	0.1uF, 350V electrolytic	0,1µF 350V silver in oil
2	C4	0.25uF, 350V electrolytic	0,22µF 630V K40Y-9
2	C5	0.02uF, 350V electrolytic	0,1µF 630V K40Y-9
2	C6	0.25uF, 350V electrolytic	0,22µF 630V K40Y-9
2	C7	50uF electrolytic, 25v	47µF 63V ELNA SILMIC
2	C8	50uF electrolytic, 25v	47µF 63V ELNA SILMIC
2	C9	200pF	2000pF silver mica
1	C10	32uF, 400V CAN1	32µF 400V electrolytic
1	C11	32uF, 400V CAN1	33µF 400V SCR MKP
1	C12	32uF, 400V CAN2	68µF 400V SCR MKP
1	C13	32uF, 400V CAN2	22µF 400V electrolytic
2	C14	Ø	2000pF silver mica

Lampes

<i>Qté</i>	<i>Nom</i>	<i>Type</i>	<i>Remplacé par</i>
1	V1	ECC83 / 12AX7 / B339	6H2Π-EB
2	V2	ECC83 / 12AX7 / B339	6H2Π-EB
2	V3	EL84 / N709 / 6BQ5	6Π14Π-EB
2	V4	EL84 / N709 / 6BQ6	6Π14Π-EB
1	V5	GZ34 / 5AR4	GZ32

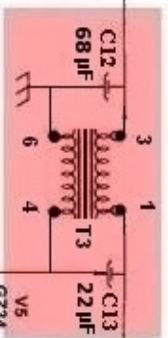
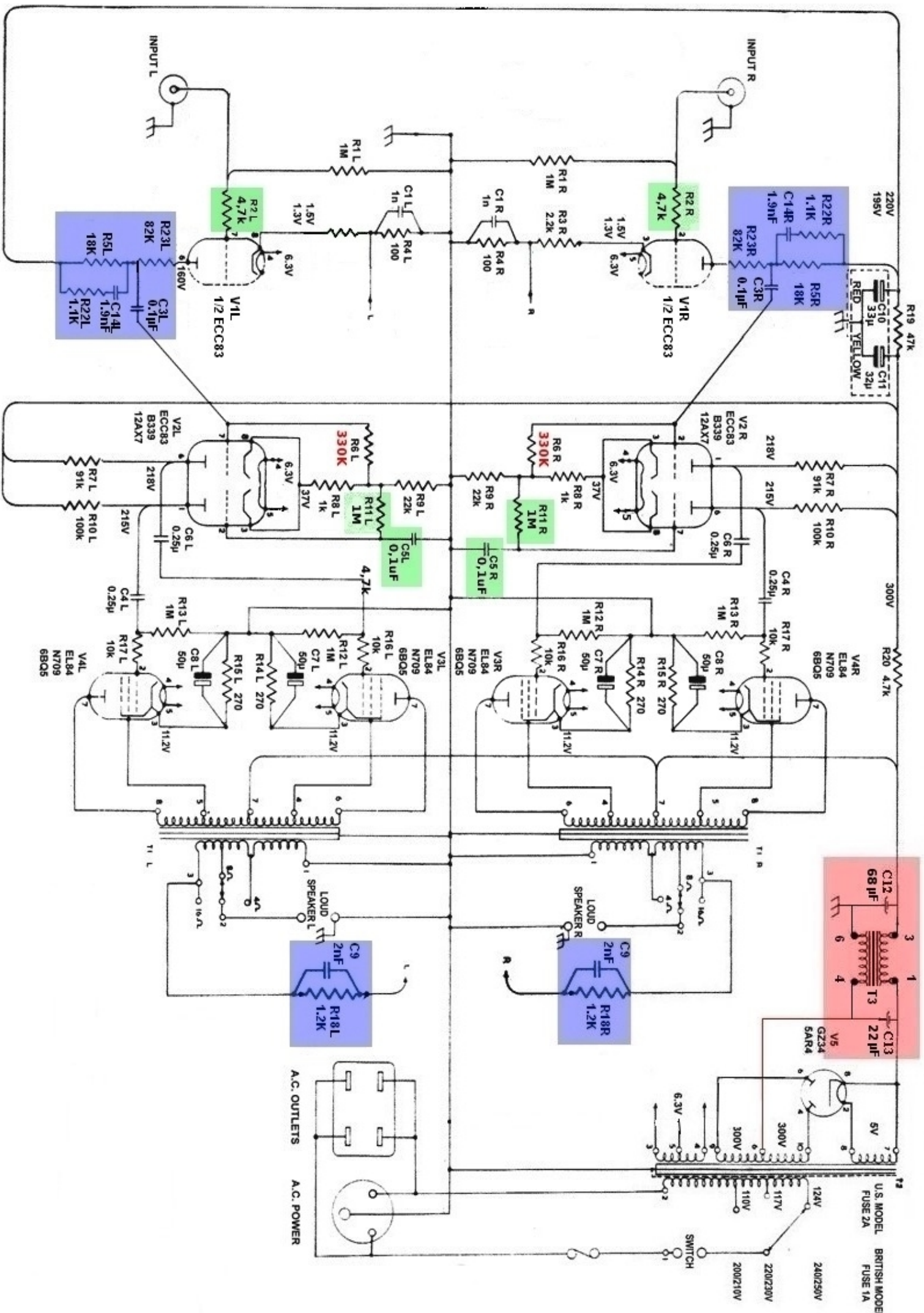

U.S. MODEL
FUSE 2A

BRITISH MODEL
FUSE 1A

