



**PLEASE CHECK FOR CHANGE INFORMATION
AT THE REAR OF THIS MANUAL.**

7A16P PROGRAMMABLE AMPLIFIER

INSTRUCTION MANUAL

Tektronix, Inc.
P.O. Box 500
Beaverton, Oregon 97077
070-2308-00
Product Group 45

Serial Number _____

First Printing MAY 1978
Revised JUL 1983

Copyright © 1978 Tektronix, Inc. All rights reserved.
Contents of this publication may not be reproduced in any
form without the written permission of Tektronix, Inc.

Products of Tektronix, Inc. and its subsidiaries are covered
by U.S. and foreign patents and/or pending patents.

TEKTRONIX, TEK, SCOPE-MOBILE, and  are
registered trademarks of Tektronix, Inc. TELEQUIPMENT
is a registered trademark of Tektronix U.K. Limited.

Printed in U.S.A. Specification and price change privileges
are reserved.

INSTRUMENT SERIAL NUMBERS

Each instrument has a serial number on a panel insert, tag,
or stamped on the chassis. The first number or letter
designates the country of manufacture. The last five digits
of the serial number are assigned sequentially and are
unique to each instrument. Those manufactured in the
United States have six unique digits. The country of
manufacture is identified as follows:

B000000	Tektronix, Inc., Beaverton, Oregon, USA
100000	Tektronix Guernsey, Ltd., Channel Islands
200000	Tektronix United Kingdom, Ltd., London
300000	Sony/Tektronix, Japan
700000	Tektronix Holland, NV, Heerenveen, The Netherlands

TABLE OF CONTENTS

SAFETY SUMMARY	vii
PREFACE	ix
SECTION 1 - INTRODUCTION	
Specifications	1-1
Summary of Programmable Features	1-6
Front-Panel Buttons	1-7
Front-Panel Controls	1-8
Block Diagram	1-10
SECTION 2 - MANUAL OPERATION	
Installation	2-1
Controls, Connectors, and Indicators	2-3
INPUT Connectors	2-3
A-B Switch	2-3
1 Megohm - 50 Ohm Switch	2-3
AC-GND-DC Switches	2-3
POSITION Control	2-4
VARIABLE (CAL IN) Control	2-4
GAIN Adjustment	2-4
BANDWIDTH Switch	2-4
POLARITY Switch	2-4
VOLTS/DIV Switches	2-5
IDENTIFY Switch	2-5
Functional Check	2-5
Preliminary Setup	2-5
Power-up Sequence	2-6
Procedure	2-6
General Operating Information	2-8
Signal Connections	2-8
Vertical Gain Check and Adjustment	2-8
Input Coupling	2-8
VOLTS/DIV and VARIABLE	2-9
POLARITY Switch	2-9
Trace Identification	2-9

7A16P INSTRUCTION

Applications	2-10
General	2-10
Peak-to-Peak Voltage Measurements (AC)	2-10
Instantaneous Voltage Measurements (DC)	2-12
Comparison Measurements	2-14

SECTION 3 - PROGRAMMING

Introduction to the IEEE 488 Bus	3-2
A Typical System	3-2
Types Of Instruments	3-2
Types of Messages	3-3
Maximum Number of Devices	3-4
Maximum Cable Length	3-4
Electrical Specifications	3-4
Bus Signal Lines	3-5
Data Bus	3-5
Transfer Bus	3-5
Management Bus	3-6
Bus Messages	3-8
7A16P Interface Function Subsets	3-10
Source Handshake	3-10
Acceptor Handshake	3-10
Talker	3-10
Listener	3-10
Service Request	3-11
Remote/Local	3-11
Parallel Poll	3-11
Device Clear	3-11
Device Trigger	3-11
Controller	3-11
Addressing the 7A16P	3-12
Addressing Schemes	3-12
Primary Addressing	3-12
Secondary Addressing	3-12
Determining Device Addresses	3-14

7A16P INSTRUCTION

High-Level Messages	3-15
Explanation of Command Syntax	3-16
Set Commands	3-16
Query Commands	3-17
Messages	3-20
Messages with Multiple Sets	3-20
Messages with Multiple Queries	3-21
The SET? Query	3-22
Messages with Sets and Queries	3-22
Query Responses	3-23
Low-Level Messages	3-24
Set Messages	3-25
Query Messages	3-29
Transmitting Messages	3-32
Transmitting Set Messages	3-32
Transmitting Query Messages	3-36
Serial-Poll Responses	3-40
Power on	3-40
Command error	3-40
Execution error	3-41
Busy	3-41

WARNING

The remaining portion of this table of contents lists the Servicing instructions. These Servicing instructions are for use by qualified personnel only. To avoid electrical shock, do not perform any servicing other than that called out in the Operating instructions unless qualified to do so.

SECTION 4 - MAINTENANCE

Preventive Maintenance	4-1
Cleaning	4-1
Exterior	4-2
Interior	4-2
Visual Inspection	4-2
Lubrication	4-2
Troubleshooting	4-2
Troubleshooting Aids	4-3
Schematic Diagrams	4-3

7A16P INSTRUCTION

Circuit-Board Illustrations	4-3
Component-Locator Grids	4-3
Component and Wiring Color Code	4-3
Semiconductor Lead Configurations	4-3
Multi-Pin Connector Identification	4-3
Rear Interface Connector Pin Locations	4-3
Troubleshooting Equipment	4-5
Semiconductor Tester	4-5
Multimeter	4-5
Test Oscilloscope	4-6
Plug-in Extender	4-6
Troubleshooting Procedure	4-7
Check Control Settings	4-7
Check Associated Equipment	4-7
Visual Check	4-7
Check Instrument Performance	4-7
Check Voltages	4-7
Trace the Signal	4-7
Check Individual Components	4-8
Repair and Readjust the Circuit	4-9
Specific Troubleshooting Info.	4-10
Microprocessor System	4-10
Self Test Addresses	4-11
Corrective Maintenance	4-13
Obtaining Replacement Parts	4-13
Standard Parts	4-13
Ordering Parts	4-13
Soldering Techniques	4-14
Attenuator Circuit Board	4-14
Circuit Boards (except Attenuator Board)	4-15
Metal Terminals	4-15
Component Replacement	4-16
Semiconductor Replacement	4-16
Front-Panel LED's	4-16
Free-Standing Components	4-16

7A16P INSTRUCTION

Circuit Board Removal	4-17
Removal of LED and SWITCH Boards	4-18
Removal of ATTENUATOR and ACTUATOR Boards	4-18
Removal of AMPLIFIER, SHIELD, and PROGRAMMING-LOGIC Boards	4-19
Recalibration After Repair	4-20
Repackaging for Shipment	4-20

SECTION 5 - CIRCUIT DESCRIPTION

Introduction	5-1
Block Diagram	5-1
Attenuator	5-3
Input and Coupling Circuit	5-3
X10 Attenuators	5-3
Buffer Amplifier	5-5
Low Impedance Attenuator	5-5
Amplifier	5-6
Polarity Amplifier	5-6
2X Gain Amplifier	5-6
Gain Amplifier	5-7
Positioning Circuit	5-7
Signal Splitter	5-8
Microprocessor System	5-9
MPU and Memory	5-9
PIA's	5-9
Power-up Circuit	5-10
Clock Circuit	5-11
Front Panel Buttons	5-12
Switching Logic	5-12
GPIB Interface	5-13
IEEE 488 Data Bus	5-14
Acceptor Handshake	5-14
Source Handshake	5-14
Readout Circuit	5-15
Basic Readout Operation	5-15
Summing the Time Slots	5-16
Selecting Row and Column Currents	5-17
Encoding a Time-Slot	5-18
MPU Control Example	5-18

SECTION 6 - CALIBRATION

Introduction	6-1
Tektronix Field Service	6-1
Performance Check	6-1
Calibration	6-1
Test Equipment Required	6-2
General	6-2
Calibration Equipment Alternatives	6-2
Checking Programmable Features	6-2
Performance Check Procedure	6-5
Checking Front Panel Functions and Readout	6-5
Checking Balance	6-6
Checking Gain	6-6
Checking Rise Time	6-6
Checking Bandwidth	6-7
Calibration Procedure	6-8
Preliminary Procedure for Calibration	6-8
Check/Adjust MPU Clock Speed	6-9
Check/Adjust DC Balance	6-10
Adjust Low Frequency Gain	6-12
Check/Adjust Gain	6-13
Adjust Positioning	6-15
Adjust Input Compensation	6-16
Adjust Attenuator Compensation	6-17
Adjust Low Frequency Compensation	6-18
Adjust High Frequency Compensation	6-18
Check Bandwidth	6-19

SECTION 7 - ELECTRICAL PARTS LIST**SECTION 8 - DIAGRAMS AND CIRCUIT BOARD ILLUSTRATIONS****SECTION 9 - MECHANICAL PARTS LIST**

SAFETY SUMMARY

This manual contains safety information which the user must follow to ensure safe operation of this instrument. WARNING information is intended to protect the operator; CAUTION information is intended to protect the instrument. The following are general safety precautions that must be observed during all phases of operation and maintenance.

WARNING

Ground the Instrument

To reduce electrical-shock hazard, the mainframe (oscilloscope) chassis must be properly grounded. Refer to the mainframe manual for grounding information.

Do Not Operate in Explosive Atmosphere

Do not operate this instrument in an area where flammable gases or fumes are present. Such operation could cause an explosion.

Avoid Live Circuits

Electrical-shock hazards are present in this instrument. The protective instrument covers must not be removed by operating personnel. Component replacement and internal adjustments must be referred to qualified service personnel.

Do Not Service or Adjust Alone

Do not service or make internal adjustments to this instrument unless another person, capable of giving first aid and resuscitation, is present.

WARNING

Warning Statements

Warning statements accompany potentially dangerous procedures in this manual. The following warnings appear in this manual and are listed here for additional emphasis.

To avoid electrical shock, disconnect the instrument from the power source before soldering.

To avoid electrical shock, disconnect the instrument from the power source before replacing components.

7A16P INSTRUCTION

PREFACE

This manual contains two main divisions: operation and service. These divisions are separated by a heavy divider page. Information following this divider sheet is intended for qualified service personnel only.

The first division (operator's portion) begins with an introductory section that briefly describes the 7A16P Programmable Amplifier. Specifications and programmable features of the plug-in are also listed. Section 2 describes each of the front-panel controls and connectors, and gives complete instructions for manual operation of the plug-in. Measuring techniques and applications are also discussed in Section 2. The last section of the operator's portion describes programmable operation of the 7A16P via the IEEE 488 Interface Bus, also known as the General Purpose Interface Bus (GPIB).* A complete list of device mnemonics is provided in this section.

The second division of the manual (service portion) begins with a section on preventive and corrective maintenance. Included in this section are some general troubleshooting procedures. Section 5 then provides a detailed circuit description of both the analog and digital portions of the 7A16P. Section 6 is a calibration procedure; it lists the equipment needed, and the steps required for calibrating the instrument within specified limits. The remaining three sections provide electrical parts lists, schematic diagrams, and mechanical parts lists.

At the back of the manual is a removable sheet which serves as a pocket programming aid. It lists all of the high-level mnemonic codes and low-level hexadecimal codes for exercising programmable control of the 7A16P Programmable Amplifier.

*Detailed information on the IEEE 488 Bus is provided in IEEE Standard 488-1975, published by the Institute of Electrical & Electronics Engineers -- 345 E. 47 Street, New York, NY 10017.

7A16P INSTRUCTION

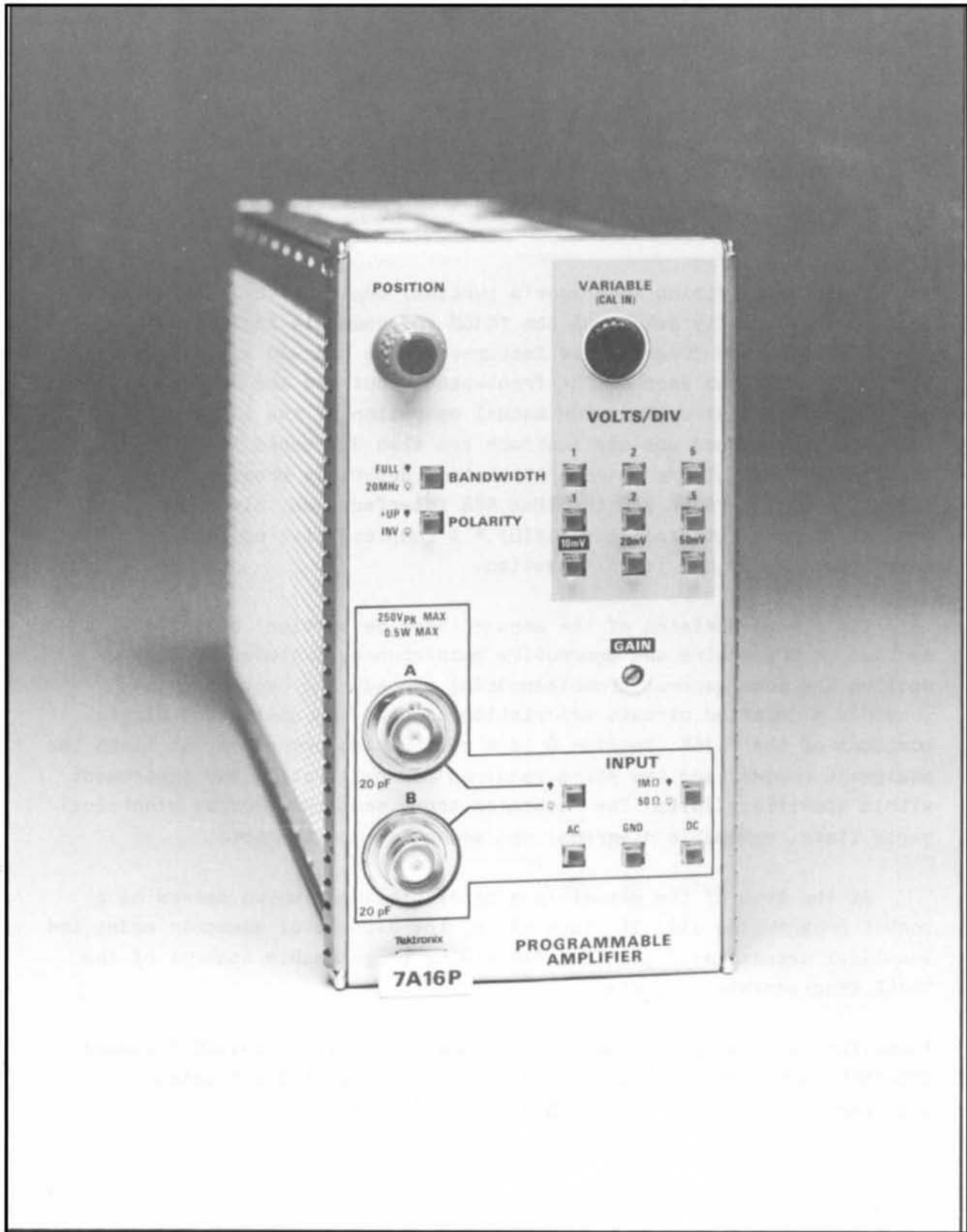

The 7A16P Programmable Amplifier

2308-13

SECTION 1

INTRODUCTION

The TEKTRONIX 7A16P Programmable Amplifier is a wide-bandwidth plug-in amplifier designed for use in TEKTRONIX 7000-Series programmable mainframes. The 7A16P may be inserted in any 7000-Series mainframe without damage, but is recommended for use only in a programmable mainframe.

The 7A16P has calibrated deflection factors ranging from 10 millivolts/division to 5 volts/division. Variable, but uncalibrated, deflection factors are also provided by using the VARIABLE control. The amplifier input can be switched between two input connectors to aid in automatic calibration of the plug-in. Either a 50-ohm or 1-Megohm amplifier input impedance can be selected. AC or DC coupling of the input signal can be selected or the amplifier input grounded to establish a zero-reference level.

The 7A16P has readout encoding and trace identify functions. Thus, vertical scale factors can be displayed on a programmable mainframe having readout display capability.

All functions of the 7A16P can be remotely programmed with the exception of the VARIABLE and GAIN controls and the probe IDENTIFY switch. The status of each programmable function can be set or read by commands sent over the IEEE 488 bus. These commands can be sent in either a high-level or low-level language, both of which are decoded by a microprocessor in the 7A16P.

Specifications

The following tables describe the electrical, programming, environmental, and physical specifications of the 7A16P. Characteristics whose specifications are checked in the calibration procedure are listed under a column entitled PERFORMANCE REQUIREMENTS. Specifications for all other characteristics are listed under SUPPLEMENTAL INFORMATION. Information in the SUPPLEMENTAL INFORMATION column is of a general nature and should not be considered as performance requirements. In cases where a particular plug-in specification is mainframe-dependent, a note has been included referencing the manual for the mainframe.

7A 16P INSTRUCTION

TABLE 1-1
ELECTRICAL SPECIFICATIONS

CHARACTERISTICS	PERFORMANCE REQUIREMENTS	SUPPLEMENTAL INFORMATION
Deflection Factor		
Calibrated Range	10 mV/div to 5 V/div, 9 steps in a 1-2-5 sequence.	
Gain-Ratio Accuracy	+ 2% of indicated deflection factor with GAIN adjusted at 10 mV/div.	
Uncalibrated (VARIABLE)		Continuously variable between calibrated steps; extends deflection factor to at least 12.5 V/div. Expands deflection factor selected to at least 2.5 times calibrated value.
Frequency Response		
Bandwidth	50 ohm input - 200 MHz in 7900-Series programmable mainframe. 1 Megohm input - 150 MHz in 7900-Series programmable mainframe.	
AC Coupled Lower Bandwidth Limit		10 Hz or less.
Limited Bandwidth		20 MHz, + 3 MHz.
Step Response		
Risetime	50 ohm input - ≤ 1.8 nanoseconds in 7900-Series programmable mainframe.	
Limited-Bandwidth Risetime		21 nanoseconds maximum.

7A16P INSTRUCTION

TABLE 1-1 (cont.)

CHARACTERISTICS	PERFORMANCE REQUIREMENTS	SUPPLEMENTAL INFORMATION
Maximum Input Voltage		
1 Megohm		
DC Coupled		250 V (DC + peak AC); AC component 500 V P-P maximum, 1 kHz or less.
AC Coupled		500 V (DC + peak AC); AC component 500 V P-P maximum, 1 kHz or less.
50 ohms		0.5 watts maximum.
Input R and C		
1 Megohm		
Resistance		1 Megohm \pm 2%.
Capacitance		Approx. 20 picofarads.
50 ohm		
DC Resistance		50 ohms \pm 1 ohm.
VSWR		1.5:1 or less up to 200 MHz.
Baseline Shift		
VARIABLE		0.5 division or less when turned through entire range.

7A16P INSTRUCTION

TABLE 1-1 (cont.)

CHARACTERISTICS	PERFORMANCE REQUIREMENTS	SUPPLEMENTAL INFORMATION
Baseline Shift (cont.)		
VOLTS/DIV		0.5 division or less when switched between 10 mV/div and 20 mV/div.
POLARITY		0.5 division or less when switched between +UP and INV.
BANDWIDTH		0.5 division or less when switched between FULL and 20 MHz.
IDENTIFY		Deflects trace +0.2 to +0.4 divisions.
POSITION		
Front Panel Control		At least +10 divisions to at least -10 divisions from graticule center.
Remote Control		From +10.24 to -10.22 divisions in 0.02 division steps.
Displayed Noise (measured tangentially)		10 mV/div: 0.1 divisions or less at FULL bandwidth; 0.02 divisions or less at limited bandwidth.

TABLE 1-1 (cont.)

CHARACTERISTICS	PERFORMANCE REQUIREMENTS	SUPPLEMENTAL INFORMATION
Overdrive Recovery Time (tested at 25°C)		100 microseconds or less to recover to within 1 division of baseline after removal of overdrive signal. Overdrive occurs when the following peak amplitudes are exceeded: 4.0V (on 10-50 mV range) 40V (on 100-500 mV range) 70V (on 1-5 V range)
Crosstalk (unused input to selected input)		2% or less up to 200 MHz.
Feedthrough (ground functions selected)		2% or less up to 200 MHz.

TABLE 1-2

PROGRAMMING SPECIFICATIONS

CHARACTERISTICS	PERFORMANCE REQUIREMENTS	SUPPLEMENTAL INFORMATION
Set-up Time (Full front panel)		Front-panel set-up time is: (decode time)+(byte count)x (time/byte)+(overhead).
High-level		Decode time \approx 11.0 ms Byte count \approx 60 Overhead \approx 0.4 ms
Low-level		Decode time \approx 1.0 ms Byte count = 10 Overhead \approx 0.1 ms

TABLE 1-3

ENVIRONMENTAL SPECIFICATIONS

For temperature, altitude, vibration, shock, and humidity specifications, refer to the manual for the associated mainframe.

TABLE 1-4

PHYSICAL SPECIFICATIONS

Weight	1.2 Kg. (2.6 lbs.)
Dimensions	Fits 7000-Series mainframe plug-in compartment.

Summary of Programmable Features

The TEKTRONIX 7A16P Programmable Amplifier can be operated in either Local or Remote mode. In Local mode, it operates like a non-programmable plug-in, such as the TEKTRONIX 7A16A. That is, its functions are controllable only from the front panel.

When the 7A16P is set to Remote mode, however, the front panel is rendered inoperative except for three non-programmable functions: VARIABLE, GAIN, and IDENTIFY. Under remote control, functions can be controlled only by commands sent over the IEEE 488 bus. However, as control settings are effected remotely, the front-panel lights will indicate accordingly.

The Remote/Local state of the 7A16P is slaved to the Remote/Local state of the mainframe in which it is installed. Thus the mainframe must be set to Remote mode for programmed control of the plug-in, and must be set to Local mode for front-panel control of the plug-in.

Front-Panel Buttons

Each pushbutton on the 7A16P front panel serves as both a switch and an indicator. A Light Emitting Diode (LED) mounted behind each button indicates the present state of the function controlled by that button, regardless of whether the corresponding function was set manually or under program control. The switches themselves are a momentary-contact type; it is only necessary to tap a particular button to set that function.

The operation of the front-panel buttons generally falls into one of two categories. The first category includes the VOLTS/DIV and AC-GND-DC functions. Since there are more than two switch settings for each of these functions, pushbuttons in this category are part of a ganged-switch arrangement. Pressing a particular button cancels the setting of the previously pressed button and selects the new setting. For example, if GND has been pressed or remotely set as indicated by the lighting of the GND button, pressing the AC button will extinguish the GND light and switch the input coupling to AC; the AC button will then be lit to indicate the new setting.

The second category of buttons includes the following functions:

- BANDWIDTH (Full or 20 MHz)
- POLARITY (+Up or Invert)
- INPUT Connector (A or B)
- INPUT Impedance (1 Megohm or 50 ohms)

Since there are just two settings for each of the above functions, buttons in this category are essentially toggle switches, and the lighting of each button indicates the current state of the function controlled by that button. For example, repeatedly pressing the POLARITY button alternately illuminates and extinguishes the POLARITY button. When POLARITY is lit, inverted polarity is selected; when POLARITY is not lit, normal polarity is selected.

Front-Panel Controls

There are three 7A16P front-panel rotary controls: POSITION, VARIABLE, and GAIN. Only the POSITION control is fully programmable. When the 7A16P is in Local mode, the POSITION control operates just like that of a non-programmable plug-in. That is, the vertical position of the trace is controlled by the current position of the knob. When the 7A16P is set to Remote mode, the POSITION control is disabled and the trace position is determined by commands which set a 10-bit Digital-to-Analog Converter (DAC). Since the POSITION control is disabled during Remote operation, its current knob setting may not indicate the true trace position. However, when the 7A16P is again set to Local mode, the vertical position of the trace reverts back to the position indicated by the POSITION control. During Remote operation, the trace position can be read as well as set over the IEEE 488 bus.

The VARIABLE control allows the vertical scale factors to be increased to about 2.5 times their calibrated value (e.g., on 5 Volts/Div the scale factor can be increased to about 12.5 Volts/Div). In Local mode, the VARIABLE control can be continuously varied over its entire range and is operative only when in the extended (unlatched) position. In Remote mode, the setting of the VARIABLE control can not be read or set. However, the VARIABLE control can be enabled or disabled under remote control, regardless of whether the control is in the extended or unextended position. When changing from Local to Remote mode, the VARIABLE control is automatically set to OFF so that the vertical scale factors are calibrated.

The GAIN adjustment is a front-panel screwdriver adjustment that can vary the amplifier gain over a narrow range to allow for differences in gain between mainframes. It is disabled when VARIABLE is selected.

The probe IDENTIFY switch adds an offset to the displayed trace to help the operator locate the trace in a multi-trace display. This switch is available only at the probe tip and can not be set under remote control. The switch setting can, however, be read under remote control.

Table 1-5 provides a list of all the 7A16P functions and indicates which functions can be set or read (queried) under manual and remote operation. Setting a function manually refers to pressing a given button or turning a control; reading a function manually refers to looking at

7A16P INSTRUCTION

the illumination of a particular button or noting the position of a control. Setting and reading functions under remote control refers to setting a function or interrogating the status of a function by sending or receiving messages over the IEEE 488 bus. Information on how this is done is contained in Section 3.

For more information on each of the functions and how they are used, refer to Section 2.

TABLE 1-5

LIST OF 7A16P FUNCTIONS

FUNCTION	MANUAL OPERATION		REMOTE OPERATION	
	SET	READ	SET	READ
BANDWIDTH (FULL - 20 MHz)	X	X	X	X
POLARITY (+UP - INV)	X	X	X	X
INPUT Connector (A - B)	X	X	X	X
INPUT Impedance (1 Megohm-50 ohms)	X	X	X	X
INPUT Coupling (AC-GND-DC)	X	X	X	X
VOLTS/DIV	X	X	X	X
POSITION Control	X	X	X	X
VARIABLE Control ¹	X			
GAIN Adjustment ²	X			
Probe Attenuation				X
Plug-in Type ³		X		X

NOTE

An "X" in the above chart denotes that a particular function can be set or read.

¹ The setting of the VARIABLE control is not programmable, but the control can be enabled or disabled in Remote mode.

² The GAIN adjustment is disabled if the VARIABLE control is enabled.

³ The plug-in type (7A16P) is inscribed on the front panel and can be read under program control with the ID command.

7A16P INSTRUCTION

Block Diagram

The following is a simplified block diagram of the 7A16P (Fig. 1-1) and a brief description of the blocks. It is included here to provide background information for the sections that follow.

The input signal is applied to the attenuator through one of the INPUT BNC connectors on the front panel. Precision attenuators are switched into the signal path to select the desired attenuation (VOLTS/DIV) factor. The amplifier selects normal or inverted signal polarity and provides a 1X or 2X attenuation. The positioning circuit adds a DC component to the signal for positioning. A final amplifier stage splits the signal into separate display and trigger signals of equal amplitude.

The 7A16P attenuator, front panel, and IEEE 488 interface are controlled by a microprocessor system in the plug-in. The heart of this system is a Motorola M6800 Microprocessing Unit (MPU). A control program, resident in 4K (1K=1024) bytes of Read Only Memory (ROM), directs the MPU activity. The MPU uses Random Access Memory (RAM) as a "scratch pad".

Three Peripheral Interface Adapters (PIA's) handle internal communication between the MPU and the other circuits in the plug-in. The switching logic drives the attenuator and front panel. The IEEE 488 interface handles the handshaking on the bus.

The clock circuit generates the two-phase clock signal required by the MPU. When power-up occurs, the power-up circuit initializes the MPU and PIA's and starts the clock circuit. The readout circuit encodes the attenuator settings and sends the readout information to the mainframe.

A detailed circuit description of these blocks is included in Section 5.

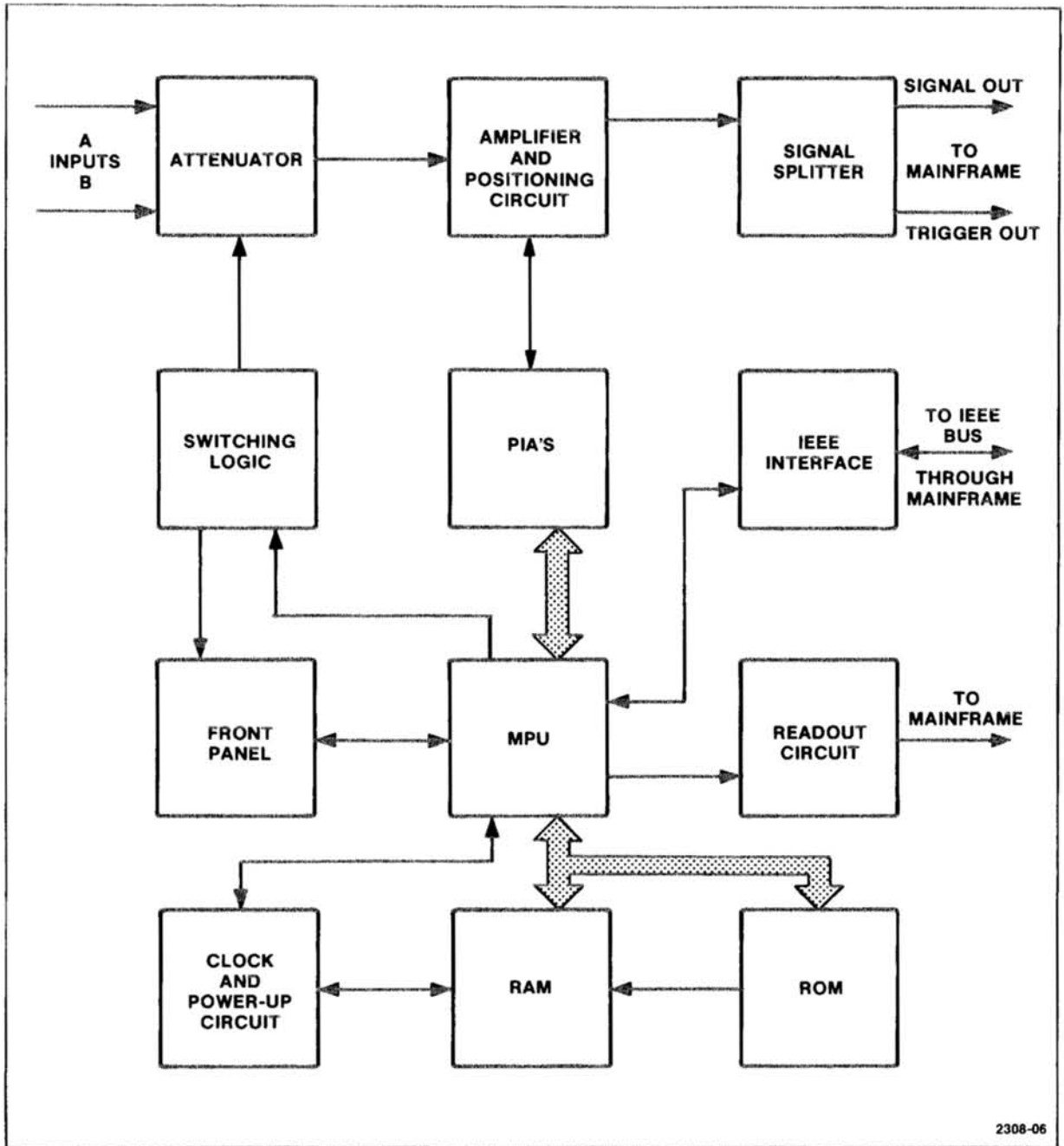

Fig. 1-1. Block diagram of the 7A16P.

SECTION 2

MANUAL OPERATION

This section contains a description of the 7A16P controls and connectors, and includes instructions for manual (non-programmable) operation of the plug-in. This is followed by a "functional check" section, which provides a quick verification of instrument performance. Also included are instructions for installing the plug-in, general information on signal input connections, and other subjects that pertain to various measurement applications.

Installation

The 7A16P is calibrated and ready for use as received. It may be installed in any compartment of a TEKTRONIX 7000-Series Oscilloscope without damage, but is recommended for use only in 7000-Series programmable mainframes. It is primarily intended for use in vertical plug-in compartments.

CAUTION

Always turn off the mainframe power before installing or removing plug-ins to prevent damage to the circuitry.

To install the plug-in, align the upper and lower rails of the 7A16P with the mainframe tracks and insert the plug-in. The front panel will be flush with the front of the mainframe when the plug-in is fully inserted, and the latch at the bottom left corner will be in place against the front panel.

To remove the 7A16P, pull on the latch (inscribed with the unit identification "7A16P") and the plug-in will unlatch. Continue pulling on the latch to slide the 7A16P out of the mainframe.

7A16P INSTRUCTION

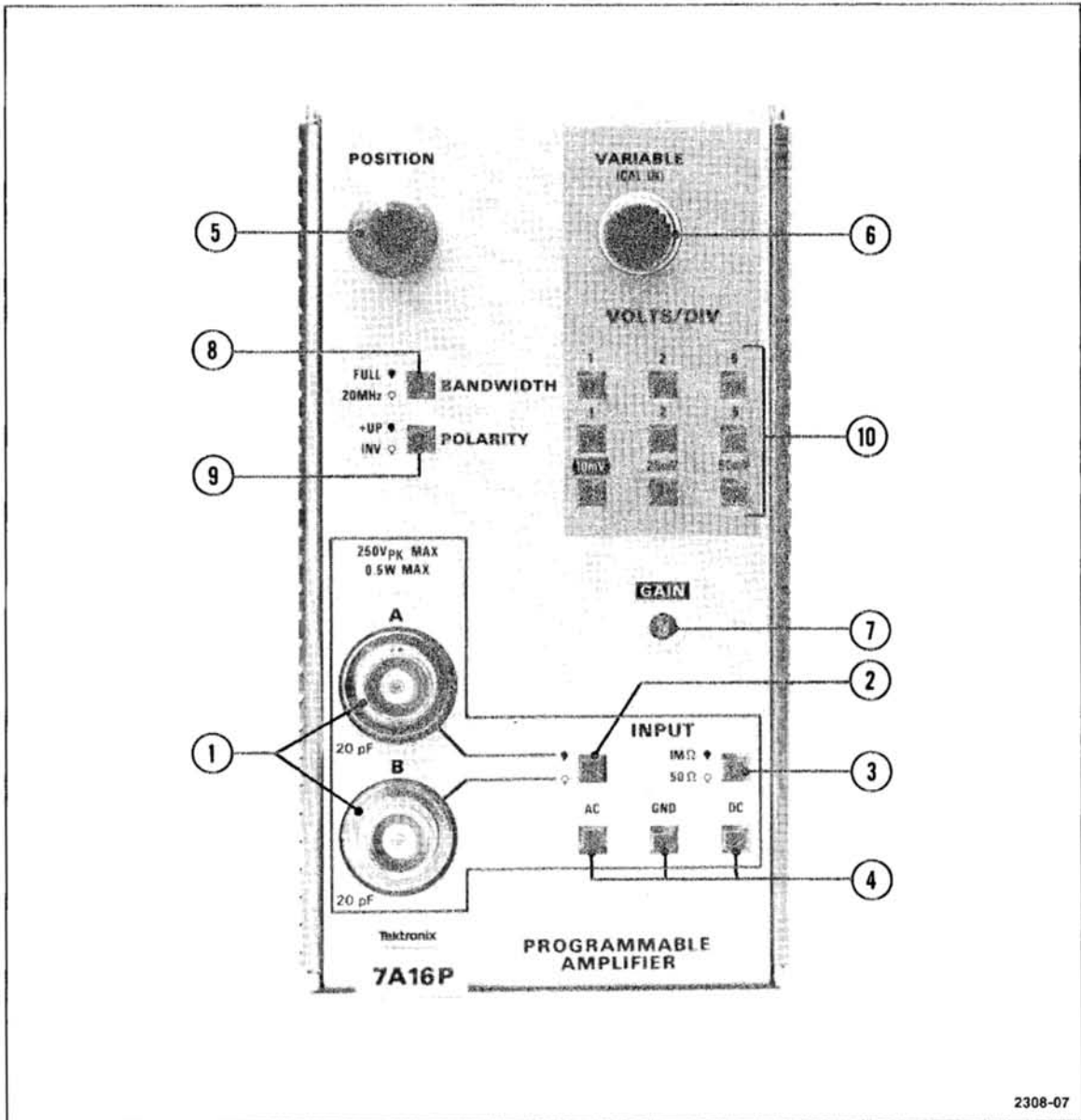

2308-07

Fig. 2-1. Front panel of the 7A16P.

Controls, Connectors, and Indicators**① INPUT Connectors**

Two BNC input connectors are provided to aid in switching between two inputs (a signal source and a calibration source, for example). Either the A or B input is selected by a lighted pushbutton switch adjacent to the connectors.

② A-B Switch

Selects either the A or B input connector. When lit, it selects the B input; when unlit, it selects the A input.

③ 1 Megohm - 50 Ohm Switch

Selects an amplifier input impedance of either 1 Megohm or 50 ohms. When lit, it selects 50 ohms; when unlit it selects 1 Megohm.

④ AC-GND-DC Switches

These three switches select one of the following input coupling modes depending on which of the three buttons was last pressed:

AC: The AC component of the signal is coupled to the input while the DC component is blocked.

GND: The input connectors are disconnected from the amplifier input.

DC: Both the AC and DC components of the signal are coupled to the amplifier input.

(The button that is currently lit indicates the selected input coupling mode.)

⑤ POSITION Control

Controls the vertical position of the trace by injecting a DC offset current into the amplifier along with the input signal.

⑥ VARIABLE (CAL IN) Control

Provides continuously variable deflection factors between calibrated steps. The variable deflection factors overlap and are uncalibrated. When the 7A16P is set to Local mode, this control is operative only when in the extended position. When the 7A16P is set to Remote mode, it is inoperative whether in its extended position or not unless enabled under program control. Its control setting is not programmable. When changing from Local to Remote mode, the VARIABLE control is automatically set to OFF so that the vertical scale factors are calibrated.

⑦ GAIN Adjustment

A front-panel screwdriver adjustment that can vary the amplifier gain over a narrow range to allow for differences in gain between mainframes. It is disabled when VARIABLE is selected, but can not be disabled under program control (unless VARIABLE is selected).

⑧ BANDWIDTH Switch

Selects full amplifier bandwidth or reduced amplifier bandwidth of 20 Megahertz. When lit, reduced bandwidth is selected; when unlit, full bandwidth is selected.

⑨ POLARITY Switch

Selects inverted or normal amplifier mode. When lit, inverted mode is selected; when unlit, normal mode is selected.

⑩ VOLTS/DIV Switches

These nine switches select calibrated deflection factors from 10 millivolts/division to 5 volts/division in nine steps with a 1-2-5 sequence. The last button pressed determines the current setting. (The button that is currently lit indicates the selected deflection factor.)

IDENTIFY Switch

Adds an offset (0.3 divisions as viewed on a CRT display) to help the operator identify the trace in a multi-trace display. Scale factor readout is replaced with the word IDENTIFY. The IDENTIFY switch is available only at the probe tip. It is non-programmable but can be disabled (no trace shift) under program control.

Functional Check

The following procedure demonstrates the use of the connectors and controls of the 7A16P, while at the same time providing a means of checking the basic operation of the instrument. Refer to the description of the controls, connectors, and indicators while performing this procedure. If performing the functional check procedure reveals a malfunction or possible improper adjustment, first check the operation of the associated mainframe. If the mainframe seems to be working properly, have the 7A16P examined by a qualified service technician.

Preliminary Setup

With the mainframe power off, install the 7A16P into the vertical plug-in compartment of a 7000-Series programmable mainframe. Install a 7B-Series time-base unit (if applicable) into the horizontal plug-in compartment.

With the mainframe power on, set the mainframe trigger-source switch (if applicable) to select the appropriate vertical compartment. Set the time-base unit to a sweep speed of 500 microseconds/div and set the triggering mode to PP AUTO. Also, adjust the mainframe beam intensity, if necessary.

7A16P INSTRUCTION

Power-up Sequence

When the mainframe is turned on, the 7A16P is set to a predetermined state as indicated by the lighted front-panel buttons. The status of the front-panel buttons should indicate the following:

BANDWIDTH:	FULL
POLARITY:	+UP
VOLTS/DIV:	5
INPUT CONNECTOR:	A
INPUT IMPEDANCE:	1 Megohm
INPUT COUPLING:	DC

Also, the trace is moved to the position indicated by the POSITION control.

Procedure

NORMAL OPERATION

- 1) After an adequate warm-up period (20 minutes or more), set the 7A16P AC-GND-DC switches to GND, and adjust the POSITION control so that the trace is vertically centered on the CRT graticule.
- 2) Connect a 0.4 volt, 1 kilohertz square wave to input connector A. (Input connector A is automatically selected during the power-up sequence.)
- 3) Set the 7A16P VOLTS/DIV switches to 100 mV/div (or 10 mV/div if a 10X probe is being used). The VARIABLE control should be pressed in to the calibrated position.
- 4) Set the AC-GND-DC switches for DC coupling.
- 5) With the time-base set to a sweep speed of 500 microseconds/div, adjust the LEVEL control for a stable display when PP AUTO triggering mode is selected.
- 6) Check for a four-division amplitude of the calibration signal. (The GAIN adjustment on the 7A16P can be used to achieve the proper

deflection of the calibration signal.)

INVERTED POLARITY

7) Press the POLARITY button. The POLARITY button should illuminate and the display should be inverted. The CRT readout will display an inverted arrow (\downarrow) or minus sign (-) to indicate the inverted display.

AC COUPLING

8) Set the AC-GND-DC switches to AC. Check that the AC button is lit and that the trace is now centered on the display graticule.

BANDWIDTH LIMIT

9) Press the BANDWIDTH button. Check that the button is lit, indicating limited bandwidth. NOTE: At higher frequencies, the corners of a square wave are rounded (the high frequency components of the square wave are filtered out).

VARIABLE GAIN

10) Unlatch the VARIABLE (VOLTS/DIV) control to the extended, or uncalibrated, position. Notice that the size of the displayed signal decreases as the VARIABLE control is turned counterclockwise. The CRT readout will display an angle bracket (>) to indicate the uncalibrated display. Push in the VARIABLE control to restore the calibrated display.

B CONNECTOR

11) Press the B INPUT connector button and note that it illuminates. No signal should now appear on the display at the center of the graticule. Reconnect the calibration signal to the B INPUT connector and check that the signal again appears on the display.

INPUT IMPEDANCE

12) Press the 1-Megohm/50-ohm switch. Check that the button is lit, indicating 50-ohm input impedance. NOTE: If a signal generator with 50-ohm output impedance is being used, the displayed signal amplitude will decrease by one-half when this button is pressed.

General Operating Information

Signal Connections

When a 10X or 100X probe with a readout-coding ring is present on the selected input connector, the CRT readout (Volts/Div) will indicate the actual deflection factor at the probe tip; thus it will not be necessary to multiply the CRT readout by the probe attenuation factor. However, use of a probe with the 7A16P is not always advisable, since the amplifier input is optimized for 50 ohms and use of a probe may cause the amplifier step response to have aberrations that are out of specification.

Vertical Gain Check and Adjustment

To check the gain of the 7A16P, select a VOLTS/DIV setting of 10 mV and connect a 40 mV, 1 kHz square wave to the input connector. The vertical deflection should be exactly four divisions if a 1X probe or no probe is being used. If necessary, adjust the front-panel GAIN for exactly four divisions.

Input Coupling

The AC-GND-DC switches allow a choice of input coupling methods. The type of display desired and the applied signal will determine the method of coupling to use.

The DC coupling mode can be used for most applications. For AC signals with frequencies below about 30 Hz, and square waves whose low-frequency components are important to the display, it is necessary to use DC coupling to obtain a satisfactory presentation.

In the AC coupling mode, the DC component of the signal is blocked by a capacitor in the input circuit. The AC coupling mode provides the best display of signals with a DC component much larger than the AC component.

7A16P INSTRUCTION

The GND mode open-circuits the 7A16P input connectors and can be used to supply a zero-reference trace.

VOLTS/DIV and VARIABLE

The amount of deflection produced by a signal is determined by the signal amplitude, the attenuation factor of the probe (if used), the settings of the VOLTS/DIV switches, and the setting of the VARIABLE control. Calibrated deflection factors represented by the settings of the VOLTS/DIV switches apply only when the VARIABLE control is in the CAL position (pushed in) or when disabled under program control.

The VARIABLE control provides variable uncalibrated settings between the calibrated settings of the VOLTS/DIV switches. With the VARIABLE control extended and set fully counterclockwise, the uncalibrated deflection factor is extended to at least 2.5 times the attenuator setting. By applying a calibrated voltage source to the INPUT connector, any specific deflection factor can be set within the range of the VARIABLE control.

POLARITY Switch

The POLARITY switch provides a means of inverting the displayed signal. With the POLARITY set to +UP, a positive-going signal at the selected INPUT produces an upward deflection of the CRT display. With the POLARITY set to INVERT, a positive-going signal will produce a downward deflection of the CRT display.

Trace Identification

When the IDENTIFY probe button is pressed, the trace is deflected upward about 0.3 divisions to identify the 7A16P trace. This feature is particularly useful when multiple traces are displayed on the CRT. In mainframes with readout, it also replaces the deflection factor readout with the word "IDENTIFY".

Applications

General

The following information describes the procedures and techniques for making visual measurements with a 7A16P and an associated TEKTRONIX programmable mainframe and time-base. (To some extent, this information is also applicable to measurements made under program control.) These applications are not described in detail, since each application must be adapted to the requirements of the individual measurement. This instrument can also be used for many applications which are not described in this manual. Contact your local TEKTRONIX Field Office or representative for assistance in making specific measurements.

Peak-to-Peak Voltage Measurements (AC)

To make peak-to-peak voltage measurements, use the following procedure:

- 1) Apply the signal to the selected input connector.
- 2) Press the AC coupling switch.

NOTE

For low-frequency signals below about 30 Hertz, use the DC coupling mode to prevent attenuation of the signal.

3) Select a VOLTS/DIV setting that displays about five vertical divisions of the waveform.

4) Set the time-base Triggering controls for a stable display. Set the Time Base to a sweep rate which displays several cycles of the waveform.

5) Adjust the 7A16P POSITION control so the lower portion of the waveform coincides with one of the graticule lines below the center

horizontal line, and the top of the waveform is within the viewing area. With the time-base POSITION control, move the display so one of the upper peaks lies near the center vertical line (see Fig. 2-2).

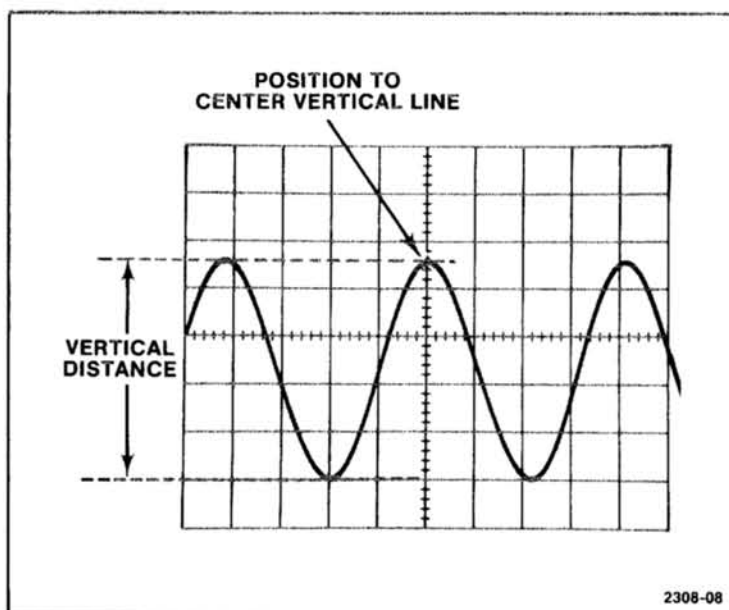

Fig. 2-2. Measuring the peak-to-peak voltage of a waveform.

6) Measure the divisions of vertical deflection peak-to-peak (not including the trace width). Check that the VARIABLE control is in the CAL position.

NOTE

This technique can also be used to make measurements between two points on the waveform, rather than peak-to-peak.

7) Multiply the distance measured in step 6 by the VOLTS/DIV switch setting. Include the attenuation factor of the probe if used. (If the VOLTS/DIV setting is taken from the CRT readout, the attenuation factor is already included -- assuming a coded probe is used.)

7A16P INSTRUCTION

EXAMPLE: Assume that the peak-to-peak vertical deflection is 4.5 divisions using a 10X attenuator probe, and the VOLTS/DIV switch is set to 1 V.

$$\text{Volts} = \begin{array}{c} \text{vertical} \\ \text{deflection} \\ \text{(divisions)} \end{array} \times \begin{array}{c} \text{VOLTS/DIV} \\ \text{setting} \end{array} \times \begin{array}{c} \text{probe} \\ \text{attenuator} \\ \text{factor} \end{array}$$

Substituting the given values:

$$\text{Volts Peak-to-Peak} = 4.5 \times 1 \times 10$$

the peak-to-peak voltage is 45 volts.

If you are using a 7A16P with a coded probe and a mainframe equipped with readout, simply multiply the distance measured in step 6 by the deflection factor displayed on the CRT.

Instantaneous Voltage Measurements (DC)

To measure the DC level at a given point on a waveform, proceed as follows:

- 1) Connect the signal to the selected input connector.
- 2) Select a VOLTS/DIV setting that displays about five divisions.
- 3) With the time base in PP AUTO mode, press the 7A16P GND coupling switch and position the trace to the bottom graticule line or other reference line. If the voltage is negative with respect to ground, position the trace to the top graticule line. Do not move the 7A16P POSITION control after this reference line has been established.
- 4) Press the 7A16P DC coupling switch. The ground reference line can be checked at any time by pressing the GND switch.

NOTE

To measure a voltage level with respect to another (reference) voltage rather than ground, make the following changes to step 4. Press the DC coupling switch and apply the reference voltage to the selected input connector. Then position the trace to the reference line and disconnect the reference voltage. Reconnect the voltage to be measured to the same input connector. (It is also possible to connect the reference voltage to one input connector and the measured voltage to the other input connector. The A/B switch is then used to switch from one signal to the other.)

CAUTION

Do not attempt to "float" the mainframe to make differential measurements. The mainframe must be properly grounded to reduce electrical-shock hazard.

5) Set the time-base Triggering controls for a stable display. Set the time base sweep rate for an optimum display of the waveform.

6) Measure the distance in divisions between the reference line and the point on the waveform at which the DC level is to be measured. For example, in Fig. 2-3, the measurement is between the reference line and point A.

7) Establish the polarity of the waveform. With the POLARITY switch set to +UP (off), any point above the reference line is positive.

8) Multiply the distance measured in step 6 by the VOLTS/DIV switch setting. Include the attenuation factor of the probe, if applicable.

EXAMPLE: Assume the vertical distance measured is 4.6 divisions (see Fig. 2-3) and the waveform is above the reference line using a 10X probe with a VOLTS/DIV switch setting of 0.5 V.

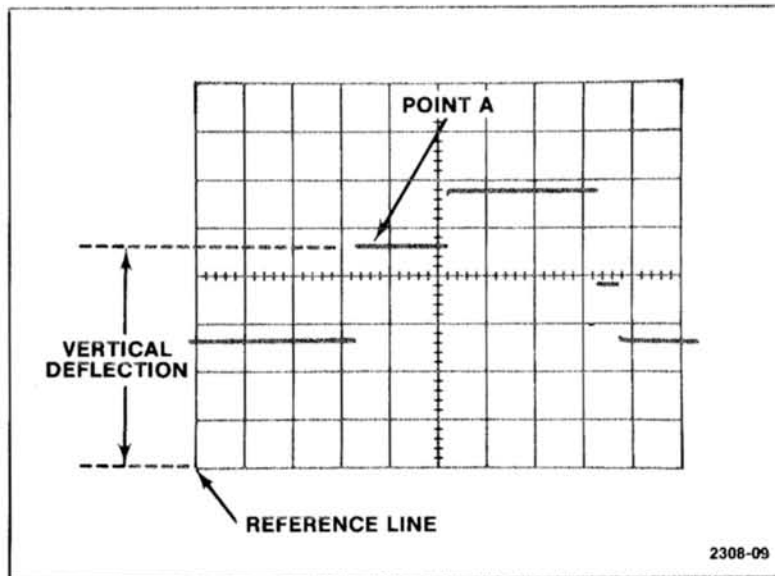

Fig. 2-3. Measuring instantaneous voltage with respect to some reference.

Using the formula:

$$\text{Instantaneous Voltage} = \text{vertical distance (divisions)} \times \text{polarity} \times \text{VOLTS/DIV setting} \times \text{probe attenuation factor}$$

Substituting the given values:

$$\text{Instantaneous Voltage} = 4.6 \times 1 \times 0.5V \times 10$$

the instantaneous voltage is 23 volts.

Comparison Measurements

In some applications it may be desirable to establish units of measurement other than those indicated by the VOLTS/DIV switches. This is particularly useful when comparing unknown signals to a reference amplitude. One use for the comparison-measurement technique is in calibrating equipment, where the desired amplitude does not produce an exact number of divisions of deflection. The adjustment will be easier

7A16P INSTRUCTION

and more accurate if arbitrary units of measurement are established, so that the correct adjustment is indicated by an exact number of divisions of deflection. The following procedure describes how to establish arbitrary units of measure for comparison measurements.

To establish a vertical deflection factor based upon a specific reference amplitude, proceed as follows:

1) Connect the reference signal to the A input connector and select the A input with the A/B input switch. Set the time-base sweep rate to display several cycles of the signal.

2) Set the VOLTS/DIV switches and the VARIABLE control to produce a display which is an exact number of vertical divisions in amplitude. Do not change the VARIABLE control after obtaining the desired deflection.

3) To establish an arbitrary vertical deflection factor that allows the amplitude of an unknown signal to be measured accurately at any VOLTS/DIV setting, the amplitude of the reference signal must be known. If it is not known, it can be measured before the VARIABLE control is set in step 2.

4) Divide the amplitude of the reference signal (volts) by the product of the vertical deflection (divisions) established in step 2 and the setting of the VOLTS/DIV switches.

This is the vertical conversion factor:

$$\text{Vertical Conversion Factor} = \frac{\text{reference signal amplitude (volts)}}{\text{vertical deflection (Divisions)} \times \text{VOLTS/DIV setting}}$$

5) To measure the amplitude of an unknown signal, connect the unknown signal to the B input connector and select the B input with the A/B input switch. Set the VOLTS/DIV switches to a setting that provides sufficient vertical deflection to make an accurate measurement. Do not re-adjust the VARIABLE control.

NOTE

A moderate amount of crosstalk from the signal previously input to connector A may be observed at connector B. As noted in the specifications section, this crosstalk should never exceed 2%. However, if crosstalk is a problem, remove the reference signal from the A connector.

6) Measure the vertical deflection in divisions and calculate the amplitude of the unknown signal using the following formula:

$$\text{Signal Amplitude} = \text{VOLTS/DIV setting} \times \text{vertical conversion factor} \times \text{vertical deflection (divisions)}$$

EXAMPLE: Assume a reference signal amplitude of 30 volts, a VOLTS/DIV setting of 5V, and the VARIABLE control adjusted to provide a vertical deflection of four divisions.

Substituting these values in the vertical conversion factor formula (step 4):

$$\text{Vertical Conversion Factor} = \frac{30\text{V}}{4 \times 5\text{V}} = 1.5$$

Then with a VOLTS/DIV setting of 2V, the peak-to-peak amplitude of an unknown signal which produces a vertical deflection of five divisions can be determined by using the signal amplitude formula (step 6):

$$\text{Signal Amplitude} = 2\text{V} \times 1.5 \times 5 = 15 \text{ volts}$$

SECTION 3

PROGRAMMING

The 7A16P can be operated by remote control over a versatile instrument bus known as the IEEE 488 bus. A detailed description of the bus is given in IEEE Standard 488-1975 as well as ANSI Standard MC 1.1-1975. A brief introduction to the IEEE 488 standard is included in this section as background information.

The 7A16P is interfaced to the IEEE bus through the mainframe in which it is installed. The mainframe provides a transparent interface between the IEEE 488 bus and the internal 7000-Series bus used to program the plug-ins.

The Remote/Local state of the 7A16P is slaved to the Remote/Local state of the programmable mainframe. When the mainframe is set to Remote mode, the 7A16P can be operated by remote control over the IEEE 488 bus. Either the controller-in-charge or other designated talker and listeners can then set or read any of the 7A16P programmable functions. In Remote mode, the front panel is disabled except for the settings of the VARIABLE and GAIN controls and the probe IDENTIFY switch; these are the only non-programmable functions on the 7A16P. The status of the probe IDENTIFY switch can be read, however.

After the 7A16P has been set to Remote state, it can be remotely controlled by messages sent over the bus. This remote programming can be accomplished by either of two types of device-dependent messages: a high-level language (ASCII character strings) or a low-level language (hexadecimal codes). The advantage of the high-level language is that messages can be sent with simple, easy-to-remember mnemonics. Since the plug-in itself decodes these high-level commands, it is not necessary to incorporate this decoding capability into special driver software. The main advantage of using the low-level code is that fewer keystrokes and less bus time is required than when programming with the high-level language. When access time is more important than ease of programming, the low-level language of the 7A16P should be used. Both methods of programming the 7A16P are explained following a brief introduction to the IEEE 488 bus.

Introduction to the IEEE 488 Bus

The IEEE 488 bus is a versatile instrument bus designed to provide an effective communications link for data and instructions. The bus itself is entirely passive. The active components of the interface are contained within each device. Instruments designed to operate according to this universal standard can be connected directly to the bus and operated by a controller with appropriate programming. The instructions and data generated by instruments can be coded in either ASCII or binary. The IEEE standard specifies only the mechanical, electrical, and functional aspects of the interface. The operational, or device dependent, aspects of the system are purposely not specified to allow greater flexibility as to the types of devices that can be interconnected.

A Typical System

The IEEE 488 bus uses eight data lines and eight control lines. Information is transferred bit-parallel, byte-serial by an asynchronous handshake. The handshake signals guarantee that each data byte has been transferred properly before allowing another byte to be transferred across the bus. This allows instruments with different data transfer rates to operate together if they conform to the handshake state diagrams defined in the IEEE 488 standard.

Types of Instruments. Instruments connected to the bus can be classified as either controllers, talkers, or listeners. A controller designates which devices are to talk or listen and exercises other bus management functions; at any given time, there can be only one controller. A talker is a device capable of transmitting data and instructions on the Data lines; there can be only one talker at a time to avoid confusion in message and data transfer. A listener is a device capable of responding to data or instructions received on the Data lines; there can be more than one listener at a time since no confusion results.

A device need not be a talker or listener or controller at all times. It may be idle part of the time. Other devices (such as a digital

multimeter) may alternately function as a talker or listener depending on whether they are listening to instructions or generating data.

A typical system is diagrammed in Fig. 3-1. It includes a controller (such as a TEKTRONIX CP1164 Controller), a talker (such as a counter or digital multimeter), and a listener (such as a line printer or signal generator). Also included is a TEKTRONIX 7912AD Programmable Digitizer which may either talk or listen.

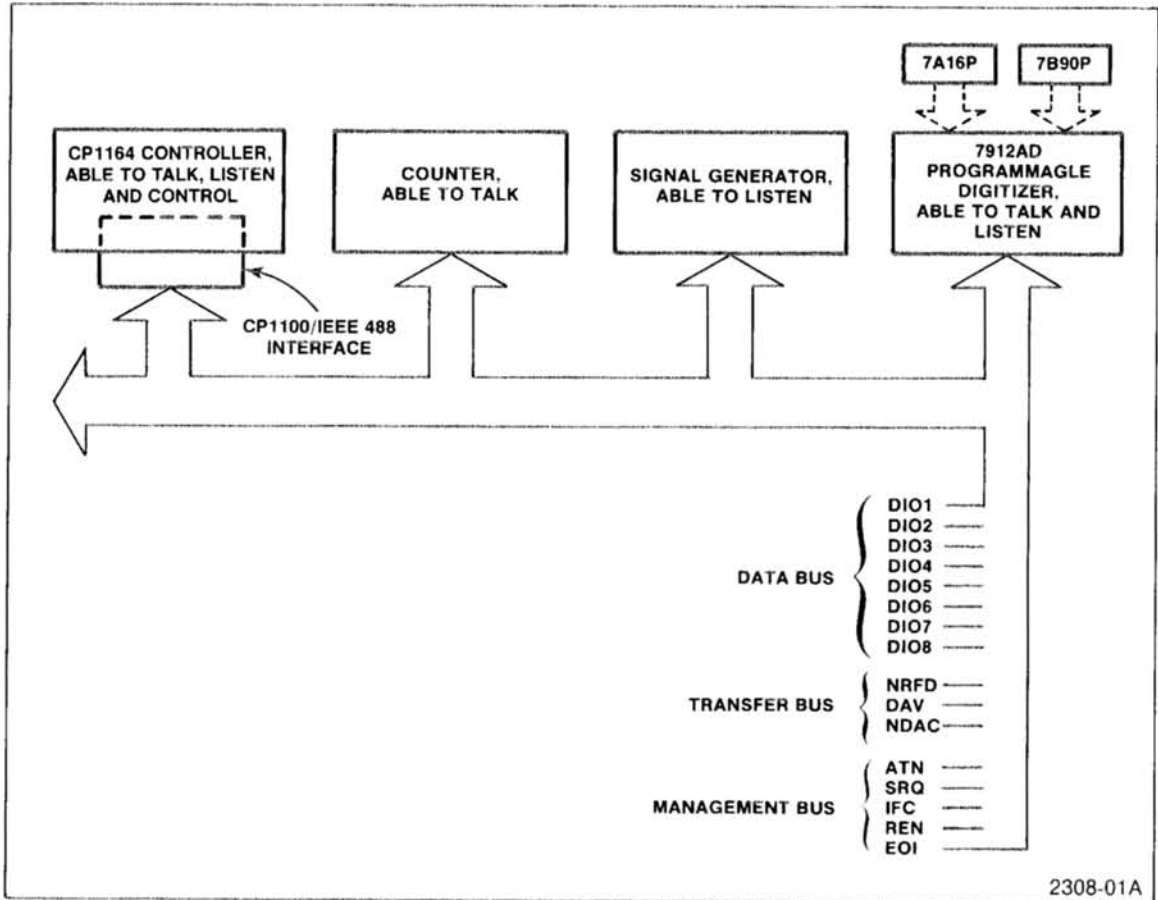

Fig. 3-1. A typical system based on the IEEE 488 bus.

Types of Messages. Messages on the bus are either interface messages or device-dependent messages. Interface messages are used to manage the interface functions of the instruments. They designate talkers and

7A16P INSTRUCTION

listeners, determine local or remote operation of devices, indicate service requests, and communicate other important interface conditions. Device-dependent messages, by contrast, are not used to change the state or configuration of the interface, but are used to control the operating modes or device functions of designated instruments. Device-dependent messages can also be data, such as waveform data generated by the TEKTRONIX 7912AD Programmable Digitizer.

Maximum Number of Devices. Up to 15 devices can be connected on the IEEE 488 bus. More than 15 devices can be interfaced if they are not directly connected to the bus but are interfaced through another device. Such a scheme is used for the 7A16P plug-in housed in a 7000-Series programmable mainframe such as the 7912AD; the mainframe provides a transparent interface between the IEEE 488 bus and the plug-ins. Secondary addresses are used for the plug-ins. More than half of the main devices connected at any time must be powered-up for the system to be operational.

Maximum Cable Length. The maximum length of cable that can be used to connect a group of devices on the bus is:

- 1) 2 meters times the number of devices
- 2) Or 20 meters, whichever is less.

Cables may be connected in either a star or linear configuration, or in a combination of the two methods.

Electrical Specifications. The relationship between the binary logic states of the bus and the voltages present on the signal lines is as follows:

Logical 1 corresponds to a low voltage level (+0.8 V or less) and the signal is said to be "asserted".

Logical 0 corresponds to a high voltage level (at least +2.0 V) and the signal is said to be "unasserted".

The electrical states are based on standard TTL (Transistor-Transistor Logic) levels where the power source does not exceed +5.25 Volts DC referenced to logic ground.

Bus Signal Lines

The IEEE 488 bus is functionally divided into three component busses: an eight-line Data Bus, a three-line Transfer (or handshake) Bus, and a five-line Management Bus. This bus structure is diagrammed in Fig. 3-1.

The eight lines of the **Data Bus** (DI01 through DI08) are bidirectional active-low lines used to convey data or device-dependent messages. Device addresses and universal commands are also transferred over these lines when ATN is asserted. One byte of information is transferred over the bus at a time. DI01 represents the least significant bit in the byte; DI08 represents the most significant bit. Data is transferred in byte-serial, bit-parallel fashion. Data bytes can be formatted in ASCII with or without parity, or they can be formatted in machine-dependent binary code. The term "machine-dependent binary code" refers to an internal binary format used by a device to store certain programs and data.

The **Transfer Bus** is used to communicate a handshake sequence that is executed between the talker and all designated listeners each time a byte is transferred over the Data Bus. This handshake sequence prevents the talker from placing a new byte on the bus until the slowest listener has captured the previous byte. Thus the talker can not transmit at a rate faster than can be received by the slowest listener. The three active-low lines of the Transfer Bus are NRFD, DAV, and NDAC. (See Fig. 3-2 for a basic timing relationship between these signals). Their functions are:

NRFD (Not Ready For Data) -- This signal line is asserted, until all assigned listeners are ready to receive the next data byte. When all of the assigned listeners have released NRFD, the NRFD signal is unasserted, thereby allowing the talker to place the next byte on the Data lines.

DAV (Data Valid) -- The DAV signal line is asserted by the talker shortly after placing a valid byte on the Data lines. This tells each listener to capture the byte presently on the Data lines. DAV can not be asserted until NRFD has been unasserted.

NDAC (Not Data Accepted) -- This signal line is asserted by each listener until all have captured the byte currently on the Data lines.

7A16P INSTRUCTION

When the slowest listener has captured the data byte, NDAC is unasserted, thereby allowing the talker to remove the byte from the Data lines. At that point, the DAV line is unasserted and the entire handshake cycle is repeated.

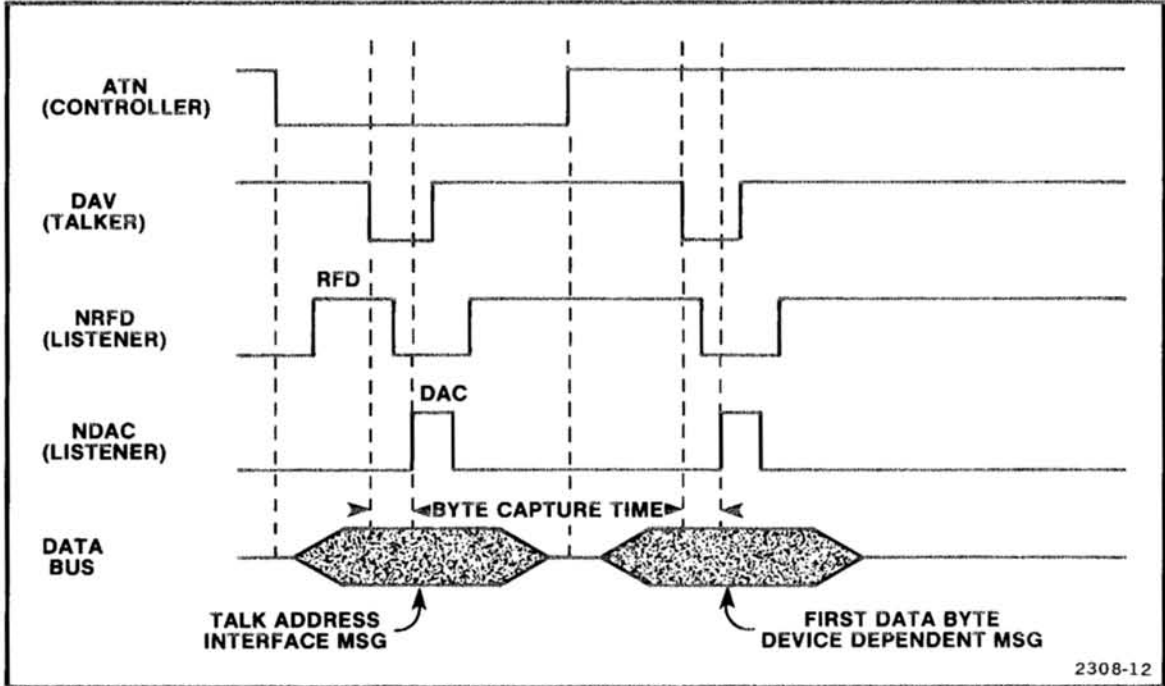

Fig. 3-2. A typical handshake sequence.

The **Management Bus** is a group of signal lines used to control data transfers over the Data Bus. These lines communicate important interface messages such as detecting an interrupt from a device, setting a device to remote control, and denoting the end of a message. The five active-low signal lines are ATN, IFC, SRQ, REN, and EOI; their functions are:

7A16P INSTRUCTION

ATN (Attention) -- Asserted by the controller-in-charge to specify how information on the Data Bus is to be interpreted. When ATN is not asserted, the information on the Data Bus is interpreted as device-dependent messages and data. When ATN is asserted, the Data Bus conveys universal commands, addressed commands, talk addresses (MTA), listen addresses (MLA), or secondary addresses (MSA). Just which addresses and commands are sent depends upon the byte currently on the Data Bus. The codes corresponding to various commands and addresses are defined in Appendix E of the IEEE 488 standard.

IFC (Interface Clear) -- Asserted by the system controller to initialize the interface functions of all instruments to a quiescent state and return control to the system. The IFC function does the same thing as UNListen, UNTalk, Serial Poll Disable and resets all devices except the system controller to the idle state.

SRQ (Service Request) -- Asserted by an instrument to request service from the controller-in-charge. The controller usually interrupts its current task and conducts a serial poll to determine which device interrupted. The controller can then branch to an interrupt service routine where appropriate action is taken. After the interrupt has been processed, the controller may resume execution of the previous task.

EOI (End Or Identify) -- Asserted by a talker to indicate the last byte of its message. When EOI is asserted with ATN, the controller conducts a parallel poll of the devices connected to the bus.

REN (Remote Enable) -- Asserted by the controller-in-charge to allow devices on the bus to go to Remote mode, thereby allowing remote control of their programmable functions. When in Remote mode, the front panels of the instruments are disabled except for any non-programmable functions.

Bus Messages

As previously noted, messages on the Data Bus are either interface messages or device-dependent messages. When the ATN line is asserted by the controller, all devices "pay attention" since interface messages are to be transferred over the Data lines. (By "pay attention" it is meant that all devices handshake and process all bytes transferred on the bus.) Interface messages can generally be classified as follows:

- 1) talk addresses
- 2) listen addresses
- 3) secondary addresses
- 4) universal commands
- 5) addressed commands

The first three categories refer to how a device is to be addressed. That is, they designate whether a device is to be a talker or a listener. To designate a device as a talker, the controller asserts ATN and places the device's talk address on the Data lines. Similarly, the controller designates a listener by asserting ATN and placing the address of the listener on the Data lines. In cases where secondary addressing is designed into a particular device, it is necessary to transmit the device's secondary address following the primary talk or listen address.

The fourth category listed above (universal commands) consists of those interface commands which affect all instruments connected to the bus, regardless of whether they are currently addressed as talker or listeners. Examples of universal commands are LLO (Local Lockout) and DCL (Device Clear).

The fifth category in the preceding list (addressed commands) consists of those interface commands which affect all instruments currently addressed as listeners. Examples of addressed commands are GTL (Go To Local) and GET (Group Execute Trigger). A complete list of universal and addressed commands is provided in Appendix E of the IEEE 488 standard.

In contrast to interface messages, device-dependent messages are sent with ATN unasserted and are transmitted only between a designated talker and one or more designated listeners. A device-dependent message can be either an instruction (e.g., set the input polarity to normal) or

7A16P INSTRUCTION

data (e.g., 3.456 volts). The format of instructions and data is entirely up to the device designer. Instructions and data are normally coded in ASCII or binary, but this is not required by the IEEE standard.

This has only been a brief introduction to the IEEE 488 interface. Further information can be found in IEEE Standard 488-1975, **IEEE Standard Digital Interface for Programmable Instrumentation**. A detailed description of the actual handshake timing sequence is covered in Appendix B of the standard.

7A16P Interface Function Subsets

The IEEE 488 standard is designed in such a way that not all devices on the bus need to have the same capability to comply with the standard. The instrument designer can choose from a "menu" of device functions, and implement only those capabilities (known as "functional subsets") that are appropriate to a particular device. The functional subsets are described in detail in the standard. The degree to which the 7A16P implements each of the ten interface functions is described below.

1) Source Handshake Function: SH1

The SH function provides a device with the ability to initiate and terminate transfer of multiline messages on the Data Bus. The 7A16P, in conjunction with the mainframe, conforms to subset SH1, meaning it has full capability with no states omitted.

2) Acceptor Handshake Function: AH1

The AH function provides a device with the capability to guarantee proper reception of messages on the Data Bus as well as the capability of delaying initiation or termination of such messages. The 7A16P conforms to subset AH1, meaning it has full capability with no states omitted.

3) Talker Function: TE6

The T function enables a device to send device-dependent data (including status information) over the bus to other devices. The 7A16P conforms to subset TE6, meaning it is an extended talker honoring secondary addresses. It has full capability except that it does not have a Talk-Only mode.

4) Listener Function: LE4

The L function allows a device to receive device-dependent data over the bus from other devices. This capability exists only when the device is addressed to listen. The 7A16P conforms to subset LE4, meaning it is an extended listener honoring secondary addresses. It has full capability except that it does not have a Listen-Only mode.

7A16P INSTRUCTION

- 5) **Service Request** Function: SR1
The SR function enables a device to asynchronously request service from the controller-in-charge of the interface. The 7A16P conforms to subset SR1, meaning it has full capability.

- 6) **Remote/Local** Function: RL1
The RL function provides a device with the capability to select between two sources of information: remote (programmed control) or local (front-panel control). The 7A16P, in conjunction with the mainframe, conforms to subset RL1, meaning it has full capability.

- 7) **Parallel Poll** Function: PPØ
The PP function allows a device to present one bit of status to the controller-in-charge without being previously addressed to talk. The 7A16P conforms to subset PPØ, meaning it has no capability for responding to a parallel poll.

- 8) **Device Clear** Function: DC1
The DC function allows a device to be cleared (initialized) either by itself or as a group of devices. The 7A16P conforms to subset DC1, meaning it has full capability. When the 7A16P receives a DCL (Device Clear) interface message, its internal buffers are cleared and the front panel is set to the power-up state. However, DCL does not affect plug-in settings in Local mode.

- 9) **Device Trigger** Function: DTØ
The DT function allows the operation of a device to be triggered (initiated) either individually or as part of a group. The 7A16P conforms to subset DTØ, meaning it has no capability for individual triggering. (The 7A16P is always in operation as long as it is installed in an operating mainframe.)

- 10) **Controller** Function: CØ
The C function provides a device with the capability for sending device addresses, universal commands, and addressed commands over the bus. The 7A16P conforms to subset CØ, meaning it cannot serve as controller.

Addressing the 7A16P

It was noted previously that two types of communication occur on the IEEE 488 bus: interface messages and device-dependent messages. The first type of communication occurs when the system controller asserts ATN and begins sending messages to all devices on the bus. The second type of communication occurs when ATN is unasserted; in this case, communication occurs only between a designated talker and one or more designated listeners.

Interface messages can occur without the assignment of talkers and listeners since, by definition, the controller has an active source handshake and all other devices have an active acceptor handshake. On the other hand, before a device-dependent message can be sent, a talker must be assigned and at least one listener must be assigned. The process of assigning talkers and listeners is referred to as "addressing".

Addressing Schemes

There are two types of addressing schemes allowed by the IEEE 488 standard: primary addressing and secondary addressing. It is up to the device designer to decide which type of addressing scheme is to be implemented on a particular device. That is, some devices use only primary addressing while others require secondary addressing. The 7A16P and its mainframe use a secondary addressing scheme.

On a device that uses **primary addressing**, up to 31 possible talk or listen addresses can be assigned to a particular device. Once a talk or listen address has been assigned to a device, this address becomes the "name" by which the controller refers to that device. However, this "name" can usually be changed since the address is generally determined by a bank of switches on the back panel of the instrument. (In some cases, the address is determined by straps on a circuit board inside the instrument.)

On a device that uses **secondary addressing**, a slightly different scheme is used. In this case, there are still 31 possible talk or listen addresses available. However, for each primary address there can be 31 possible secondary addresses corresponding to the primary address. This allows a total of 961 possible addresses for a device incorporating

7A16P INSTRUCTION

secondary addressing. Secondary addressing is sometimes used on instruments incorporating plug-in modules. An example is the TEKTRONIX 7912AD Programmable Digitizer and its two programmable plug-ins: the 7A16P and the 7B90P.

Primary and secondary addresses are sent over the Data Bus with ATN asserted. Data lines DI01 through DI05 are used to convey the actual device address. DI01 corresponds to the least significant bit and DI05 corresponds to the most significant bit. Data lines DI06 and DI07 determine whether this address is to be interpreted as a primary talk address (abbreviated MTA for My Talk Address), a primary listen address (abbreviated MLA for My Listen Address), or as a secondary address (abbreviated MSA for My Secondary Address). Incidentally, if DI06 and DI07 are 00, lines DI01-5 correspond to a universal or addressed command rather than a device address. This scheme is diagrammed in Fig. 3-3.

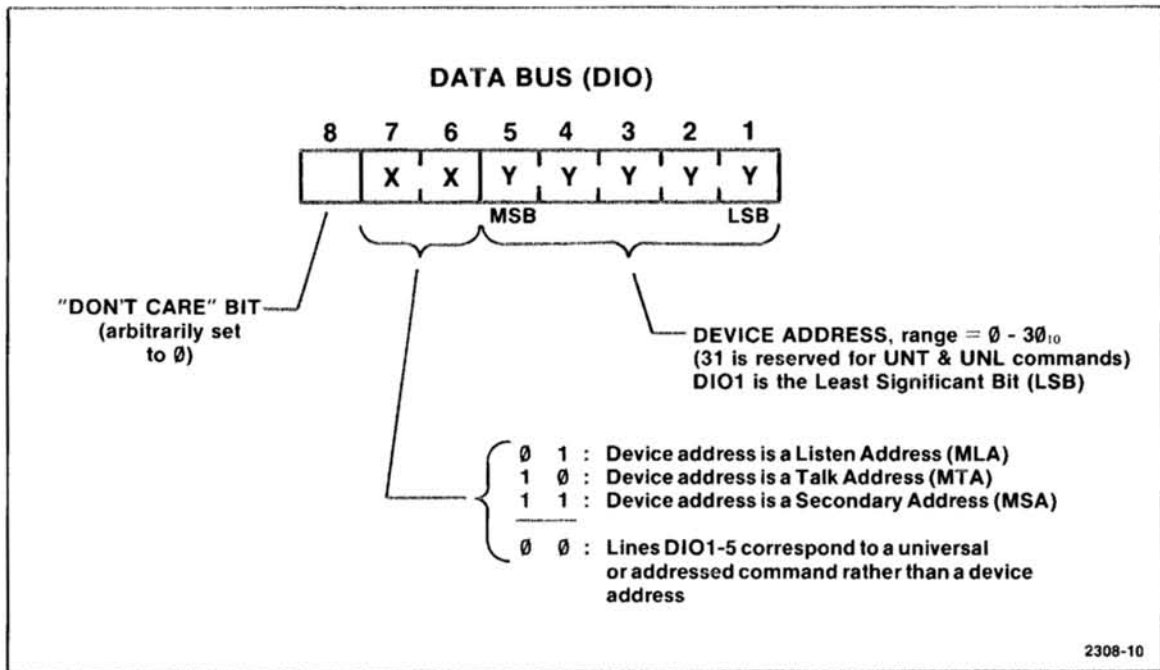

Fig. 3-3. Interpretation of the Data Bus (DIO1-8) when ATN is asserted.

Determining Device Addresses

The 7A16P does not have any provision for changing its device addresses since these addresses are a function of the mainframe in which the plug-in is installed. In the case of the TEKTRONIX 7912AD Programmable Digitizer, the MSA of the plug-in installed in the vertical compartment (such as the 7A16P) is interpreted to be the MSA of the 7912AD plus 1. Similarly, the MSA of the plug-in installed in the horizontal compartment (such as the 7B90P) is interpreted to be the MSA of the 7912AD plus 2. However, this rule is not necessarily true for all mainframes. Refer to the manual for your particular mainframe if you need more information on this point.

So far, we have talked about addressing in general terms but have not discussed the actual procedure for addressing the 7A16P for a talk or listen operation. Perhaps an example using the 7912AD will best illustrate the method. Suppose that the 7912AD is set for a primary address of 000000 and a secondary address of 000001. According to the scheme previously mentioned, the MLA, MTA, and MSA of the mainframe are:

$$\text{MLA} = 01000000 = 40_8 = 32_{10} = 20_{16}$$

$$\text{MTA} = 10000000 = 100_8 = 64_{10} = 40_{16}$$

$$\text{MSA} = 11000001 = 141_8 = 97_{10} = 61_{16}$$

To address the 7A16P as a listener, the controller asserts ATN and sends the MLA of the mainframe (32_{10}) on the Data Bus. With ATN still asserted, the controller sends the MSA of the 7A16P (98_{10}) on the Data Bus. Recall that the MSA of the vertical plug-in is that of the 7912AD plus 1. ATN can now be unasserted so that the talker can begin sending device-dependent messages to the 7A16P.

To address the 7A16P as a talker, the controller asserts ATN and sends the MTA of the mainframe (64_{10}) on the Data Bus. With ATN still asserted, the controller sends the MSA of the 7A16P (98_{10}) on the Data Bus. ATN can now be unasserted so that the listener(s) can begin receiving device-dependent messages from the 7A16P.

High-Level Messages

7A16P high-level messages are device-dependent and therefore are not specified in the IEEE 488 standard. However, these high-level messages do conform to Tektronix standards intended to enhance Tektronix compatibility with other bus-compatible instruments. To accomplish this, codes and syntax are designed to be unambiguous, to correspond to those used by other Tektronix devices, and to be as simple and obvious as possible. This minimizes the cost and time required to program the 7A16P by making it easier for the programmer to write and understand the needed device-dependent code.

The 7A16P responds to device-dependent messages that contain one or both of two types of commands: Set and Query. During a Set command, the plug-in acts as a listener and uses the incoming information to effect certain operating modes or front-panel settings. During a Query command, the plug-in initially acts as a listener until receiving an UNListen command; then the plug-in is made a talker and returns the status of a specified function or operating parameter. The syntax of a Set and Query command is explained later.

A device-dependent message begins when the plug-in is addressed as a talker or listener, with ATN asserted. Then ATN is unasserted and the actual device-dependent code is transmitted from talker to listener. The message is terminated when EOI is asserted. EOI is sent concurrent with the last byte of the message, whether it be a data byte, a delimiter, or a format character.

When special driver software is being used, the user need not concern himself with all the details of initiating and terminating each message, since this is done automatically by the software. Most of this section thus deals with message syntax rather than message transmission. However, for those who are not using special driver software, a brief discussion is included later as to the methods of initiating and terminating a message.

Explanation of Command Syntax

In describing the syntax of high-level commands, a modified form of the Backus-Naur format is used. According to this format, descriptive words such as "header", "format", or "argument" are enclosed in angle brackets (<>). Optional items are enclosed in square brackets ([]). An ellipsis (...) indicates that the preceding argument may be repeated one or more times. Punctuation marks such as the semicolon and question mark are listed exactly as they are typed; hence they are not enclosed in angle brackets.

The syntax allows format characters at several points in each command. Where they are allowed, the word "format" is spelled out. Format characters are always optional, so the word "format" is always shown in brackets. A format item can be a space, carriage return, line feed, or any combination of these characters.

Set Commands

Unless specifically designated as query (read) only, the headers and arguments listed in Table 3-1 can be used to form Set commands. Set commands are used to set the states of the various 7A16P programmable functions. A Set command for the 7A16P has the following syntax:

```
[<format>]<header><header delimiter>[<format>]<argument>
```

As previously noted, a format character is optional and may be a carriage return, line feed, space, or any combination thereof. The header delimiter is a space and is always required. The following are all examples of legal Set commands, where <cr> denotes a carriage return and <lf> denotes a line feed:

- 1) POL INV
- 2) <lf>POL INV
- 3) <cr>POL INV
- 4) <cr><lf> POL INV
- 5) V/D .05
- 6) <cr> V/D .05

Examples 1 through 4 set the amplifier POLarity to INVerted mode and

7A16P INSTRUCTION

examples 5 and 6 set the Volts/Division to 0.05.

One or more Set commands can be included in the same message as explained later under the heading "Messages".

Query Commands

All of the headers in Table 3-1 can be used to form Query commands. Query commands are used to determine the states of the various 7A16P programmable functions. A Query command has the following syntax:

```
[<format>]<header>?
```

Again, [<format>] refers to an optional carriage return, line feed, space, or any combination thereof. The question mark (?) following the header argument must be typed without a preceding space or other format character.

Examples of Query commands are:

- 1) POL?
- 2) <cr>POL?
- 3) <cr><lf> POL?
- 4) V/D?
- 5) <lf>V/D?

Examples 1 through 3 query the state of the POLarity switch and examples 4 and 5 query the setting of the Volts/Division switches.

7A16P INSTRUCTION

TABLE 3-1

7A16P HIGH-LEVEL (ASCII) COMMAND SET

HEADER	ARGUMENT	DESCRIPTION
INP	A	Input is from A connector.
	B	Input is from B connector.
RIN	HI	High (1 Megohm) input impedance is selected.
	LOW	Low (50 ohm) input impedance is selected.
CPL	AC	Input is AC coupled.
	DC	Input is DC coupled.
	GND	Input is grounded.
BW	LIM	Limited bandwidth (20 MHz) is selected.
	FUL	Full bandwidth is selected.
POL	NOR	Amplifier polarity is normal.
	INV	Amplifier polarity is inverted.
V/D	xxxx	Volts/Division is set to xxxx; argument must be a number in the range of 0.01 to 5 in a 1, 2, 5 sequence. 1,2 V/D Ø means probe is on IDENTIFY.
POS	xxxx	Vertical Position of trace (from center screen) is set to xxxx; range is -10.22 to +10.24 in 0.02 steps (example: POS 2 corresponds to +2 div.). 3
VAR	OFF	Variable off -- deflection factors are calibrated.
	ON	Variable on -- deflection factors are uncalibrated.
		(NOTE: The following commands are read only, or query.)
PRB	X1	1X or unencoded probe is present on selected input.
	X1Ø	1ØX probe is present on selected input.
	X1ØØ	1ØØX probe is present on selected input.

7A16P INSTRUCTION

ID		Returns the plug-in type: TEK/7A16P,V77.1,LLL This means Tektronix 7A16P with language version 77.1, and low-level language. ⁴
SET		Returns the settings of all of the above functions with the exception of the ones that are read-only.

FOOTNOTES

- 1 Will accept <nr1>, <nr2>, or <nr3> numerical format, as defined in ANSI Standard X3.42. Response to queries is in <nr3>.
- 2 With a 10X probe on selected input, allowable range is 0.1 to 50. With a 100X probe, allowable range is 1 to 500. If a probe is identifying when a Set V/D command is executed, no operation is performed, and an execution error is reported. If a probe is identifying when a Query V/D command is executed, 0 is returned.
- 3 Will accept <nr1>, <nr2>, or <nr3>; responds with <nr2>.
- 4 The 77.1 nomenclature refers to the version of protocol implemented; it may be updated at a future date.

Summary of ANSI X3.42 Numerical Formats

<nr1> Signed or unsigned integers (no decimal point) preceded optionally by spaces (<sp>). The <nr1> representation of value "zero" must not contain a minus sign.

Examples: +1245, <sp>-328, <sp><sp>475, +0000

<nr2> Signed or unsigned numbers with a decimal point preceded optionally by spaces (<sp>). The <nr2> representation of value "zero" must not contain a minus sign.

Examples: 0.123, <sp>+5.41, -6.420, <sp><sp>0.000

<nr3> Floating-point numbers expressed in modified scientific notation. The mantissa always includes a decimal point and is preceded by sign (+, -, or <sp>). The exrad following the mantissa begins with the character E followed by a plus or minus sign and then one or more digits for the exponent. The <nr3> representation of value "zero" must contain an <nr2> zero followed by an exrad with plus sign and all zero digits.

Examples: -1.5E+03, <sp>2.E-1, +5.0E-2, +0.0E+00

Messages

A Set or Query command is referred to as a "message unit". One or more message units can be concatenated to form a message, if each unit is delimited by a semicolon (;). Using the preceding terminology, the syntax of a message may be described as:

```
<message unit>[;[<format>]<message unit>]...[;][<format>]
```

Notice that format characters may be included but are not required. Also, the ellipsis indicates that one or more message units, and accompanying optional format characters, may be included if they are delimited by a semicolon.

The simplest message consists of a single Set or Query command. For example, the following Set message sets the amplifier sensitivity to 0.5 Volts/Division.

```
V/D 0.5
```

Similarly, the following Query message reads the setting of the Volts/Division switches:

```
V/D?
```

When the 7A16P is made a talker, it responds by sending the current Volts/Division setting. For the case of the preceding example, the following query response would be obtained:

```
V/D 5.E-1
```

This indicates that the Volts/Division setting is 5×10^{-1} (500 millivolts/division).

Messages with Multiple Sets. More than one Set command can be sent in the same message by concatenating them with semicolons. For example:

```
RIN LOW; V/D 5
```

This message sets the input impedance low (50 ohms) and then sets the vertical scale factor to 5 Volts/Division.

7A16P INSTRUCTION

Here are some other examples of messages with multiple Set commands:

- 1) INP A; CPL DC; BW FUL; V/D .2
- 2) <cr><lf>INP A; <cr><lf>CPL DC; <cr><lf>BW FUL; <cr><lf>V/D .2

In each of the preceding two examples, there are four Set commands that accomplish the same settings, namely: INPut is selected from connector A, input CouPLing is set to DC, BandWidth is set to FULL, and the Volts/Division is set to 0.2.

Messages with Multiple Queries. In a similar fashion, more than one Query command can be executed in the same message. With the 7A16P addressed as a listener, each query is received and the results are queued internally until the plug-in is made a talker. When the 7A16P is made a talker, the results of the query are output in the same order they were received. The response to the query is valid at the time of the response, rather than at the time the query is received. The following is an example of a multiple-query message and its resulting output:

```
BW?;CPL?;POL?;V/D?  ← query message
BW FUL;
CPL DC;
POL NOR;
V/D 2.E-1 } query response
```

Notice that the results of the query are executed in sequence and that a semicolon, carriage return, and line feed are generated after all but the last response.

When more than one Query command of the same type is included in the same message, only the last occurrence of the Query is executed. For example:

```
POL?;BW?;POL?
```

Executing the preceding message would cause an output such as:

```
BW FUL;
POL NOR
```

7A16P INSTRUCTION

Since two POL? queries were executed in the same message, the first one was ignored.

The SET? Query. A special type of Query command is the SET? query. It interrogates the status of all the programmable functions of the 7A16P. The SET? query is sent just like any other query message. That is, the 7A16P is made a listener and then SET? is sent over the Data Bus. When the plug-in is made a talker, an output such as the following is obtained:

```
BW FUL;  
CPL DC;  
RIN HI;  
VAR OFF;  
V/D 5.E+0;  
POL NOR;  
POS +2.38;  
INP A
```

Normally, a SET? query will be the only query in a message. When a SET? query follows some other query in the same message, all queries preceding the SET? query are ignored. Also, any queries following the SET? query cause the SET? query to be ignored.

Messages with Sets and Queries. When Set and Query commands are included in the same message, the following action is taken: First, all Set commands are executed in the order they are received. This is true even if there is more than one Set command for the same function. After all Set commands are executed, the plug-in is made a talker and the results of the Query commands are executed in sequence. If more than one query for the same programmable function is received, all but the last occurrence of that query is ignored.

To demonstrate the effect of multiple Sets and Queries in the same message, consider the following:

```
POL NOR; POL?; POL INV; POL?
```

Executing the preceding message first sets the amplifier POLarity to NORmal momentarily. Then, without further delay, the POLarity is changed to INVerted as the next Set command is executed. With both Set commands

7A16P INSTRUCTION

executed, the queries are then executed. Since the POL? query occurs twice, only the second occurrence is honored. When the plug-in is made a talker, the following output is seen:

```
POL INV
```

Query Responses. The 7A16P responds to a query by sending the status of the queried function at the time of the response rather than at the time the query is received. A query remains valid (if the plug-in is made a talker, it will return the requested status) until one of the following occurs:

- 1) the plug-in is made a talker and sends the requested status.
- 2) a later message unit contains the same query (in this case the old query is cleared and replaced by the new one).
- 3) a DCL (Device Clear interface message) is received.

This allows you to mix Set and Query commands without regard to where the query is in the message. For example, executing:

```
BW FUL; BW?; BW LIM
```

causes a response of:

```
BW LIM
```

Similarly, executing:

```
VAR ON; SET?; VAR OFF
```

results in an output such as:

```
BW LIM;  
CPL DC;  
RIN HI;  
VAR OFF;  
V/D 5.E+0;  
POL NOR;  
POS +2.38;  
INP A
```

7A16P INSTRUCTION

Notice that in each case, the result of the query is valid as though it was included last in the message.

Low-Level Messages

All of the programmable functions of the 7A16P can be set or queried by a low-level language that is completely redundant to the high-level language. The low-level code merely provides an alternative method of communication that requires less bus time for programming the plug-in because data is moved in fewer bytes. Also, the language is decoded faster.

Unlike the high-level language which allows Set and Query commands to be combined in the same message, the low-level language requires that Sets and Queries be entered as separate messages. However, it is possible to set or query more than one function in the same message, provided certain rules of syntax are followed.

The following conventions are used in discussing the 7A16P low-level code. The term "hexadecimal" or "hex" refers to a base-16 number. Syntax items shown inside square brackets ([]) are optional and can therefore be omitted. Angle brackets (<>) are used to show that the enclosed argument is a descriptive term.

NOTE

The TEKTRONIX 7912AD Programmable Digitizer has an internal strap that allows it to generate an EOI when a linefeed is detected. If the 7912AD is strapped in this way and a 7A16P is installed, the 7A16P low-level code will not be functional. However, the high-level language will be functional if all messages to the plug-in are terminated by at least 17 spaces.

Set Messages

Both Set and Query messages are implemented in low-level code. The format of a Set message is as follows, where each line is a separate 8-bit byte representing a hexadecimal number.

```

    15
    <address>
    <data>
    [ <data> ]
      .
      .
      .
    <checksum>
  
```

The hex 15 (ASCII NAK character) identifies this message as a low-level Set message. The <address> byte specifies the starting address in 7A16P memory for storing the <data> byte(s) which follow(s). The <address> byte corresponds to a particular programmable function and the first <data> byte corresponds to the setting of that function. (See Table 3-2 for the hexadecimal codes corresponding to various functions and their settings). The allowable range for the starting address is 00 to hex 0A. This address is automatically incremented between <data> bytes if more than one <data> byte is sent. If the address is automatically incremented beyond 0A by sending too many bytes, the extra bytes are ignored. If arguments other than the ones specified in Table 3-2 are sent, the 7A16P may be set to an illegal operating mode, but no damage will result.

The checksum is the 2's complement of the modulo-256 sum of all the preceding bytes of the message (including the 15 and address byte). Therefore the modulo-256 sum of all bytes in the message, including the checksum, is zero (for a correctly transmitted block).

7A16P INSTRUCTION

TABLE 3-2

7A16P LOW-LEVEL (HEXADECIMAL) CODES

ADDRESS	ARGUMENT	DESCRIPTION
00	16	Plug-in Type (read only). Any data other than hex 16 written to this address causes a command error.
01	00 40	Input Connector Input A Input B
02	80 00	Input Impedance 50 ohms 1 Megohm
03	00 10 20	Input Coupling AC DC GND
04	05 04 06 01 00 02 09 08 0A	Volts/Division (ignores probe attenuation) 10 millivolts/division 20 millivolts/division 50 millivolts/division 100 millivolts/division 200 millivolts/division 500 millivolts/division 1 volts/division 2 volts/division 5 volts/division
05		High two bits of Position
06	03 FF 02 00 00 00	Low eight bits of Position -10.22 divisions Midscreen +10.24 divisions Step size is 0.02 div
07	00 08	Polarity Inverted Normal

7A16P INSTRUCTION

ADDRESS	ARGUMENT	DESCRIPTION
08	00	Bandwidth Limit 20 Megahertz limit
	40	Full bandwidth
09	00	Calibrated/Variable Gain Deflection factors can be manually varied by VARIABLE control.
	20	Returns deflection factors to calibrated value The position of the front panel switch for this function is not readable.
0A		Probe Attenuation (read only). A write to this address is ignored.
	00	Probe IDENTIFY switch is pressed
	04	100X probe
	14	10X probe
	1C	1X or unencoded probe

Computing the Checksum

To compute the checksum, required as the last byte of a low-level Set or Query message, do the following:

- 1) Find the hexadecimal (base-16) sum of the preceding bytes of the message.
- 2) If the sum found in step 1 is greater than hex FF (256_{10}), convert it to modulo-256 by successively subtracting FF until the remainder is less than FF but greater than 0.
- 3) Convert the remainder from step 2 to binary representation.
- 4) Find the 2's complement by complementing all bits and adding 1.
- 5) Convert the resulting number back to hexadecimal representation, if desired.

7A16P INSTRUCTION

To determine what <data> and <address> bytes are required to set a particular operating parameter, refer to Table 3-2. For example, let's suppose you wanted to set the polarity of the 7A16P to normal. By looking at the table, you note that the address of the polarity switch is 07 and the value corresponding to normal polarity is 08. Thus the following hexadecimal numbers should be entered in sequence to effect normal polarity:

```
15
07
08
DC
```

The last byte sent (DC) is the 2's complement of the modulo-256 sum of the preceding three bytes (hex 24).

Consider another example. Suppose that we want to set the following input parameters via the low-level code:

```
input impedance: 50 ohms
input coupling: DC
Volts/Div: 5
```

To effect these settings, the following hexadecimal numbers must be sent over the Data lines in the sequence listed:

```
15
02
80
10
0A
4F
```

The explanation for the above numerical sequence is as follows: First a 15 is sent to indicate the beginning of a low-level Set message. Next, a 02 is sent which is the address corresponding to the 7A16P input impedance. The 80 which follows sets the input impedance to 50 ohms. The next two numbers in the sequence (10 and 0A) set the input coupling to DC and the Volts/Div to 5, respectively. The last number in the sequence (4F) is the checksum.

When setting more than one programmable function with the same low-level Set message, it must be remembered that the address counter of the plug-in is incremented automatically if more than one data byte is sent. Thus the data bytes must be entered in sequence such that they correspond to the incremented address counter. In other words, successive Set codes can be entered only if they correspond to the normal sequence of the address counter as listed in Table 3-2. If they do not correspond, then more than one low-level Set message must be used to set more than one programmable function.

Query Messages

Using the same syntax notation as just used for Set messages, the format of a low-level Query message can be defined as:

```

    11
    [ <address> ]
    [ [<count>] ]
    <checksum>
  
```

The hex 11 (ASCII DCI character) identifies this message as a low-level Query message. The <address> byte specifies the first address in 7A16P memory to be read. The <count> byte specifies the number of addresses to be read. The <address> byte corresponds to a particular programmable function and the <count> byte designates how many successive functions are to be queried (see Table 3-2). If <address> and <count> are both omitted, all addresses are read beginning with address zero. If just <count> is omitted, only the address specified is read (count defaults to 1).

If the address specified is within range (00 to hex 0A), but <count> is too large, no error is reported; however, the output line includes data only up to and including 0A.

The checksum is always required and is computed in the same manner as for the Set message. That is, the checksum is the 2's complement of the modulo-256 sum of all the preceding bytes in the message.

To determine what <address> byte should be used in a particular Query message, refer to Table 3-2. If no <count> byte is included, the

7A16P INSTRUCTION

specified <address> byte will determine the programmable function to be queried. If a <count> byte is included, the <address> byte determines the first function to be queried, and as the address counter is incremented, additional functions following the first one queried are also queried.

As an example, suppose you wanted to query one function -- the setting of the Volts/Div switches. In this case, no <count> byte is necessary and thus the following sequence of hexadecimal numbers would work:

```
11
04
EB
```

The 11 identifies this message as a low-level query. The number following (04) is the address that contains the current setting of the Volts/Div switches. Finally, the EB is the 2's complement of the modulo-256 sum of the preceding two bytes (hex 15). When the plug-in is made a talker, the Volts/Div setting will be returned.

The response to a low-level Query message looks identical to a corresponding low-level Set message. For instance, if the setting of the Volts/Div switches is queried as in the preceding example, a response like the following hexadecimal numbers could be obtained:

```
15
04
08
DF
```

The 15 designates a low-level query response. The 04 is the <address> byte corresponding to the Volts/Div switches, and the 08 is the <data> byte corresponding to 2 Volts/Div. DF is the checksum.

Consider another example. This time let's query the state of the input connector, the input resistance, and the input coupling switches. Since these switches correspond to consecutive addresses in Table 3-2, we can query all three settings in a single low-level Query message consisting of the following hexadecimal numbers:

7A16P INSTRUCTION

11
01
03
EB

As in the previous example, the 11 identifies this message as a low-level query. The 01 which follows is the starting address in 7A16P memory that will be queried; it corresponds to the source of the input signal (i.e. connector A or Connector B). The 03 indicates that the address counter is to be incremented twice so that two more functions can be queried. These two successive functions are the input resistance and input coupling switches, corresponding to addresses 02 and 03 respectively. The message ends with the checksum EB.

The response to the above multiple-query message might be the following hexadecimal numbers:

15
01
40
80
10
1A

Again, the 15 indicates a response to a low-level query, and the 01 indicates the starting <address> byte -- which corresponds to the input connector. The next three bytes (40, 80, 10) indicate that the selected input connector is B, the input impedance is 50 ohms, and the input coupling is DC. The 1A is the checksum.

As a final example, consider the following low-level query:

11
EF

This query contains only the query designator (11) and the checksum (EF). Since the <address> and <count> bytes were both omitted, the state of all functions will be queried (addresses 00 through 0A inclusive). This is analogous to high level SET? query which indicates all states of the plug-in when the plug-in is made a talker.

Transmitting Messages

The discussion so far has centered around the syntax of the high-level and low-level messages, rather than the process by which these messages are transferred from talker to listener and vice-versa. When special driver software is being used, it is sufficient to know only the message syntax since most of the details of message transfer are handled automatically by the software. However, when using controllers for which driver software is not available, it is necessary to know something about the message protocol discussed in the IEEE 488 standard. The following information will provide these details by showing the states of the interface signal lines for typical message transfers.

Transmitting Set Messages

First, consider the case where a talker is transmitting a message to effect a certain front-panel setting on the 7A16P. Here is a summary of the steps involved:

1) **Clear the bus.** Before initiating any message transfer, it is a good idea to clear the bus of any previously assigned talker and/or listener(s). (In some cases, such as immediately following power-up, this step won't be necessary since no talker or listener will have been assigned.) To remove any talker or listener, the controller asserts ATN and sends the UNT and UNL interface messages on the Data lines. (According to Appendix E of the IEEE 488 standard, UNT corresponds to hexadecimal 5F and UNL corresponds to hex 3F.)

2) **Assign the talker and listener(s).** Before communication of device-dependent messages can occur, the controller must designate which device is to talk and which device(s) are to listen. This is done with ATN still asserted. To designate the talker, the controller sends the primary talk address (MTA) of that device. This is followed by the talker's secondary address (MSA) if secondary addressing is employed. Similarly, the controller designates the listener (the 7A16P in this case) by placing its primary listen address (MLA) on the Data lines. This must also be followed by the secondary address (MSA) of the listener since secondary addressing is employed in the 7A16P. The process is repeated for each listener on the bus, although some listeners may not have secondary addresses.

7A16P INSTRUCTION

If the ATN signal line is continuously asserted during the period when the talker and listener(s) are assigned, the order in which the talker and listener(s) are assigned is unimportant.

In the case where the controller is to be the talker, it must have addressed itself as such and any other talkers must be idle. (Its talk address does not need to be sent over the bus.)

3) **Send the device-dependent message.** With the talker and listener(s) assigned, the ATN line is now unasserted to initiate transfer of the device-dependent message.

In the case of a high-level message, each ASCII character of the message is transferred in sequence according to the previously explained syntax. Only lines DI01 through DI07 of the Data Bus are used. DI01 corresponds to the least-significant bit of each 7-bit ASCII character and DI07 corresponds to the most-significant bit. Line DI08 of the Data Bus is a "don't care" bit. As each character is transferred over the Data Bus, the entire handshake cycle is executed. This guarantees proper reception of each character before permitting a new character to be transmitted.

In the case of a low-level message, the process is similar except that all eight Data lines (DI01 through DI08) are used for transferring the message. Lines DI01-4 transfer the low-order hexadecimal digit and lines DI05-8 transfer the high-order hexadecimal digit. The handshake sequence is essentially the same as for the high-level message.

4) **Terminate the message.** As the last character or digit of the message is sent, the talker asserts the EOI signal line along with the data byte. This is to inform the controller that the talker is finished so that other operations can begin. (All Tektronix instruments functioning as talkers assert EOI automatically when outputting the last data byte of the message, but this is not necessarily true of instruments from other manufacturers -- particularly those designed prior to the formal release of IEEE 488-1975.)

5) **Clear the bus.** Though step 4 actually terminates the message transfer, it is often desirable to clear the bus of talker and listener(s) so that other operations can proceed immediately. The procedure for doing this is identical to step 1.

7A16P INSTRUCTION

As an example of the above steps, assume that the controller is to effect two front-panel settings on a 7A16P: the amplifier polarity will be set to normal, and the bandwidth limit will be set to 20 MHz. (The plug-in is installed in a 7912AD mainframe set for a primary address of 000000 and a secondary address of 000100.) The following steps would accomplish this:

- 1) The controller asserts ATN, then transmits hexadecimal 5F (UNT) and hex 3F (UNL) over Data lines DI01 through DI07.
- 2) With ATN still asserted, the controller sends hex 20 (the MLA of the mainframe) followed by hex 63 (the MSA of the 7A16P) on the Data lines. Recall from the subsection on **Addressing the 7A16P** that the MSA of the 7A16P is that of the mainframe plus 1. Since the controller is to be the talker, no talk address is sent.
- 3) a) In the case of a high-level message, the talker (controller) transmits each of the following ASCII characters over the Data lines:

POL NOR; BW LIM

-
-
- b) In the case of a low-level message, the following hexadecimal bytes are transferred over the Data lines:

15
07
08
00
DC

-
-
-
- 4) As the last character or hex byte is transmitted, the talker asserts EOI indicating the end of the message.
- 5) The controller again clears the bus by transmitting 5F (UNT) and 3F (UNL) over the Data lines.

Figure 3-4 illustrates the above sequence more graphically.

Figure 3-4 does not indicate the status of the IFC, REN, and SRQ signal lines because they are relatively unimportant to the point being

7A16P INSTRUCTION

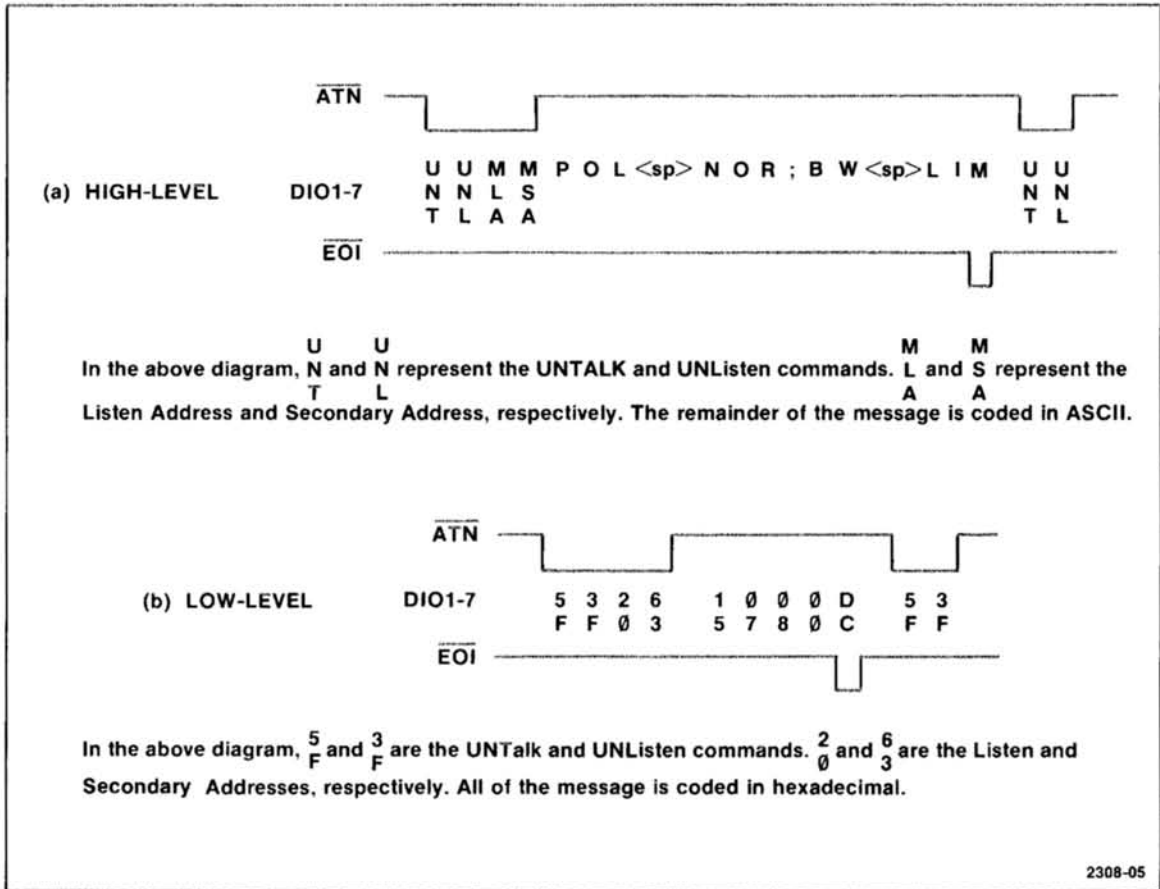

Fig. 3-4. Status of the ATN, EOI, and DIO signal lines during a high-level (a) and low-level (b) Set message.

made. However, it should be understood that the REN (Remote Enable) line is continuously asserted whenever the plug-in is being operated under remote (program) control, as opposed to local (front-panel) control. The IFC line will normally be unasserted during the entire sequence. The SRQ line can be asserted whenever a device requests service. However, it is not relevant to the process of data transmission diagrammed in Fig. 3-4 and is not shown.

While the handshake lines (DAV, NRFD, and NDAC) are important in the transmission of messages and data, their status changes several times during the transmission of each character in the message. Appendix B of

the IEEE 488 standard gives a detailed description of this handshake cycle.

Transmitting Query Messages

The previous sequence describes the process for transmitting a Set message -- in which case the plug-in is always a listener. A similar sequence occurs when a Query message is sent to the plug-in. However, in this case the plug-in is first made a listener so that it can receive the Query message; then the plug-in is made a talker so that it can transmit its response to the query. Here is a summary of the steps involved:

1) **Clear the bus.** As previously noted, this step is not always necessary but is good practice. The controller asserts ATN and sends UNT (hex 5F) and UNL (hex 3F) on the Data lines.

2) **Assign the talker and listener(s).** The controller designates which device is to send the query and which device or devices are to receive the Query message. This is done with ATN still asserted. To designate the talker, the controller sends the primary talk address (MTA), followed by the talker's secondary address (MSA) if secondary addressing is used for that device. Similarly, the controller designates the listener (the 7A16P in this case) by sending its primary listen address (MLA) and secondary address (MSA). This process is repeated for each listener on the bus.

When the controller is to be the talker, it must have addressed itself as such and any other talkers must be idle. (Its talk address does not need to be sent over the bus.)

3) **Send the device-dependent query.** With the talker and listener(s) assigned, the ATN line is now unasserted to initiate transfer of the device-dependent query. Each ASCII character or hex byte of the message is transferred in sequence over the Data lines according to the previously explained syntax.

4) **Terminate the query.** As the last character or digit of the high-level query or series of queries is sent, the talker asserts EOI along with the message byte. This informs the controller that the talker is finished so that the query response can proceed.

7A16P INSTRUCTION

5) **Clear the bus.** At this point it is necessary to clear the bus so that the plug-in can be addressed as a talker. Again, this is done by the controller asserting ATN and by sending the UNT and UNL interface commands over the Data lines.

6) **Assign the talker and listener(s).** With ATN still asserted, the controller now assigns the plug-in as a talker and assigns any additional listeners. If the controller is to be the only listener, it does not need to address itself as a listener.

7) **Send the device-dependent query response.** The ATN line is now unasserted by the controller to initiate transfer of the query response from the talker (plug-in) to any designated listener(s). Each ASCII character or hex byte of the query response is transmitted over the Data lines according to the previously described syntax for a query response.

8) **Terminate the query response.** As the last character or digit of the query response is sent, the talker (plug-in) asserts EOI along with the data byte, thereby indicating the end of the response.

9) **Clear the bus.** Though not required for this operation, the controller can now clear the bus of talker and listener(s) so that further operations can proceed.

As an example of the above steps, assume that the controller is to query and receive the status of two front-panel functions on the 7A16P: the input coupling and the Volts/Division settings. (The plug-in is installed in a 7912AD mainframe set for a primary and secondary address of 00011.) The following steps describe the operations involved:

- 1) The controller asserts ATN, then transmits hexadecimal 5F (UNT) and 3F (UNL) over the Data lines, thereby clearing the bus.
- 2) With ATN still asserted, the controller transmits hexadecimal 23 (the MLA of the mainframe) followed by hex 64 (the MSA of the 7A16P) over the Data lines. This assigns the 7A16P as a listener.
- 3) a) In the case of a high-level message, the talker (controller) transmits each of the following ASCII characters over the Data lines:

7A16P INSTRUCTION

CPL?; V/D?

b) In the case of a low-level message, the following hex bytes are transferred over the Data lines:

11
03
02
EA

- 4) As the last character of the query is transmitted, the talker (controller) asserts EOI.
- 5) The controller clears the bus of talkers and listeners by asserting ATN and sending hex 5F and 3F on the Data lines.
- 6) With ATN still asserted, the controller transmits hexadecimal 43 (the MTA of the mainframe) followed by hex 64 (the MSA of the 7A16P) over the Data lines. This assigns the 7A16P as a talker.
- 7) The talker (7A16P) now sends its query response to the listener (controller).
- 8) As the last character of the query response is transmitted, the talker (7A16P) asserts EOI.
- 9) The controller again clears the bus by asserting ATN and sending hex 5F and 3F.

Figure 3-5 illustrates the state of the ATN, EOI, and Data lines for the above sequence and a typical query response.

7A16P INSTRUCTION

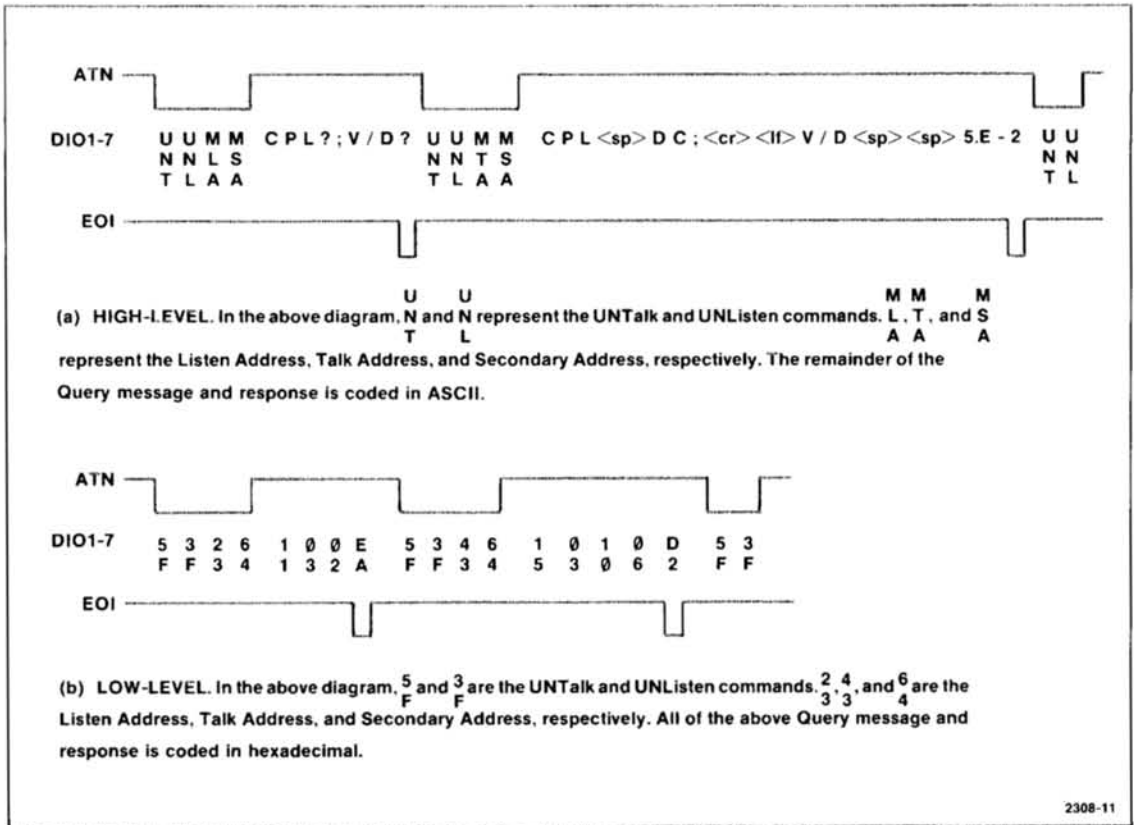

Fig. 3-5. Status of the ATN, EOI, and DIO signal lines during a high-level (a) and low-level (b) Query message and response.

Serial-Poll Responses

The 7A16P reports any of the following errors or special conditions when polled by the controller:

- 1) Power on
- 2) Command error
- 3) Execution error
- 4) Busy

If any of the above conditions (except Busy) occurs, the 7A16P asserts the SRQ line to initiate a serial poll. The controller, if programmed to do so, can then process the interrupt and provide an appropriate response. The following is a detailed description of each of the four conditions:

1) **Power on:** Occurs whenever the plug-in goes through its initialize sequence, either at the time that power is first applied or when it is reapplied following momentary interruption.

The serial-poll response byte is $\emptyset 10x\emptyset\emptyset\emptyset 1$, where x is a 1 if the 7A16P is busy, and a \emptyset otherwise.

2) **Command error:** Occurs whenever the plug-in cannot understand or implement the data it receives.

Command errors detected for low-level messages are: (a) the message is more than 16 bytes long, (b) the modulo-256 sum of all bytes in the message is not zero, (c) the starting address is too large, (d) no address is supplied with a Set message, or (e) an attempt was made to set address \emptyset (plug-in type) to the wrong value.

Command errors detected for high-level messages are: (a) syntax is incorrect, (b) a Set command refers to a read-only function, or (c) message units are not recognized by the 7A16P.

If an error is detected in a low-level message, the 7A16P ignores the entire command line. If the error is a low-level query address out of range, the output queue is cleared (i.e. if there are any query-responses pending, they are cleared).

7A16P INSTRUCTION

If an error is detected in a high-level message, any message unit preceding the one with the error is processed normally. The one with the error and any following are ignored.

The serial-poll response byte for a command error is $011x0001$, where x signifies the busy status.

Occasionally, the 7A16P may be addressed as a talker, but have nothing to say. When this occurs, the plug-in sends a data byte with all Data lines set to logical 1 (hex FF) and EOI asserted. Also, the plug-in reports a command error.

3) **Execution error:** Occurs when the numerical argument for a high-level Set command is invalid or out of the allowable range. The command for that function is ignored, as are any subsequent commands in the same message.

The serial-poll response byte for this type of programming error is $011x0010$, where x signifies the busy status.

4) **Busy:** Occurs when a serial poll is performed while the plug-in is decoding a command; the response is $xxx1xxxx$. When not busy, the response is $xxx0xxxx$ (x is a "don't care" bit). The plug-in will not accept data on the bus while reporting busy.

The 7A16P queues power-up, command error, and execution error reports. If two or three conditions are waiting to be reported, SRQ is reasserted after reporting one error to indicate that there is more to report.

If an error is found in a high-level command string, SRQ is not asserted and the error is not reported until the message has been completely received (i.e. a byte with EOI asserted is received).

SECTION 4

MAINTENANCE

This section of the manual contains maintenance information for use in preventive maintenance, corrective maintenance, and troubleshooting of the 7A16P.

Further maintenance information relating to general maintenance can be found in the instruction manuals for the 7000-series mainframes.

Preventive Maintenance

Preventive maintenance, consisting of cleaning, visual inspection, etc., performed on a regular basis, will improve the reliability of this plug-in unit. Periodic checks of the semiconductor devices used in the unit are not recommended as a preventive maintenance measure. See semiconductor-checking information given under Troubleshooting.

The severity of the environment to which this unit is subjected determines the frequency of maintenance. A convenient time is preceding adjustment of the instrument.

Cleaning

CAUTION

Avoid the use of chemical cleaning agents which might damage the plastics used in this unit. Special care should be taken when cleaning the fire-retardent polysulphone attenuator board. Do not apply any solvent containing ketones, esters or halogenated hydrocarbons. To clean, use only water soluble detergents, ethyl, methyl or isopropyl alcohol. (Special precautions must also be exercised when soldering on the attenuator board; refer to the discussion of soldering techniques).

7A16P INSTRUCTION

Exterior. Loose dust may be removed with a soft cloth or a dry brush. Water and mild detergent may be used; however, abrasive cleaners should not be used.

Interior. Cleaning the interior of the unit should precede calibration, since the cleaning process could alter the settings of the calibration adjustments. Use low-velocity compressed air to blow off the accumulated dust. Hardened dirt can be removed with a soft, dry brush, cotton-tipped swab, or cloth dampened with a mild detergent and water solution.

Visual Inspection

This instrument should be inspected occasionally for such defects as broken connections, improperly seated semiconductors, damaged circuit boards, and heat-damaged parts.

The corrective procedure for most visible defects is obvious. However, particular care must be taken if heat-damaged components are found. Overheating usually indicates other trouble in the instrument; therefore, it is important that the cause of overheating be corrected to prevent recurrence of the damage.

Lubrication

Generally, there are no components in this instrument that require a regular lubrication program during the life of the instrument.

Troubleshooting

The following is provided to augment information contained in other sections of this manual when troubleshooting the 7A16P. The schematic diagrams, circuit description, and calibration sections should be used to full advantage. Section 5 gives detailed information on circuit behavior.

Troubleshooting Aids

Schematic Diagrams. Schematic diagrams are provided on foldout pages in Section 8. The circuit number and electrical value of each component are shown on the diagrams. Power supply voltages are also shown. Components that are mounted on circuit boards are outlined on the diagrams with a heavy black line.

Circuit-Board Illustrations. Illustrations of circuit boards are shown opposite the schematic diagrams. Each board-mounted electrical component is identified by its circuit number.

Component-Locator Grids. Schematic diagrams and circuit board illustrations are bounded by component-locator grids. When used with the associated lookup tables, these grids allow you to quickly locate a component on either the schematic or the circuit board.

Component and Wiring Color Code. Colored stripes or dots on resistors and capacitors signify electrical values, tolerances, etc., according to the EIA standard color code. Components not color-coded usually have the value printed on the body.

The insulated wires used for interconnection in the 7A16P are color-coded to facilitate tracing wires from one point to another in the unit.

Semiconductor Lead Configuration. The lead configurations of the semiconductor devices used in this instrument are shown in Fig. 4-1.

Multi-Pin Connector Identification. Multi-pin connectors (also called "harmonicas") mate with groups of pins soldered to circuit boards. Pin number 1 is indexed with a triangular mark on the circuit board and molded on the holder of the multi-pin connector, as shown in Fig. 4-2. Each group of pins is identified by its corresponding J or P number etched on the circuit board. The J and P numbers on the circuit boards correspond to the J and P component numbers on the schematic diagrams.

Rear Interface Connector Pin Locations. The 7A16P PROGRAMMING-LOGIC board couples the plug-in to the associated mainframe. Figure 4-3 identifies the pins on the interface connector as shown on the schematic diagrams.

NOTE
LEAD CONFIGURATIONS AND CASE STYLES ARE TYPICAL, BUT MAY VARY DUE TO VENDOR CHANGES OR INSTRUMENT MODIFICATIONS.



SIGNAL DIODE



LIGHT EMITTING DIODE (L.E.D.)

SINGLE



DUAL

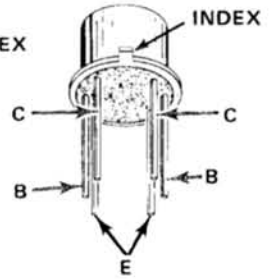

METAL CASE TRANSISTORS

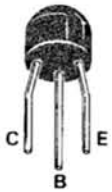

PLASTIC CASE TRANSISTORS



PLASTIC CASE FETS

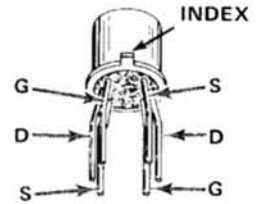

DUAL METAL CASE FET

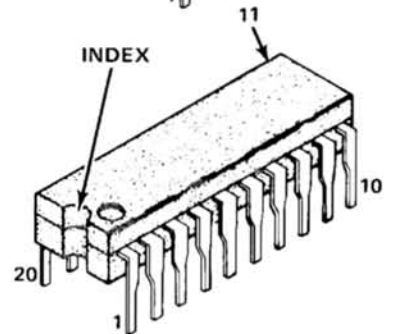
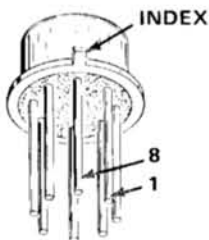
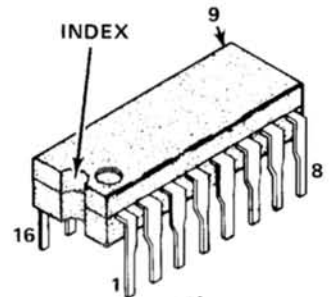
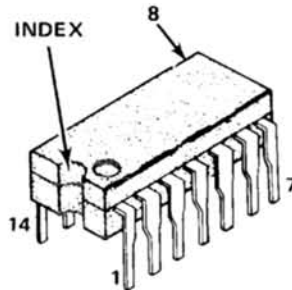
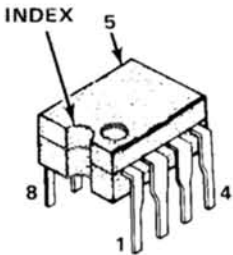

INTEGRATED CIRCUITS

1986-66A

Fig. 4-1. Semiconductor lead configurations.

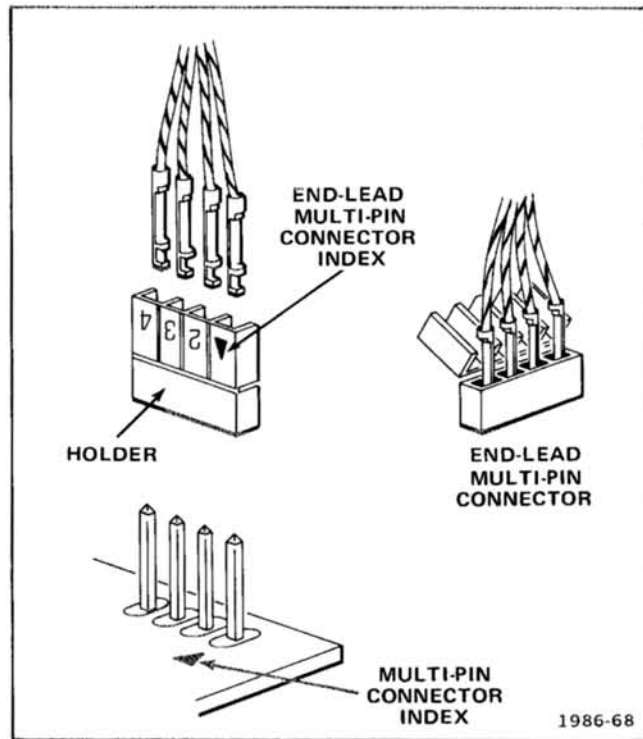

Fig. 4-2. End-lead multi-pin connector assembly.

Troubleshooting Equipment

The following equipment is useful for troubleshooting the 7A16P:

1) **Semiconductor Tester** -- Some means of testing the transistors, operational amplifiers, comparitors, diodes, and FET's used in this instrument is helpful. A transistor-curve tracer such as the TEKTRONIX Type 577-177 or 577-178 will give the most complete information.

2) **Multimeter** -- A voltmeter is required for checking voltages within the circuits, and an ohmmeter for checking resistors and diodes. The voltmeter should have a 10 megohm input impedance, a range of at least 0 to 50 volts dc, and an accuracy of 0.1%. The ohmmeter should have a range of 0 to 20 megohms.

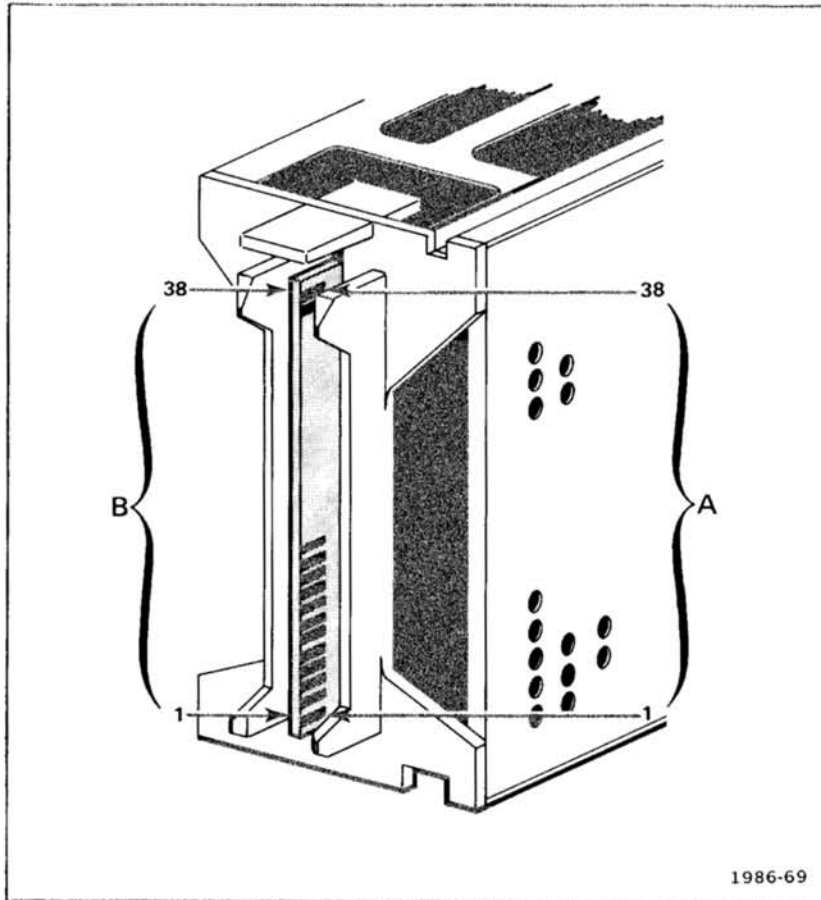

Fig. 4-3. Location of pin numbers on rear interface connector.

3) **Test Oscilloscope** -- A test oscilloscope is required to view waveforms at different points in the circuit. A TEKTRONIX 7000-series Oscilloscope equipped with a readout system, a 7D13 Digital Multimeter unit, a 7B-series Time-Base unit, and a 7A-series Amplifier unit with a 10X probe will meet the needs of both items 2 and 3.

4) **Plug-in Extender** -- This fixture permits operation of the 7A16P outside of the plug-in compartment for better accessibility during troubleshooting. Order TEKTRONIX Part Number 067-0589-00.

Troubleshooting Procedure

This troubleshooting procedure is arranged in an order which checks the simple trouble sources before proceeding with extensive troubleshooting. The first few checks ensure proper connection, operation, and adjustment. If the trouble is not located by these checks, the remaining steps aid in locating the component. When the defective component is located, it should be replaced using the replacement procedure given under **Corrective Maintenance**.

- 1) **Check Control Settings.** An incorrect setting of the 7A16P controls can indicate a problem that does not exist. If there is any question about the correct function or operation of a control or front-panel connector, refer to the operating instructions provided in Section 2.
- 2) **Check Associated Equipment.** Before proceeding with troubleshooting of the 7A16P, check that the equipment used with this unit is operating correctly. If possible, substitute an amplifier unit known to be operating correctly into the mainframe and see if the problem persists. Check that the input signals are properly connected and that the interconnecting cables are not defective.
- 3) **Visual Check.** Visually check the portion of the instrument in which the trouble is suspected. Many problems can be located by visual indications such as unsoldered connections, broken wires, damaged circuit boards, damaged components, or components bent over and touching.
- 4) **Check Instrument Performance.** Check the adjustment of the unit or the affected circuit by performing the performance check in Section 6. The apparent trouble may only be a result of mis-adjustment, and may be corrected by calibration. Complete calibration instructions are given in Section 6.
- 5) **Check Voltages.** Sometimes a circuit stage may not be operating due to incorrect supply voltages. Typical supply voltages are given on the diagrams; however, these are not absolute and may vary slightly between instruments.
- 6) **Trace the Signal.** The amplifier portion of the circuitry can be checked by injecting a signal at the 7A16P input and tracing the signal

7A16P INSTRUCTION

from input to output with an oscilloscope. By noting where the signal disappears or distorts, the source of trouble can be located.

7) **Check Individual Components.** The following methods are provided for checking the individual components. Components which are soldered in place can sometimes be checked by disconnecting one end to isolate the measurement from the effects of surrounding circuitry.

NOTE

To locate intermittent or temperature sensitive components mounted on the attenuator board, Quik Freeze (Miller Stephenson, MS-240, TEKTRONIX Part Number 006-0173-01) is recommended. Dry ice or dichloro-difluoromethane (Freon 12, Dupont or Can-O-Gas) may also be used. Other types of circuit coolant may damage the polysulphone attenuator board.

A) **TRANSISTORS.** The best check of transistor operation is actual performance under operating conditions. Transistors that are soldered to the circuit board should first be checked in-circuit using a dynamic transistor tester; then a replacement can be substituted to further verify that the old transistor is bad. Socketed transistors can immediately be checked by substituting a component known to be good; however, be sure that circuit conditions are not such that a replacement might also be damaged. If substitute transistors are not available, check the old transistor out-of-circuit using a dynamic tester (such as TEKTRONIX Type 577-177). Static-type testers may be used, but since they do not check operation under simulated operating conditions, some defects may go unnoticed. Be sure the power is off before attempting to remove or replace any transistor.

B) **INTEGRATED CIRCUITS.** Analog IC's such as comparitors and operational amplifiers can usually be checked in-circuit with a voltmeter or test oscilloscope. An understanding of the device and circuit operation is essential for this type of troubleshooting. (For example, an op amp can be tested by measuring the input and output circuit voltages and comparing this ratio to the ratio of input and feedback resistors.)

7A16P INSTRUCTION

Analog IC's that are socketed can also be checked out-of-circuit using a dynamic testor such as the TEKTRONIX 577-178.

Digital IC's are best checked in-circuit using a logic probe or voltmeter. Use care when checking voltages and waveforms around DIP (Dual-Inline-Package) IC's so that adjacent leads are not shorted together. A convenient means of connecting a test probe to 14- and 16-pins IC's is with an IC test clip. This device also doubles as an extraction tool.

C) DIODES. A diode can be checked for an open or shorted condition by measuring the resistance between terminals with an ohmmeter set to the R X 1k scale. The diode resistance should be very high in one direction and very low when the meter leads are reversed.

CAUTION

Do not use an ohmmeter scale that has a high internal current. High currents may damage the diodes under test.

D) RESISTORS. Check resistors with an ohmmeter. Resistor tolerance is given in the **Electrical Parts List**. Resistors normally do not need to be replaced unless the measured value varies widely from the specified value.

E) CAPACITORS. A leaky or shorted capacitor can be detected by checking resistance with an ohmmeter on the highest scale. Use an ohmmeter that will not exceed the voltage rating of the capacitor. (Be careful to observe correct polarity when checking electrolytic capacitors.) The resistance reading should be high after initial charge of the capacitor. An open capacitor can best be detected with a capacitance meter, or by checking whether the capacitor passes AC signals.

7) **Repair and Readjust the Circuit.** Special techniques required to replace components in this unit are given under **Component Replacement**. Be sure to check the performance of any circuit that has been repaired or that has had any electrical components replaced. Recalibration of the affected circuit may be necessary.

Specific Troubleshooting Information

The following information provides an aid to troubleshooting parts of the analog circuitry and the microprocessor system. Before troubleshooting the instrument, an understanding of the circuit operation is required. Refer to the Circuit Description for a discussion of the circuit operation.

Microprocessor System. If the 7A16P fails to power-up in the correct state, the following procedure provides an aid to locating the fault without special microprocessor service equipment.

1) Measure all the supply voltages. If they are out of tolerance, the power-up circuit in the plug-in will not initialize the microprocessor system correctly. Check for faults in the plug-in. If none are found, check the mainframe power supplies.

2) Temporarily remove the $\overline{\text{STOP}}$ strap, P1420, on the PROGRAMMING LOGIC board. Press any front panel button (except VARIABLE) to cause an interrupt and start the MPU clock. Be sure to replace the $\overline{\text{STOP}}$ strap when you are through troubleshooting the clock circuit.

3) Check for valid two-phase clock signals at TP626 (Phase 1) and TP726 (Phase 2). Refer to the Calibration Procedure for a discussion of the MPU clock adjustment. If the clock signals are present, go to step eight.

4) Check that the clock jumper straps are correctly placed on the corresponding square pins.

5) Check the output (pin 11) of U600D. This pin should be high (+2.4 to 5.0 volts). If it is not, check the flip-flop formed by U620D and U700A. The $\overline{\text{STOP}}$ line (pin 12 of U610D) should be high.

6) Check pin 5 of U700A. If this pin is low, there is a fault in the power-up circuit (assuming the supply voltages are correct).

7A16P INSTRUCTION

7) If no faults are found in steps four through six, there is a fault in the clock circuit.

8) Check pin 40 of U920 ($\overline{\text{MPURES}}$) and pin 34 of U900 ($\overline{\text{POR}}$). If either of these lines is low, there is a fault in the power-up circuit.

9) Momentarily short pin 34 of U900 to ground. If the plug-in powers-up correctly, there is a fault in the power-up circuit.

10) Check that pin 2 of U920 is high and pin 39 is low.

11) Check that pins 36 and 37 of U920 are tied together.

12) If these tests fail to identify the fault, troubleshooting with a microprocessor debugging aid (such as a Tektronix 8000-series microprocessor lab) may be necessary.

Self Test Addresses. If the 7A16P fails to power-up and the above steps fail to identify the problem, the MPU may have detected a fault while performing the self-test routines. If a fault is detected, the MPU "hangs" at a specified address. The fault can be determined by measuring the state of address bus lines (A0-A11) with a DVM or logic analyzer (such as the Tektronix 7D01). Table 4-1 shows the addresses and the fault(s) detected by the MPU for each address. If a fault is indicated in the ROM, RAM or PIA's, replace the involved components and see if the problem is cured.

TABLE 4-1

7A16P Self Test Hang Addresses

- 78B6₁₆ - The RAM was filled with ones. Data was read back and complemented, and a non-zero byte was found. The RAM is left filled with zeros.
- 78C7₁₆ - Any ones left from the previous test hangs the 6800 here.
- 78E6₁₆ - The RAM failed a pattern-sensitivity test.
- 790B₁₆ - The PIA control registers were filled with zeroes. The registers were read back and a one was found.
- 792E₁₆ - The PIA registers failed a read/write test.
- 7955₁₆ - The high-level ROM (U830) failed a checksum test.
- 7961₁₆ - The low-level ROM (U630) failed a checksum test.

Corrective Maintenance

Corrective maintenance consists of component replacement and instrument repair. Special techniques required to replace components in this unit are given here.

Obtaining Replacement Parts

Standard Parts. All electrical and mechanical part replacements for the 7A16P can be obtained through your local Tektronix Field Office or representative. However, many of the electronic components can be obtained locally in less time than is required to order them from Tektronix, Inc. Before purchasing or ordering replacement parts, check the parts list for value, tolerance, rating, and description. The vendor's or manufacturer's part number and address are also provided in the parts list.

NOTE

When selecting replacement parts, it is important to remember that the physical size and shape of a component may affect the performance of the instrument, particularly at high frequencies. All replacement parts should be direct replacements unless it is known that a different component will not adversely affect instrument performance.

Order all special parts directly from your local Tektronix Field Office or representative.

Ordering Parts. When ordering replacement parts from Tektronix, Inc., include the following information:

- 1) Instrument Type.
- 2) Instrument Serial Number.

7A16P INSTRUCTION

3) A description of the part (if electrical, include circuit number found in the Replaceable Electrical Parts list--Section 7).

CKT NUMBERING EXAMPLE:

R162 on A12 Assembly = R12162 in Parts List
└──┬──┘
 └── Assembly Number

4) TEKTRONIX Part Number.

Soldering Techniques

WARNING

Disconnect the instrument from the power source before soldering.

Attenuator Circuit Board. The Attenuator Circuit Board is made from fire-retardent polysulphone. Use extreme care when cleaning or soldering this material. The following rules should be observed when removing or replacing parts:

- 1) Use a low-wattage soldering iron (not over 15 watts).
- 2) Do not apply more heat, or apply heat for a longer time, than is absolutely necessary.
- 3) Use some form of vacuum solder-remover when removing multi-lead devices. (On most IC's, it is best just to cut the leads.)
- 4) Do not apply any solvent containing ketones, esters, or halogenated hydrocarbons.
- 5) To clean, use only water-soluble detergents, ethyl, methyl or isopropyl alcohol.

Special caution must also be exercised when soldering or unsoldering the reed switches on the attenuator board. Damage can be caused by:

7A16P INSTRUCTION

- 1) Bending a lead near the glass reed enclosure
- 2) Pulling or pushing on the lead.
- 3) Excessive heating of the lead.

When soldering, use the least time and temperature required to do the job.

Circuit Boards (except Attenuator board). The components mounted on the circuit boards in the 7A16P can be replaced using normal circuit board soldering techniques. Keep the following points in mind when soldering on the circuit boards:

- 1) Use a pencil-type soldering iron with a wattage rating from 15 to 50 watts.
- 2) Apply heat from the soldering iron to the junction between the component and the circuit board.
- 3) Heat-sink the lead to the component by means of a pair of long-nose pliers.
- 4) Avoid excessive heating of the junction with the circuit board, as this could separate the circuit board wiring from the base material.
- 5) Use electronic grade 60-40 tin lead solder.
- 6) Clip off any excess lead length extending beyond the circuit board. Clean off any residual flux with a flux-removing solvent (note solvent precautions).

Metal Terminals. When soldering metal terminals (potentiometers, etc.) use 60-40 tin-lead solder and a 15 to 50 watt soldering iron. Observe the following precautions when soldering metal terminals:

- 1) Apply only enough heat to make the solder flow freely.
- 2) Apply only enough solder to form a solid connection. Excess solder may impair the function of the part.

7A16P INSTRUCTION

3) If a wire extends beyond the solder joint, clip off the excess.

4) Clean the flux from the solder joint with a flux-removing solvent.

Component Replacement

WARNING

Disconnect the equipment from the power source before replacing components.

Semiconductor Replacement. Some transistors in the 7A16P are socketed. These should not be replaced unless actually defective. If removed from their sockets during routine maintenance, return them to their original sockets. Unnecessary replacement of transistors may affect the calibration of the instrument. When transistors are replaced, check the performance of any part of the instrument that may be affected.

Replacement semiconductors should be of the original type or a direct replacement. The schematic diagram shows the lead configurations of the semiconductors used in this instrument. If the replacement semiconductor is not of the original type, check the manufacturer's basing diagram for proper basing.

Front-Panel LED's. When replacing any front-panel LED's (Light Emitting Diodes), be sure to place the new one(s) in the same exact alignment with the other LED's to facilitate reassembly of the front panel. When soldering LED's, use the minimum heat required to do the job.

Free-Standing Components. When replacing any components that are free-standing (not directly mounted to circuit boards), be sure to place the new components in the same physical location and position as the old components. If this is not done, the high-frequency characteristics of the plug-in may be altered; also, there may be a possibility of components touching and causing a short circuit.

Circuit Board Removal

The 7A16P contains the following circuit boards:

- 1) LED board
- 2) SWITCH board
- 3) ATTENUATOR board
- 4) ACTUATOR board
- 5) AMPLIFIER board
- 6) SHIELD board
- 7) PROGRAMMING-LOGIC board

The LED and SWITCH boards are attached to the front-panel casting. The ATTENUATOR and ACTUATOR boards are enclosed in a metal case, hereafter referred to as the input attenuator housing. The AMPLIFIER, SHIELD, and PROGRAMMING-LOGIC boards are all connected together via mounting studs and multi-pin (interboard) connectors. These three boards are held to the plug-in frame via special fastening nuts that hold the PROGRAMMING-LOGIC board to the top and bottom plug-in rails. (The SHIELD board simply insulates and shields the AMPLIFIER and PROGRAMMING-LOGIC boards; there are no components mounted on it.)

In general, the AMPLIFIER and PROGRAMMING-LOGIC boards will rarely need removal since most of their components are readily accessible and easily replaced. The LED and SWITCH boards will need removal when replacing front-panel components such as the Light Emitting Diodes (LEDs). Similarly, it will usually be necessary to remove the ATTENUATOR and ACTUATOR boards before troubleshooting or replacing any of their components.

The following procedure explains how to remove each of these boards from the plug-in. Performing all of these steps in the order listed will result in a complete disassembly of the 7A16P. To reassemble the plug-in, reverse the process of disassembly. (The exploded-view diagrams in Section 9 aid in assembling the plug-in.)

7A16P INSTRUCTION

A) Removal of LED and SWITCH Boards

- 1) Remove the front-panel POSITION control knob by loosening the Allen set-screw.
- 2) Remove the tension spring from the end of the plug-in pull latch (inscribed with the word "7A16P").
- 3) Dismount the front-panel cover plate by gently prying on the bottom with a regular screw driver.
- 4) Remove the two flathead Phillips screws located between the two BNC INPUT connectors.
- 5) Remove the four Phillips screws (one from each corner) of the front-panel casting.
- 6) Remove side panel from right side of the plug-in.
- 7) Loosen the Allen-set screw in the VARIABLE shaft coupling; then remove the VARIABLE control knob and shaft.
- 8) Gently rock the front-panel casting to remove the front-panel assembly from the edge connector on the PROGRAMMING-LOGIC board.
- 9) With the front-panel assembly removed, dismount the LED board by removing all five Phillips screws.
- 10) Carefully separate the LED board from the SWITCH board.

B) Removal of ATTENUATOR and ACTUATOR Boards

- 1) Remove side panel from left side of plug-in.
- 2) Unsolder the two leads of transformer T418 that connect to the AMPLIFIER board, being careful not to overheat integrated circuit U540.
- 3) Remove ribbon connector harmonicas P630, P632, and P730 from

7A16P INSTRUCTION

their pins on the AMPLIFIER board.

- 4) Remove the Phillips screw at the end of the ATTENUATOR board that attaches to the AMPLIFIER board.
- 5) If the front panel has not been previously removed, perform steps 1 through 4 under procedure A so that the input attenuator assembly can be removed from the plug-in.
- 6) With the attenuator assembly removed from the plug-in, unscrew the three flathead Phillips screws that hold the cover plate of the attenuator housing.
- 7) Remove the three roundhead Phillips screws on the opposite side of the attenuator housing.
- 8) Unsolder the two input leads from the BNC connectors. Be very careful not to break the reed switches.
- 9) Pull the ATTENUATOR-ACTUATOR boards back from the BNC connectors to allow room to unsolder the two remaining leads from these connectors. Then unsolder these leads where they connect to the BNC connectors.
- 10) Remove the three roundhead Phillips screws that hold the ATTENUATOR board to the ACTUATOR board.
- 11) Carefully separate the ATTENUATOR board from the ACTUATOR board.

C. Removal of AMPLIFIER, SHIELD, and PROGRAMMING-LOGIC Boards

- 1) If the input attenuator assembly has not been previously removed, perform steps 1 through 5 of procedure B.
- 2) Unfasten coax connectors J20, J25, J38, and J40 from the AMPLIFIER board. Do not remove the connectors on the other ends of the coax jumpers.
- 3) Loosen the four roundhead Phillips screws from the studs

7A16P INSTRUCTION

connecting the AMPLIFIER board to the PROGRAMMING-LOGIC board.

- 4) Carefully lift the AMPLIFIER board from the SHIELD and PROGRAMMING-LOGIC boards. Use a gentle prying motion to separate the multi-pin (interboard) connectors.
- 5) Remove the 7A16P Rear Interface panel by unscrewing the four roundhead Phillips screws (one at each corner).
- 6) Remove the screws from the two fasteners that hold the PROGRAMMING-LOGIC board to the top and bottom plug-in rails; pull the board back from the front-panel edge-connector socket if the front panel has not been removed already.
- 7) To separate the SHIELD board from the AMPLIFIER board, remove the spring retainers from the mounting studs on the AMPLIFIER board.

Recalibration After Repair

After any electrical component has been replaced, the calibration of that particular circuit should be checked, as well as the calibration of other closely related circuits. Refer to Section 6 for these procedures.

Repackaging for Shipment

If the 7A16P is to be shipped to a Tektronix Service Center for service or repair, attach a tag showing: owner (with address) and the name of an individual at your firm that can be contacted, complete instrument serial number, and a description of the service required.

Save and re-use the package in which your unit was shipped. If the original packaging is unfit for use or not available, repackage the instrument as follows:

- 1) Obtain a carton of corrugated cardboard having inside dimensions of not less than six inches more than the instrument dimensions; this will allow for cushioning.

7A16P INSTRUCTION

2) Surround the unit with polyethylene sheeting to protect the finish of the instrument.

3) Cushion the instrument on all sides by tightly packing dunnage or urethane foam between the carton and the plug-in unit, allowing three inches on all sides.

4) Seal the carton with shipping tape or an industrial stapler.

The carton test strength for your instrument is 200 pounds.

SECTION 5

Circuit Description

Introduction

This section describes the 7A16P block diagram and circuit operation in detail. Frequent reference is made to the schematic diagrams at the rear of the manual. Each fold-out schematic is tabbed and numbered for ease of use. As you go through the following circuit descriptions, unfold the appropriate schematics and refer to them as needed.

Block Diagram

Before we begin the detailed circuit descriptions, we will discuss the block diagram shown in Fig. 5-1.

The input signal is applied to the attenuator through one of the INPUT BNC connectors on the front panel. Precision attenuators are switched into the signal path to select the desired attenuation factor. The amplifier provides for selecting normal or inverted signal polarity and a X1 or X2 attenuation. The positioning circuit adds a DC current to the signal for positioning. A final amplifier stage splits the signal into separate display and trigger signals of equal amplitude.

The 7A16P attenuator, front panel and IEEE 488 (commonly referred to as GPIB-General Purpose Interface Bus) interface are controlled by a microprocessor system in the plug-in. The heart of this system is a Motorola M6800 Microprocessing Unit (MPU). A control program, resident in 4K (1K= 1024) bytes of Read Only Memory (ROM), directs the MPU activity. The MPU uses 128 bytes of Random Access Memory (RAM) as a "scratch pad".

Three Peripheral Interface Adapters (PIA's) handle internal communication between the MPU and the other circuits in the plug-in. The switching logic drives the attenuator and front panel LED's (Light Emitting Diodes). The GPIB interface controls the handshaking on the IEEE 488 bus.

7A16P INSTRUCTION

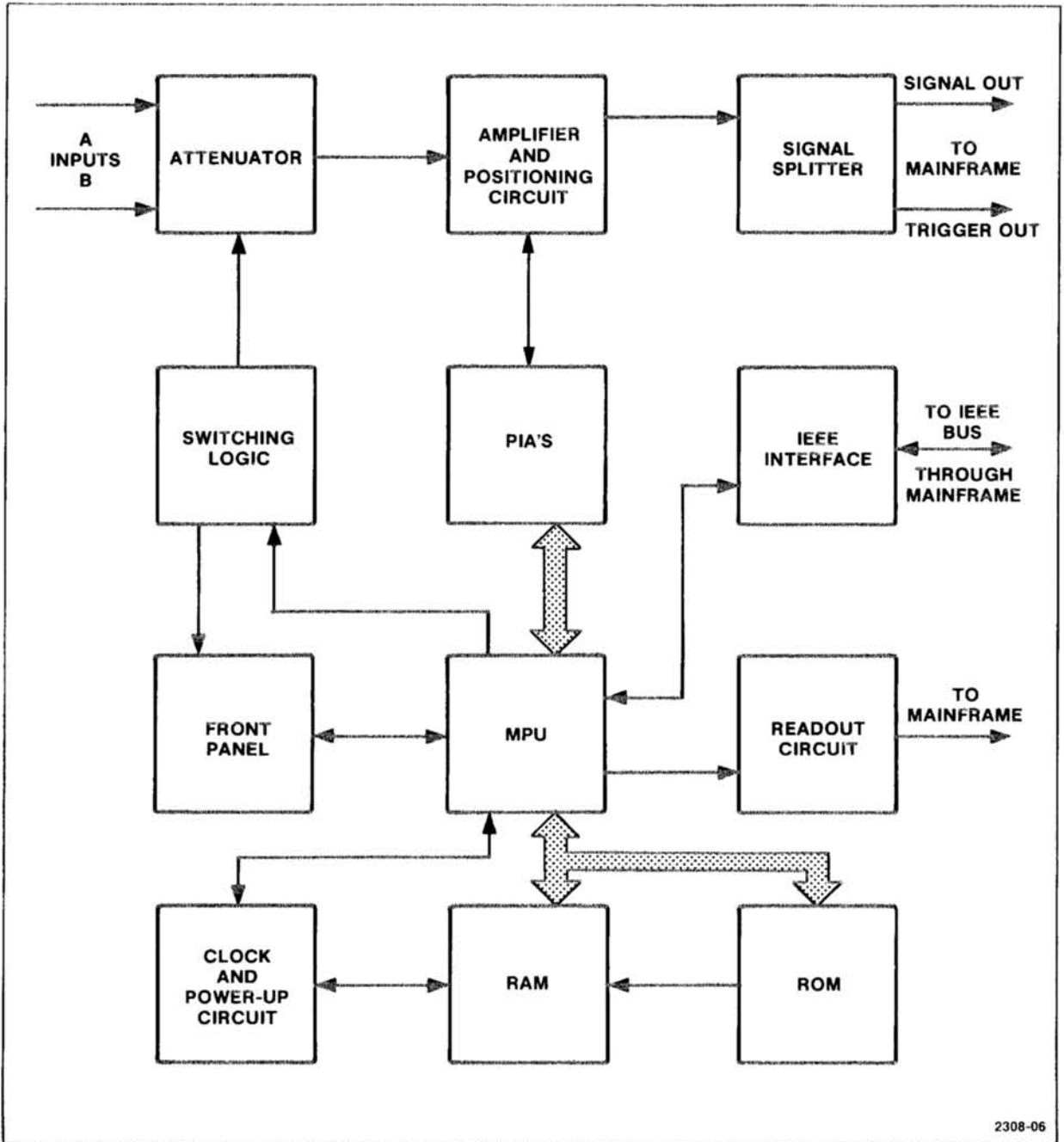

Fig. 5-1. 7A16P Block Diagram

7A16P INSTRUCTION

The clock circuit generates the 2-phase clock signal required by the MPU. When power-up occurs, the power-up circuit initializes the MPU and PIA's and starts the clock. The readout circuit encodes the attenuator settings and sends the readout information to the mainframe.

Attenuator

The Attenuator (Diagram 1) consists of the input selection and coupling circuit, two X10 precision attenuators, a buffer amplifier and a selectable X2 or X5 low-impedance attenuator.

Input and Coupling Circuit. The input signal comes in on the A or B INPUT BNC connectors (upper-left of schematic 1). Control signals, generated by the microprocessor, activate reed switch coils K000 or K010, closing S000 or S010. These switches select the A or B connector as input to the plug-in. C007 and LR007 keep the Voltage Standing-Wave Ratio (VSWR) on the input low. If the 50-ohm input impedance is selected, the microprocessor activates K004, closing S004 and connecting R012, R010, R002, and R004 from the signal line to ground. The parallel combination of these resistors appears as a 50-ohm impedance to the input. When S004 is open, the input impedance is 1 megohm. If DC coupling is selected, S002 closes, shorting C008 with R000. For AC coupling S002 is open, so C008 is in series with the signal path.

X10 Attenuators. The microprocessor switches the attenuators in or out of the signal path to set up the attenuation factors required for each VOLTS/DIV setting. Table 5-1 shows the attenuator configurations for each VOLTS/DIV setting.

TABLE 5-1

Attenuator Configurations

VOLTS/DIV Setting	Attenuator Stages				Gain Stage
	AT112 X10	AT212 X10	X2*	X5*	X2**
10 mV.	OUT	OUT	IN	OUT	OUT
20 mV.	OUT	OUT	IN	OUT	IN
50 mV.	OUT	OUT	OUT	IN	IN
100 mV.	IN	OUT	IN	OUT	OUT
200 mV.	IN	OUT	IN	OUT	IN
500 mV.	IN	OUT	OUT	IN	IN
1 V.	IN	IN	IN	OUT	OUT
2 V.	IN	IN	IN	OUT	IN
5 V.	IN	IN	OUT	IN	IN

OUT Indicates the attenuator stage is bypassed (out of the circuit)

IN Indicates the attenuator is in the circuit

* These attenuators are part of the low impedance attenuator

** This is the X2 gain stage of the amplifier

The X10 attenuators are frequency-compensated voltage dividers that are primarily resistive at low frequencies. At high frequencies they are primarily capacitive dividers. Each attenuator contains an adjustable series capacitor to provide correct attenuation at high frequencies and an adjustable shunt capacitance to provide a constant input capacitance. As a result, these attenuators provide a constant attenuation factor and input characteristic throughout the bandwidth of the instrument.

The first attenuator (AT112) is switched by S100, S110 and Q100. In all ranges except 10 mV/DIV, 20 mV/DIV, and 50 mV/DIV, S110 is closed, S100 is open and Q100 is on. This puts AT112 in series with the signal path. For other settings of VOLTS/DIV, S110 is open, S100 is closed and Q100 is off, providing a signal path around AT112.

The second attenuator (AT212) is switched into the signal path for the 1V/DIV, 2V/DIV and 5V/DIV settings (see Table 5-1). The switching circuit is similar to the first attenuator, except that Field Effect

7A16P INSTRUCTION

Transistors (FET's) are used in place of reed switches. Large resistances in series with the control lines isolate the logic circuits from the FET gate capacitance. Since the FET's are floated on large resistances, they can pass very little current to ground, and the circuit can withstand large overload voltages. The diodes in the control lines (CR116 and CR106) limit the current into the FET circuitry.

When AT212 is unselected, the drain-to-source capacitance of Q200 could couple AT212 into the circuit, degrading high frequency response. Q110 shunts the input of the attenuator with a capacitor when AT212 is unselected. This prevents the capacitance of Q200 from coupling AT212 into the circuit.

Buffer Amplifier. The output signal from the X10 Attenuator network appears at the top of R204. High frequencies are coupled through C207 to a unity gain amplifier, Q302. VR303 provides a bootstrapped, positive bias voltage for the gate of Q302. Q303 protects Q302 from overloads.

Low frequencies, including correction for Q302's drift, are fed to the inverting input of U310. U310's output is inverted again by Q300 so the signal at its collector is in phase with the output of Q302. The sum of the output signals is coupled through emitter-follower Q304 to the low impedance attenuator. A part of the output signal is fed back through R307 to U310. C202 sets the roll-off characteristic of U310. R315 and R412 provide nulling for U310's input current and offset voltage.

Low Impedance Attenuator. Q306, Q308, Q400, Q402 and the associated components at the bottom of schematic 1 form a selectable X2 or X5 attenuator. When the X5 attenuation factor is selected (see Table 5-1), Q306 and Q402 are on and Q308 and Q400 are off. As a result, R404, R406, R407 and R400 form a X5 voltage divider. L408 is a "peaking" coil to improve high frequency response. When Q308 and Q400 are on, Q306 and Q402 are off and the divider is configured to provide a X2 attenuation factor.

The output of the attenuator is coupled to the amplifier stages through T418. This transformer keeps shifts in the attenuator ground level from being coupled into the amplifier by making the shifts appear as a common-mode signal at the inputs of the amplifier. R414 provides DC balance for the amplifier inputs.

Amplifier

The amplifier (Schematic 2) consists of the polarity amplifier, the 2X gain amplifier, an additional gain stage, the positioning circuit, the signal splitter and the bandwidth limiting circuit. Several R-C peaking networks throughout the amplifier are used to maintain good high frequency response. We will not discuss these networks in detail, but refer to them in general where they are used.

Polarity Amplifier. The output signal from the attenuator is fed to the inputs of a paraphase amplifier, U540. The outputs of U540 are cross-connected, but only one half of the amplifier is active at any time. The +UP and INV signals, generated by the microprocessor, control which half of the amplifier is active. When normal polarity is selected, +UP is high and the corresponding output transistor pair (collectors on pin 6 and 8) is enabled. As a result, the signal is applied without inversion to U440. If INVERTED polarity is selected, INV is high and +UP is low. The corresponding output pair (pins 5 and 9) is enabled so the signal is inverted and applied to U440.

The network on pins 2 and 3 of U540 provides high frequency peaking. R540, L540 and C532 are also used for peaking high frequency response. R530 and R532 provide a negative bias voltage for the substrate of U540.

2X Gain Amplifier. The output of the polarity amplifier is fed to a gain switching amplifier, U440. The gain of this stage is switched by two control lines from the microprocessor. In the 10mV/DIV, 100mV/DIV and 1V/DIV ranges, the control line coming from Q702 (top-center of schematic 2) goes high. Current flows through R454, into pin 11 and through the right diode at the bottom of U440. The voltage across this forward-biased diode enables the output pair at pins 6 and 8. These pins are tied directly to the next stage, providing full drive to U340.

In other VOLTS/DIV ranges, the control signal coming from Q900 goes high and current flows through R458 and R456, enabling the output pair at pins 5 and 9 of U440. The other pair (pins 6 and 8) still receives some bias current through R359 and R454. The signal current from the input transistors in U440 divides equally between the emitters of the output pairs. As a result, the output current at pins 6 and 8 is reduced by one-half and the signal is attenuated by a factor of two.

7A16P INSTRUCTION

CR338 and R452 provide current to U340's bias network to keep the DC bias level at the inputs constant in the normal and 2X modes.

R458 sets the 2X gain and R446 sets the overall gain. The network on pins 2 and 3 sets the low frequency response and balance. It also provides high frequency peaking.

Gain Amplifier. U340 is the same type of amplifier as previously described in the Polarity Amplifier section. The outputs of U340 are cross-connected so that the in-phase and out-of-phase signals are mixed. The stage gain is set by adjusting the ratio of the in-phase and out-of-phase signals, which is determined by the ratio of currents in the control inputs (pins 11 and 12) of U340.

Now refer to schematic 4. When the VARIABLE control is set to CAL (VARIABLE knob pushed in, and VAR OFF under program control), the output of U600A (bottom-center of schematic 4) is high. As a result, the output of U410B is low and Q408 is on. In this mode, Q408 supplies current to R300 which sets the ratio of the control currents and the stage gain, as just discussed. R300 is set during calibration for a fixed value.

If the amplifier is set for VARIABLE gain (VARIABLE knob out, or VAR ON under program control), the output of U600A is low, so Q308 is on. Now the VARIABLE control, R200, sets the current ratio and stage gain.

R318 (schematic 2) provides DC balance over the range of the variable control. RT238 compensates for temperature variations. C336 and R332 provide for high frequency peaking.

Positioning Circuit. Q214 and the associated components add a DC level to the signal for positioning. The positioning level comes from a 10-bit Digital to Analog Converter (DAC) shown in the upper-left corner of schematic 4. The output of the DAC is proportional to the value of the 10-bit input word from the microprocessor. This 10-bit word can be set from the front panel POSITION control or under program control. We will discuss the operation of this circuit in more detail later. Looking back to the left edge of schematic 2, R304 sets the gain of the position circuit and R302 sets the position centering.

Many Tektronix probes have an IDENTify button that causes the trace to deflect so that it can be identified in a multiple-trace display.

7A16P INSTRUCTION

When the IDENTify button on the probe is pressed, a DC current is added to the signal to deflect its position slightly. If input A is selected, INPA is low (bottom center of schematic 5). The output of U210D is high and Q400 is on. The IDENTify button on the probe connects the outer ring of the input BNC connector (left-center of schematic 1) to ground. As a result, the collector of Q400 goes low. The output of comparator U120A goes low and the output of U410D goes high, causing Q320 to conduct more current (left-center of schematic 2). The additional current through Q320 is added to the signal, causing the trace to deflect. The IDEN line also goes to the readout circuit, shown at the right edge of schematic 6. When IDEN is asserted, the normal readout information is replaced by the word IDENTIFY.

Signal Splitter. The signal and positioning currents are fed to U240. The two differential outputs of U240 are connected to separate common-base transistor amplifiers to generate separate display and trigger signals. U240's control inputs are supplied equal currents through R250 and R252 so the display and trigger signals are equal.

C232 and R138 are high frequency peaking adjustments. R136 adjusts low frequency response.

As the signal travels through the previous stages, some common-mode DC level is added to the signal. The common-base transistor amplifiers shift this DC level back to zero without affecting the differential DC positioning level. If the full bandwidth is selected, BWF is asserted and the output of U710E (bottom-center of schematic 2) is low. The output of U810E is low, so Q140, Q142, Q110 and Q112 are on. As a result, the display and trigger signals are passed to the output without bandwidth limiting.

When limited bandwidth is selected, BWF is low and Q132, Q144, Q100 and Q114 are on. The filter circuits in the collectors of these transistors limit the bandwidth of the display and trigger signals to 20 MHz. CR032, CR046, CR004 and CR014 isolate the bandwidth limiting filter from the circuit when full bandwidth is selected.

The display and trigger output signals are fed to the mainframe through the edge connectors at the rear of the mainframe.

Microprocessor System

We mentioned in the block diagram discussion that the 7A16P is controlled by a microprocessor system in the plug-in. The major components of the system are shown on schematic 3. Full information on the components that comprise the system is given in the Motorola M6800 Microcomputer System Design Data Manual. It will be helpful to have a copy of this manual for reference as you go through the descriptions.

MPU and Memory. The Motorola M6800 (U920) is an 8-bit Micro-processing Unit (MPU). The MPU has a 16-bit address bus (13 bits are used in this system) that allows it to selectively communicate with the memory and PIA's. A separate 8-bit bi-directional bus carries data to and from the MPU.

If an external device asserts the MPU's $\overline{\text{IRQ}}$ (Interrupt ReQuest) or $\overline{\text{NMI}}$ (Non-Maskable Interrupt) inputs, the normal program execution is interrupted. The processor saves its current status, then determines what caused the interrupt and executes an appropriate service routine. These service routines include such tasks as scanning the front panel buttons or getting a byte from the IEEE 488 bus. While servicing the interrupt, the processor can mask its $\overline{\text{IRQ}}$ input so that further interrupts will not be recognized until the current interrupt has been serviced. The $\overline{\text{NMI}}$ input cannot be masked. We'll discuss the interrupt sequence in more detail later.

The program that controls the MPU's activity resides in two 2048x8-bit ROM's (U630 and U830). The ROM's are accessed by asserting an address in the range 7000_{16} - $7FFF_{16}$. The MPU also uses a 128x8-bit RAM (U1030) as a "scratch pad" memory. The RAM occupies addresses from 0 - $7F_{16}$.

PIA's. The processor communicates with other parts of the plug-in and the IEEE bus through three M6820 PIA's (U900, U1000 and U1200). Complete information on these chips is contained in the M6800 Microcomputer System Design Data Manual. We'll discuss only the relevant details here.

Figure 5-2 shows a block diagram of the M6820. Each PIA contains two separate Input/Output (I/O) ports and control registers. Each line of the I/O ports can be programmed as an input or output by setting bits in the data direction registers.

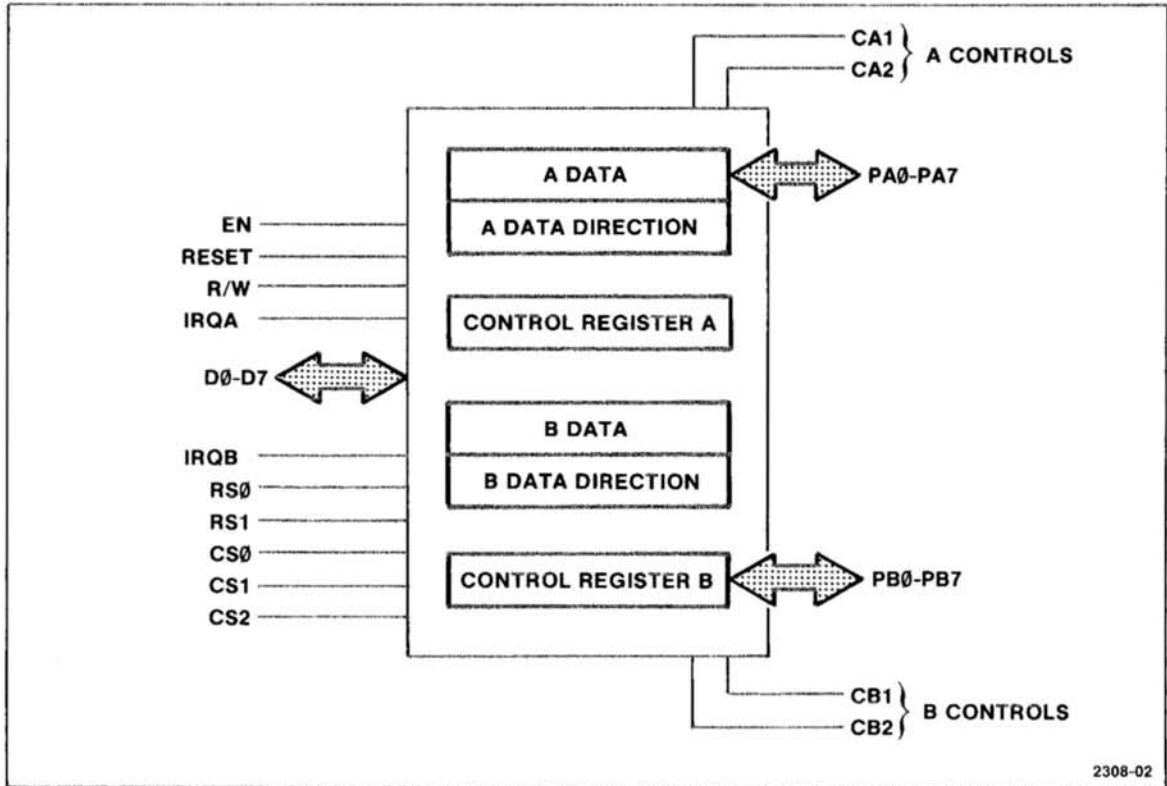

Fig. 5-2. Peripheral Interface Adapter Block Diagram.

Two interrupt outputs (\overline{IRQA} and \overline{IRQB}) signal the processor that the PIA has data or needs service. When an interrupt occurs, a flag is also set in the appropriate control register. Since the interrupt lines are OR-tied to the MPU's \overline{IRQ} input, the processor must read each PIA's control registers to determine which one generated the interrupt.

Power-up Circuit. When power is applied to the plug-in, the power-up circuit monitors the power supplies and generates initialize signals for the MPU, clock circuit, and PIA's. The power-up circuit is located in the lower-left corner of schematic 4.

Comparators U220B, U220C and U220D monitor the +15V, +12V, +5.1V and -5.2V supplies. The outputs of the comparators are OR-tied so that all the supplies must be present before the comparator outputs go high. When they do, C520 begins charging through R420 and R422. When the voltage at the top of R422 reaches about 1.8 volts (about 2 milliseconds after the comparator outputs go high), DS520 becomes forward biased and Q520 turns

7A16P INSTRUCTION

on. As a result, POR (Power-On Reset) and the input of U720A go low. The output of U720B and $\overline{\text{POR}}$ go high. The POR and $\overline{\text{POR}}$ lines initialize the PIA's and assert the TSC (Three-State Control) input on the MPU (Refer to the M6800 manual information on this input).

U610D and U700A form an R-S flip-flop that controls the clock circuit. Since the output of U720A stays low for 2 milliseconds after the power supplies are stable, this flip-flop powers-up with the output of U700A high. The flip flop will stay in this state until $\overline{\text{STOP}}$ is asserted. We'll discuss the $\overline{\text{STOP}}$ line later.

Since pin 6 of U700A is high, when the output of U720A goes high, the output of U600D also goes high. The low-to-high transition fires U1430A and the Q output goes low for about 13 microseconds. Pin 10 of U600C is high so $\overline{\text{MPURES}}$ (MPU RESet) is asserted until U1430A times out. This negative-going pulse forces the MPU into a reset sequence. (Refer to the M6800 manual for specific information on the MPU reset sequence).

Clock Circuit. U420A, U420B and the associated components in the upper-right corner of schematic 4 generate the 2-phase MPU clock signal.

Recall that the output of U600D makes a low-to-high transition shortly after power-up. This transition fires U420B, so its $\overline{\text{Q}}$ output goes low and U420A is cleared. About 500 nanoseconds later, U420B times out and the low-to-high transition on the Q output fires U420A. U420A times out about 500 nanoseconds later and the negative transition on the Q output fires U420B, repeating the process.

The $\overline{\text{Q}}$ outputs of U420A and U420B feed open-collector drivers (U720B and U720D). The outputs of these gates drive phase 1 and phase 2 clock lines. The MPU clock inputs require a shorter rise time than the open-collector drivers can produce with simple pull-up resistors. Q620, Q624 and the associated components form active pull-ups that improve the rise time of the driver outputs. We'll discuss Q620 and the associated circuit as an example.

When the $\overline{\text{Q}}$ output of U420B makes a high-to-low transition, C614 couples the negative going pulse to the base of Q620. As a result, Q620 turns on for a short period and pulls the output of U720D up very quickly. The positive going transition does not affect the circuit since the base of Q620 must go below about 4.5 volts to turn on.

7A16P INSTRUCTION

The R-S flip-flop of U610D and U700A controls the clock generator as previously discussed. When the MPU is idle it asserts 800_{16} on its address bus for about 500 nanoseconds and VMA (Valid Memory Address) goes high (upper left of schematic 3). U1320A and U1320B decode the address and assert \overline{STOP} while the address is on the bus. When \overline{STOP} goes low, the flip-flop is reset and the output of U600D goes low, disabling the clock. The clock remains off until an interrupt occurs (\overline{IRQ} is asserted) or an Interface Clear message is received on the IEEE 488 bus (\overline{IFC} is asserted). Since the MPU is a dynamic device, data is lost if the clock is stopped for more than about 10 microseconds. As a result, when the clock is restarted, a power-on sequence is executed as previously discussed.

Front Panel Buttons. The front panel buttons provide for local control of the 7A16P. Refer to schematic 7 and notice that the front panel buttons are organized in a 4 X 4 matrix. The microprocessor sets the row lines (R0-R3) low so when a button is pressed, one of the column lines (C0-C3) goes low (pull-ups in the PIA hold the lines high when they are open). If any of the column lines go low, the output of U700B (bottom-center of schematic 3) goes low, pulsing the CA1 input. This generates an interrupt to the MPU. When the MPU services the interrupt, it takes all the row lines low, then it sets the row lines high one at a time and reads the column lines to determine which button was pressed. When the button is found, the MPU executes an appropriate service routine.

Switching Logic

The Switching Logic (schematic 5) takes the output signals from the PIA's and drives the Attenuator, Amplifier, Front Panel and Readout control circuitry. In some cases one logic signal from the PIA may control several output lines. We'll look at one example of the logic and driver circuitry - the A or B input selection logic. The other circuits are similar.

If the A input is selected, the MPU asserts \overline{INPA} (through the PIA-U900). The low in \overline{INPA} goes to pin 4 of U610B. If GND is not asserted (the GND button is not pressed or CPL GND is not selected under program control), pin 5 of U610B is also low. As a result, the output of U610B is low and Q722 is on. Current flows through Q722 and K010 (upper-left of schematic 1) is energized. This closes S010 and enables the A input.

7A16P INSTRUCTION

Looking back to schematic 5, since $\overline{\text{INPA}}$ is asserted, the output of U210D is high. Pin 2 and the output of U610A are high, so Q720 is off and input B is not enabled. $\overline{\text{LINPA}}$ is high so the front panel INPUT LED (Light Emitting Diode), DS410 (lower-right of schematic 7) is off, indicating that the A input is selected.

The comparators in the lower right of schematic 5 detect the type of probe that is connected to the selected input. If a Tektronix X10 encoding probe is connected, the outer ring of the BNC input connector is grounded through a resistor in the probe. The value of this resistor is selected to draw enough current through R404 to drop the voltage on pin 7 of U120B below about 3.3 volts. This causes the comparator's output (P010) to switch low. Similarly, if an encoding X100 probe is connected, a lower value of resistance connects the ring to ground and the output of U120C (P100) goes low. If the IDENTify button is pushed, the ring is shorted to ground, and the outputs of U120A, B and C ($\overline{\text{IDEN}}$) switch low. The outputs of these comparators go to the microprocessor and readout circuit to modify the CRT readout and computer V/D? query response.

GPIB Interface

The GPIB Interface handles all communication between the MPU and the IEEE 488 bus. This description assumes a basic understanding of the GPIB protocols. Refer to IEEE STD 488-1975 for a complete discussion of the bus.

Before we discuss the GPIB Interface in detail a review of the handshake process is necessary. The IEEE 488 bus uses a three-wire interlocked handshake to transfer all data bytes. When all the addressed listeners on the bus are ready to receive data, $\overline{\text{NRFD}}$ (Not Ready for Data) goes high. The talker asserts data on DIO0-DIO7 and, when the data is stable, asserts $\overline{\text{DAV}}$ (Data Valid). When all the addressed listeners have accepted the data, $\overline{\text{NDAC}}$ (Not Data Accepted) goes high, and the talker releases $\overline{\text{DAV}}$. This process is repeated for every byte that is transferred on the bus. Refer to Appendix B of the IEEE Standard for a complete discussion and timing diagrams of the handshake process.

IEEE 488 Data Bus. The GPIB data bus (DIO0-DIO7) uses time-slot lines 2 through 9 (TS2-TS9) on the plug-in edge connector as a data bus. These lines are used in non-programmable mainframes for the readout time-slot

7A16P INSTRUCTION

lines. In a programmable mainframe, A24 (upper-left corner of schematic 6) is tied to a line that is clamped to about +3 volts maximum, turning Q1512 on. U1500 expects the modified time-slot information on TS1 and TS10 while TS2-TS9 are enables as the GPIB data bus. We'll discuss the readout system later.

Acceptor Handshake. The 7A16P must "listen" to the data bus whenever it has been addressed ar $\overline{\text{ATN}}$ (Attention) is asserted. When either of these cases are true, the output of U1530C is high, enabling U1530D, U1620B and U1620C. The MPU asserts BUSY (left center of schematic 6) while it is processing a byte from the bus. When BUSY and $\overline{\text{ATN}}$ are not asserted, the output of U1226A is high. The output of U1226B is low when $\overline{\text{DATVAL}}$ (DATA VALid) is unasserted and the output of U1226A is high. $\overline{\text{NRFD}}$ is high (unasserted), indicating that the interface is ready for data, when the output of U1530C is high and the output of U1226B is low. $\overline{\text{NRFD}}$ is asserted (low) if BUSY or $\overline{\text{DATVAL}}$ are asserted, indicating that the MPU is processing a byte or the interface is receiving a byte. When $\overline{\text{ATN}}$ is asserted the plug-in must listen, so $\overline{\text{NRFD}}$ goes high.

With $\overline{\text{NRFD}}$ high (ready for data) the interface is ready for the next step in the handshake process. The talker places data on the bus and, after a settling delay, asserts $\overline{\text{DAV}}$. When $\overline{\text{DAV}}$ goes low the output of U1520D goes high and the clear input of U1630B is released. The MPU asserts $\overline{\text{DATAACC}}$ (DATA ACCEpted) when it has received the byte. On the rising edge of $\overline{\text{DATAACC}}$, U1630B is clocked and the Q output goes low. The low on the input of U1620B causes $\overline{\text{NDAC}}$ to go high. This tells the talker that the data is accepted. Finally, the talker releases $\overline{\text{DAV}}$ and the output of U1520D goes low, clearing U1630B and asserting $\overline{\text{NDAC}}$. If BUSY is asserted, (indicating that the input buffer is full or EOI have been received), it is released when the MPU is ready for more data. This complete the acceptor handshake process.

Source Handshake. The source handshake is not implemented as defined by the IEEE 488 Standard. Instead, the plug-in talks through the mainframe using a non-interlocked handshake. The mainframe then generates the standard three-wire GPIB source handshake and transfers the data to the IEEE 488 bus.

When the 7A16P becomes a talker, TALK (left-center of schematic 6) is asserted. The MPU places its data on the bus and pulses $\overline{\text{SEND}}$ low. If $\overline{\text{ATN}}$ is not asserted, the negative transition on $\overline{\text{SEND}}$ fires one-shot

U1430B. The Q output of U1430B is asserted for about 1 microsecond and the output of U1620A ($\overline{\text{SND}}$) goes low. When U1430B times out, $\overline{\text{SND}}$ goes high and the mainframe latches the data from the plug-in. When the mainframe has complete the transfer, $\overline{\text{DAV}}$ makes a low-to-high transition (recall our discussion of the GPIB handshake process). This transition clocks U1630A and the Q output goes to the current state of $\overline{\text{ATN}}$. If $\overline{\text{ATN}}$ is high (unasserted), SENT goes high, telling the microprocessor that the data transfer is complete. If $\overline{\text{ATN}}$ is asserted during the data transfer, U1430B is cleared and $\overline{\text{BADTLK}}$ is asserted, indicating that the transfer was interrupted.

When the 7A16P is listening, U1500 sources current onto the bus. The mainframe can sink this current and control the bus, but other programmable plug-ins cannot. As a result, when one plug-in is talking, all others must be off the bus (u1500 disabled). U1330C gates $\overline{\text{SND}}$ with the Q output of U1430B. If $\overline{\text{SND}}$ is asserted and the Q output of U1430B is low, another plug-in is talking, so the output of U1330C goes low. The output of U1520F and ENABLE go high disabling U1500.

Readout Circuit

The readout circuit encodes the probe type and attenuator settings and sends the information to the mainframe for display with the signal. Before we begin the detailed circuit description, a review of the basic readout system is necessary. Refer to the mainframe manual for a complete description of the readout system.

Basic Readout Operation. In a non-programmable mainframe, the plug-in receives time-slot pulses on the time-slot lines (TS1-TS10). These lines are asserted (Pulled to -15 volts) sequentially so that only one line is asserted at any time. During these pulses data is sent to the mainframe in the form of analog currents on the row current and column current lines. These currents range from zero to 1 milliamp in 100 microamp steps. The current level on these lines defines a particular character in a character selection matrix shown in the mainframe manual.

The data enclosed on the row and column lines is assigned a particular meaning during each time slot (see Tabel 5-2). For example, data on the lines during time slot 2 indicates normal or inverted signal polarity.

7A16P INSTRUCTION

Summing the Time Slots. Programmable plug-ins and mainframes use time-slot lines TS2-TS9 as a data bus, as previously discussed. The time-slot pulses are transmitted to the plug-in as a stream of pulses on TS10. The summation of the time slot pulses appears at pin 10 of U1500. Q1515, CR1515 and R1515 shift the level of the -15 volt pulses to TTL-compatible levels. C1515 is a bypass capacitor to keep the voltage at this point from changing rapidly as U1520E changes state. This improves noise immunity and prevents false pulses from clocking U1230. U1520E inverts the pulses and improves their risetime. The output of U1520E drives a four-bit counter (U1230). We'll come back to this counter shortly.

TS1 is asserted during its normal time-slot in both programmable and non-programmable mainframes. VR1236, R1236, R1234 and Q1230 shift the level of the TS-1 pulse and invert it. VR1230 and R1230 shift the output of Q1230 to TTL levels. This output pulse clears U1230 to insure that the counter always starts at zero during time-slot 1.

At the end of time-slot 1, pin 3 of U1230 goes low, enabling the counter. The output of U1520E also goes low, and the falling edge clocks U1230. U1230 continues to count up in binary until time slot 1 is asserted again at the beginning of the next train of time slot pulses. When time slot 1 is asserted, the counter is cleared and process repeats itself. As a result, the $Q_A - Q_D$ outputs of U1230 count from zero to nine and start over. These outputs drive U1220 and U1310.

Table 5-2
Standard Readout Format

Time Slot Number	Description
TS-1	Determines the decimal magnitude (number of zeroes displayed or prefix change information) or the IDENTIFY function. (No display during this time-slot.)
TS-2	Indicates normal or inverted input (no display for normal input).
TS-3	Indicates calibrated or uncalibrated condition of plug-in variable control. (No display for calibrated condition.)
TS-4	1-2-5 scaling
TS-5 TS-6 TS-7	Not encoded by plug-in. Left blank to allow addition of zeroes by Readout System.
TS-8	Defines the prefix which modifies the units of measurement.
TS-9 TS-10	Defines the units of measurement of the plug-in unit. May be standard units of measurement (V,A,S, etc) or special units selected from the character selection matrix.

Selecting Row and Column Currents. U1220 is a four-to-ten line decoder that asserts one output for each binary input word from zero through nine (outputs 0 and 9 are not used). Output pins 2,3,4,9 and 10 drive current switches that sink the necessary row and column currents during time-slots 2,3,4,8 and 9. For example, during time-slots 2,3 and 9, Q1414 is on. Since the row and column current lines are virtual grounds, when Q100 is on, it sinks 100 microamps on the row current line.

7A16P INSTRUCTION

U1310 takes the BCD coded time-slot number from U1230 and the information on W1-W12 from the MPU. On the basis of these inputs U1310 sinks a selected amount of current on pin 19. This current and the current in Q1410, Q1400, Q1414, Q1300 and Q1302 combine to form the row and column current for each time slot, and as a result, determine the character that is displayed.

Encoding a Time-Slot. Now let's go through an example of how one time-slot's data is encoded to illustrate the operation of the system. During time-slot 1 U1230 is cleared, so the outputs of U1230 are all low. The outputs of U1220 are all high, so Q1410, Q1400 and Q1414 are off. The outputs of U1420A and U1330A are also low, so the A,B,C and D inputs of U1310 are low.

Assume for this example that the IDENTify button on the probe is pressed (IDEN is asserted). With these input conditions, U1310 sinks 1 ma. of current at pin 19. When TS-1 goes low, 200 microamps of current also flows through R1308 and R1309. The resulting current on the column output is 1.2 milliamps and the row current is 200 microamps. Referring to the character selection matrix shown in the mainframe manual, this combination causes the word IDENTIFY to be displayed.

the TS-1 pulse also goes to Q1300 and Q1302. If a X10 or X100 encoding probe is connected, the corresponding transistors (both Q1300 and Q1302 for X100) are on and they source current into the row-current output during time-slot 1. When the next time-slot pulse arrives, U1230 is incremented and the normal or inverted signal information (TS-2) is encoded and sent to the mainframe.

MPU Control Example

We've discussed the components of the microprocessor system and the analog circuitry. Now let's see how the MPU controls the plug-in by going through one routine in the ROM program.

Recall from our discussion of the Positioning Circuit that the DC positioning current came from a 10-bit Digital to Analog Converter (U810). The input word for the DAC is set by the microprocessor. When the plug-in is in remote mode, the POS command sets the value of this word.

7A16P INSTRUCTION

If the 7A16P is in local mode, the POSITION control drives a tracking analog-to-digital converter consisting of a comparator circuit, the microprocessor and the DAC. If, for example, the POSITION control (R020 at the left edge of schematic 4) is turned clockwise (up), the voltage at FB5 becomes more negative. The current through R210 increases and the voltage at pin 11 of U120D and pin 4 of U220A becomes negative. As a result, the output of U220A switches high. We'll come back to this point shortly.

$\overline{\text{FPEN}}$ (Front Panel Enable) at the right-center of schematic 4 is asserted when the 7A16P is in local mode. The low on $\overline{\text{FPEN}}$ enables U1330B so the phase-2 clock pulses appear at its output and are inverted by U500D. These clock pulses go to U610B and U610C at the top-center of schematic 4. When the output of U220A switches high as just discussed, the clock pulses appear at the output of U610C (POSUP). POSUP goes to one of the interrupt inputs of U1000 at the bottom-center of schematic 3. The negative transition on this input sets the interrupt request flag in the control register of the PIA. At the same time $\overline{\text{IRQA}}$ goes low, asserting the $\overline{\text{IRQ}}$ input of the MPU. The MPU saves its current status and sets the interrupt mask bit so that no further interrupts can occur until this one is serviced or the mask is cleared under program control. Then the processor jumps to a routine that reads the PIA control registers looking for a set interrupt flag. When the MPU reads control register A of U1000, it finds the POSUP interrupt flag (bit 6 of the register) set. It then clears the flag and jumps to a service routine that takes control of the DAC input word.

The service routine checks if the interrupt was from the POSUP or POSDN comparators. For our example, the POSUP flag was set, so the service routine increments the value of the DAC input word. As a result, the output voltage at pin 3 goes more negative. The output of U710 swings positive and begins to compensate for the change in the voltage level at the input of the comparators. If the voltage at the inputs of the comparators is balanced to between +0.09 volts and +0.12 volts, the outputs of both comparators go low and the POSUP and POSDN outputs both go high.

7A16P INSTRUCTION

Since the POSITION control moves very slowly in relation to the MPU's speed, the POSITION service routine increments or decrements the value of the DAC input word by one and then checks all interrupts again. This allows other faster interrupts, such as transfers on the IEEE 488 bus, to be services while the operator adjusts the POSITION control. If the output of the DAC rises enough when the input word is incremented to bring the comparator inputs within their stable "window", no further interrupts occur. If the comparators' input voltage is not within this window, the POSUP interrupt occurs again on the next falling edge of POTCK. The MPU re-enters the interrupt routine and increments the DAC input word again. This process is repeated until the POSUP interrupt stops occurring or the 10-bit word reaches its maximum or minimum value. The positioning current that is added to the signal, as previously discussed, comes from the output of U710C (upper-left of schematic 4).

If no interrupts occur and the MPU becomes idle, it asserts the $\overline{\text{STOP}}$ line. This stops the clock to minimize noise in the analog circuits. When an interrupt occurs, or an IFC message is received, the clock restarts and the MPU executes a power-up routine.

The MPU controls the attenuator, front-panel buttons, front-panel LED's and the GPIB interface in a similar interrupt driven fashion.

SECTION 6

CALIBRATION

Introduction

To assure instrument accuracy, check the calibration of the 7A16P every 1000 hours of operation or every six months if used infrequently. Before complete calibration, thoroughly clean and inspect this instrument as outlined in the Maintenance section.

Tektronix Field Service. Tektronix, Inc., provides complete instrument repair and recalibration service at local Field Service Centers and the Factory Service Center. Contact your local Field Office or representative for further information.

Performance Check. The performance of this instrument can be checked by performing only the steps listed in the Performance Check procedure. These steps check the instrument against the tolerances listed as Performance Requirements (see Specification section of this manual).

Limits and tolerances given in other check steps are calibration guides and should not be interpreted as instrument specifications. Operator front-panel adjustments are adjusted as part of the Performance Check procedure.

Calibration. To verify proper calibration of the 7A16P and to prevent unnecessary re-calibration of the entire instrument, perform the **Adjust-** portion of a step only if the tolerance given in the **Check-** part of the step is not met.

When performing a complete calibration procedure, make each adjustment to the exact setting even if the **Check-** is within allowable tolerance.

Test Equipment Required

General. The following test equipment and accessories, or their equivalent, is required for complete calibration of the 7A16P. Specifications given for the test equipment are the minimum necessary for accurate calibration. Therefore, the specifications of any test equipment used must meet or exceed the listed specifications. All test equipment is assumed to be correctly calibrated and operating within the listed specifications. Detailed operating instructions for the test equipment are not given in this procedure. Refer to the instruction manual for the test equipment if more information is needed. Table 6-1 shows a complete list of the test equipment.

Calibration Equipment Alternatives. All of the listed test equipment is required to completely check and adjust this instrument. The calibration procedure is based on the first item of equipment given as an example of applicable equipment. When other equipment is substituted, control settings or the calibration set-up may need to be altered slightly to meet the requirements of the substitute equipment. If the exact item of test equipment given as an example in the Test Equipment list is not available, first check the Specifications column carefully to see if any other equipment is available which might suffice. Then check the Usage column to see what this item of test equipment is used for. If used for a check or adjustment which is of little or no importance to your measurement requirements, the item and corresponding step(s) can be deleted.

Checking Programmable Features. The basic 7A16P calibration procedure does not require a controller. If an IEEE 488 interfaced controller is available, the programmable features of the 7A16P can be tested by sending commands to the plug-in over the IEEE 488 bus. Refer to the programming section of this manual for specific information on the commands.

The commands can also be used to change the 7A16P settings during the calibration procedure. For example, a program loop could be written to repetitively switch the 7A16P POLARITY, simplifying the balance adjustments.

TABLE 6-1
Test Equipment

Description	Minimum Specifications	Usage	Example of Applicable Test Equipment
Calibration Mainframe	7000-Series programmable mainframe, 7912AD required to check 7A16P maximum bandwidth and rise time.	Used throughout procedure to provide display.	Tektronix 7912AD Programmable Digitizer and necessary peripherals.
Time Base Unit	7B-Series time base unit. Sweep speed to 2ns/DIV.	Used throughout procedure to provide horizontal sweep.	Tektronix 7B90P Programmable Time Base.
Calibration Generator	Standard Amplitude output: Amplitude accuracy-within 0.25%; signal amplitude-20 mV to 5V; Frequency-1 KHz square wave; Fast Rise output: Amplitude-at least 1V into 50 ohms. Risetime-less than 1ns.	Used for gain calibration, low- and high-frequency compensation.	Tektronix PG506 Calibration Generator. ¹
50-ohm Feed-through Termination	Connectors-BNC	Used throughout procedure.	Tektronix part number 011-0049-01.

TABLE 6-1 (continued)

Description	Minimum Specifications	Usage	Example of Applicable Test Equipment
Constant Amplitude Signal Generator	Upper frequency range-200 MHz; reference frequency-50 KHz; constant amplitude accuracy-within 5% at maximum output; Amplitude range -5mV to 5.5V peak-to-peak into 50 ohms	Used for Bandwidth check.	Tektronix SG503 leveled sine Wave generator. ¹
BNC cable	Connectors-BNC; length 42 inches	Used through-out procedure.	Tektronix part number 012-0482-00
RC Normalizer	Time Constant-one-Megohm x20 picofarads; Connectors-BNC; attenuation-2x.	Used for compensation adjustment.	Tektronix part number 067-0583-00
Plug-in Extender		Used for MPU Clock adjust procedure.	Tektronix Calibration fixture - part number 067-0589-00.
X10 Attenuator	Connectors-BNC		Tektronix part number 011-0059-01

¹ Requires TM 500-Series Power Module.

Performance Check Procedure

1. Insert the 7A16P into the mainframe. Turn on the mainframe power and allow 20 minutes warm-up time before proceeding.
2. Set the 7912AD to LOCAL and TV mode.
3. Adjust the Graticule Intensity and Focus for a sharp graticule.

CAUTION

The writing beam intensity in the 7912AD is critical. Excessive intensity can permanently damage the scan converter target. Many portions of the Performance Check and Calibration procedures require adjustment of intensity or sweep speed. Remember that reducing sweep speed has the same effect as increasing intensity. Always reduce intensity before reducing sweep speed.

Checking Front-Panel Functions and Readout

1. **Check-** that all front panel buttons and controls operate as discussed in the Manual Operation section of this manual.
2. **Check-** that the readout is correct for all TIME/DIV ranges.

Test Set-Up

Set the 7A16P controls as follows:

VOLTS/DIV:	10 mV.
VARIABLE:	CAL (pressed in)
POSITION:	Midrange
INPUT:	DC

7A16P INSTRUCTION

Checking Balance

1. **Check-** Input R Balance by setting the INPUT to GND and the VOLTS/DIV to 10 mV. The vertical deflection should be 0.5 major division or less while switching between 1-Megohm and 50-ohm input impedance.
2. **Check-** 2.5 Balance for a vertical deflection of 0.5 division or less while switching between 20 mV/DIV and 50 mV/DIV.
3. **Check-** Invert Balance for a vertical trace deflection of 0.5 division or less while switching between +UP and INVerted.
4. **Check-** 2X Balance for a vertical trace shift of 0.5 division or less while switching between 10 mV/DIV and 20 mV/DIV.
5. **Check-** Variable Balance for a vertical deflection of 0.5 divisions or less while rotating the VARIABLE control through its range.

Checking Gain.

1. Connect a BNC cable from the constant-amplitude output of the Calibration Generator to the A input of the 7A16P. Set the generator amplitude for 50 mV and check for a display of five vertical divisions when the 7A16P is set at 10 mV/DIV.
2. Set the generator output amplitude to 100 mV and check for a display of five divisions with the 7A16P set to 20 mV/DIV.
3. **Check-** that the vertical deflection is within 2% of the generator's output amplitude in all VOLTS/DIV ranges.

Checking Rise Time

1. Connect the positive-transition fast-rise output of the Calibration Generator to the A input of the 7A16P. Set the 7A16P input impedance to 50 ohms and the VOLTS/DIV to 10 millivolts.
2. Set the generator and 7A16P to provide a five division display.

7A16P INSTRUCTION

3. **Check-** the rise time on the positive-going transition. The rise time displayed will include the 7A16P, mainframe and generator rise time. Using a generator with a one nanosecond rise time and a 7900-Series mainframe, the measured rise time should be two nanoseconds or less. The system rise time can be computed from the following formula:

$$t_{rs} = (t_{rm}^2 - t_{rg}^2)^{1/2}$$

where t_{rs} = system rise time - given in specifications.
 t_{rm} = measured rise time.
 t_{rg} = generator rise time.

4. Set the 7A16P VOLTS/DIV to 100 millivolts and repeat steps two and three.

Checking Bandwidth

1. Connect the leveled output of the constant-amplitude sine-wave generator to the 7A16P.

2. Set the 7A16P INPUT impedance to 50-ohms.

3. Set the generator to its reference frequency (50 kilohertz for the SG503) and adjust the output amplitude to obtain a six division display.

4. Increase the generator frequency to the system bandwidth shown in the specifications section.

5. **Check-** that the displayed amplitude is 4.2 divisions or greater.

6. Set the 7A16P BANDWIDTH switch to 20 MHz (BW LIM under program control) and reset the generator frequency to 20 megahertz. The display amplitude should be 4.2 divisions when the generator is set to 20 megahertz ± 3 megahertz.

Calibration Procedure

The following procedure is arranged so that the 7A16P can be calibrated with the least interaction of adjustments and re-connection of equipment. The control settings and test equipment set-up throughout the procedure continue from the preceding steps unless otherwise noted. Refer to Fig. 6-1a and b for the location of adjustments. The test set-up is summarized at the beginning of each section of the calibration procedure. When performing the complete procedure, this summary provides a check of the instrument settings. Any part of the calibration procedure can be performed by setting up the equipment as shown in the tables.

NOTE

Control titles that are printed on the 7A16P front panel are capitalized (e.g. POSITION). Internal adjustments and associated equipment controls are initially capitalized only (e.g., Pulse Amplitude).

Preliminary Procedure for Calibration

1. Refer to the mainframe manual and remove the mainframe side covers.
2. Remove the 7A16P side panels.
3. Insert the plug-in extender into the mainframe vertical compartment and plug the 7A16P into the extender.
4. Install the time base into the mainframe horizontal compartment.
5. Turn the mainframe power on and adjust for a visible trace. Allow 20 minutes warm-up time before proceeding.

NOTE

This instrument should be calibrated at an ambient temperature of +20 degrees C to +30 degrees C for best overall accuracy. The performance of the instrument can be checked at any temperature within the 0 degrees C to +40 degrees C range.

Check/Adjust MPU Clock Speed**Test Set-Up**

Set the 7A16P controls as follows:

VOLTS/DIV: 100 mV.
 VARIABLE: CAL (pressed in)
 POSITION: Midrange
 INPUT: A input, DC Coupling, 1-Megohm
 POLARITY: +UP

1. Remove the STOP strap, P1420, on the Programming Logic Board (see Fig. 6-1a).
2. Install a X10 probe on the A input of the 7A16P. Connect the probe to TP626 on the Programming Logic Board.
3. Set the time base for 100 ns/DIV.
4. Press the POLARITY button once to start the clock, then press it again to reset the POLARITY to +UP.
5. **Check-** that the pulse width is between 480 nanoseconds and 520 nanoseconds.
6. **Adjust-** R514 for a 500 nanosecond pulse width.
7. Move the probe to TP726.
8. **Check-** that the pulse width is between 480 nanoseconds and 520 nanoseconds.

7A16P INSTRUCTION

9. **Adjust-** R328 for a 500 nanosecond pulse width.
10. Turn the mainframe power off and remove the 7A16P from the extender. Install the STOP strap, P1420.
11. Remove the X10 probe.

NOTE

Turn the mainframe power off before removing or inserting plug-ins.

12. Remove the plug-in extender and install the 7A16P in its place.
13. Turn the mainframe power on.

Check/Adjust DC Balance

Test Set-Up

Set the 7A16P controls as follows:

VOLTS/DIV: 10 mV.
VARIABLE: CAL (pressed in)
POSITION: Midrange
INPUT: A input, DC Coupling
POLARITY: +UP

1. **Check-** that the vertical trace shift is 0.5 division or less while switching between 1-Megohm and 50-ohm input impedance.
2. **Adjust-** R315, Input R Balance, for minimum trace deflection while switching between 1-Megohm and 50-ohm input impedance.
3. **Check-** that the vertical trace shift is 0.5 division or less while switching between 20 mV/DIV and 50 mV/DIV.

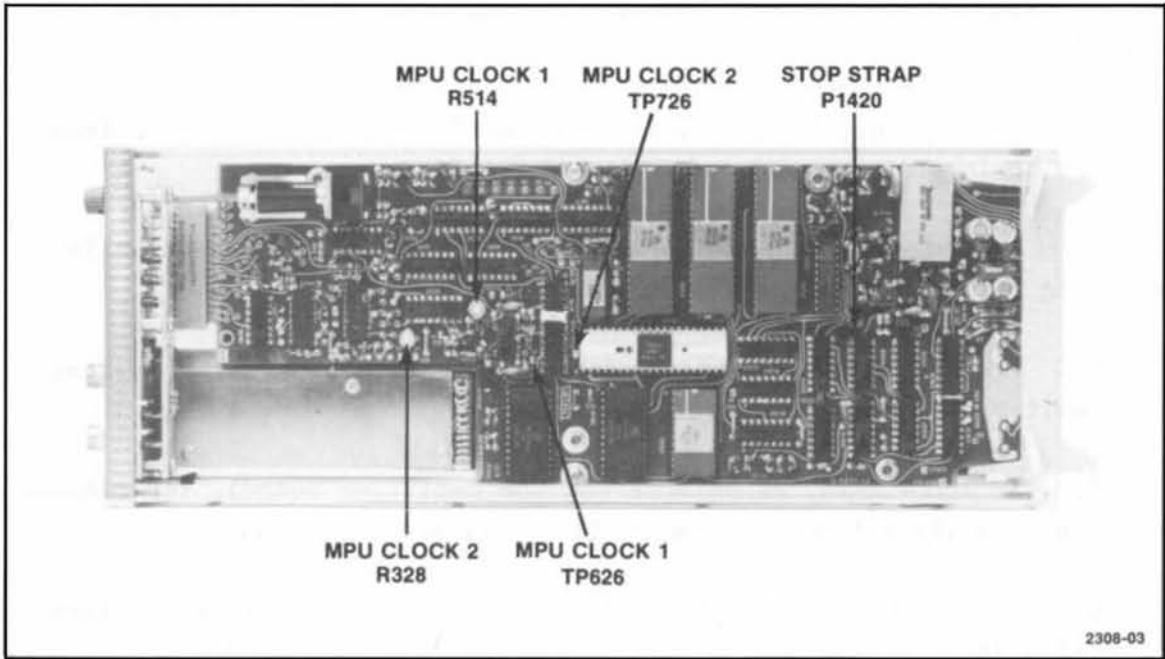

2308-03

Fig. 6-1a. Test Point and Adjustment Locations Programming Logic Board

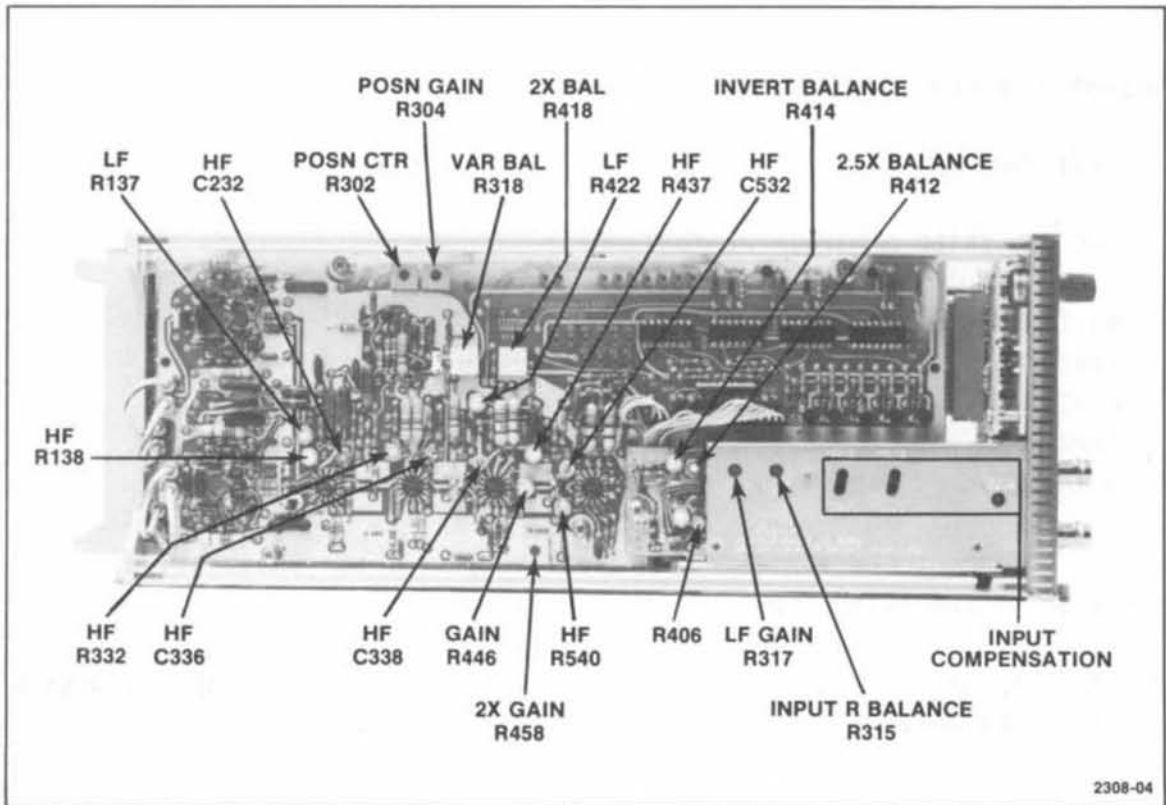

2308-04

Fig. 6-1b. Test Point and Adjustment Locations Attenuator and Amplifier Board

7A16P INSTRUCTION

4. **Adjust-** R412, 2.5X Balance, for minimum trace deflection while switching between 20 mV/DIV and 50 mV/DIV.
5. **Check-** that the vertical trace shift is 0.5 division or less while switching between +UP and INVERTED POLARITY.
6. **Adjust-** R414, Invert Balance, for minimum trace shift while switching between +UP and INVERTED.
7. **Check-** that the vertical trace shift is 0.5 division or less while switching between 10 mV/DIV and 20 mV/DIV.
8. **Adjust-** R418, 2X Balance (on the amplifier board), for minimum trace shift while switching between 10 mV/DIV and 20 mV/DIV.
9. **Check-** that the vertical trace shift is 0.5 division or less while rotating the VARIABLE control throughout its range.
10. **Adjust-** R318, Variable Balance, for minimum trace deflection while rotating the VARIABLE control through its full range.

Adjust Low Frequency Gain

Test Set-Up

Set the 7A16P controls as follows:

VOLTS/DIV:	10 mV.
VARIABLE:	CAL (pressed in)
POSITION:	Midrange
INPUT:	A input, DC Coupling, 50-ohms
POLARITY:	+UP

1. Connect the standard-amplitude output of the Calibration Generator to the 7A16P input.
2. Adjust the time base for a four- to five- cycle display, with a one kilohertz output frequency from the generator.

7A16P INSTRUCTION

3. Set R422 (see Fig. 6-1b) fully counterclockwise.
4. **Adjust-** R317 (on the attenuator board) for a flat top on the square wave.
5. Turn R422 clockwise until the corners just begin to overshoot and back off slightly.
6. Recheck R317 and R422.

Check/Adjust Gain

Test Set-Up

Set the 7A16P controls as follows:

VOLTS/DIV: 10 mV.
VARIABLE: CAL (pressed in)
POSITION: Midrange
INPUT: A input, DC Coupling, one megohm
POLARITY: +UP

1. Center the front panel GAIN control.
2. Set the Calibration Generator for 50 mV output.
3. **Check-** that the display amplitude is five divisions ± 0.1 divisions.
4. **Adjust-** R446, GAIN (on the amplifier board) for a vertical display of five divisions.
5. Set the 7A16P to 20 mV/DIV and the generator to 100 mV output.
6. **Check-** that the display amplitude is five divisions ± 0.1 division.
7. **Adjust-** R458, 2X Gain, to provide a display amplitude of five divisions.

7A16P INSTRUCTION

8. Set the 7A16P to 50 mV/DIV and the generator output to 200 mV.
9. **Check-** that the display amplitude is four divisions ± 0.1 division.
10. **Adjust-** R406, on the attenuator board, for a display amplitude of exactly four divisions.
11. These adjustments interact with each other, so it may be necessary to repeat the steps in this section.
12. **Check-** that the display amplitude is within 2% of the generator output amplitude on all VOLTS/DIV ranges.
13. Set the 7A16P INPUT to INVert.
14. **Check-** that the amplitude of the inverted display is within 2% of the generator output amplitude.
15. Set the 7A16P INPUT to Limited (20 MHz.) BANDWIDTH.

NOTE

The calibration generator output frequency must be below 200 kilohertz. Some waveform distortion may occur above one kilohertz.

16. **Check-** that the amplitude of the display is within 2% of the generator output.

Adjust Positioning**Test Set-Up**

Set the 7A16P controls as follows:

VOLTS/DIV: 20 mV.
VARIABLE: CAL (pressed in)
POSITION: Midrange
INPUT: A input, DC Coupling, 50-ohms
POLARITY: +UP

1. Set the Calibration Generator for a 200 millivolt square wave output.
2. Set the 7A16P to DC coupling and 20 mV/DIV. This produces a display amplitude of ten divisions.
3. Turn the POSITION control fully counterclockwise.
4. **Check-** that the top of the square wave is at least 0.2 division below the center graticule line.
5. **Adjust-** R302, Position Centering, until the top of the square wave is 0.2 division below the center graticule line.
6. Set the 7A16P POLARITY to INVERTed.
7. Turn the POSITION control fully clockwise.
8. **Check-** that the bottom of the square wave is at least 0.2 division above the center graticule line.
9. **Adjust-** R302, Position Centering, until the bottom of the square wave is 0.2 division above the center graticule line.
10. Recheck steps six through ten. If the Position Centering cannot be adjusted to meet the condition described in steps six and ten, adjust R304, Position Gain, to increase (counterclockwise) or decrease (clockwise) gain as necessary. Then repeat steps six through ten.

Adjust Input Compensation

Test Set-Up

Set the 7A16P controls as follows:

VOLTS/DIV: 20 mV.
VARIABLE: CAL (pressed in)
POSITION: Midrange
INPUT: A input, DC Coupling, 1-Megohm
POLARITY: +UP

1. Turn the mainframe power off.
2. Remove the 7A16P and install the plug-in extender in its place.
3. Plug the 7A16P into the extender.
4. Turn the mainframe power on.
5. Connect the high-amplitude output of the Calibration Generator to the 7A16P input through a 50-ohm terminator, an X10 attenuator, and the RC Normalizer (the Normalizer must be connected to the 7A16P INPUT connector).
6. Set the 7A16P input impedance to 1 Megohm and set the VOLTS/DIV to 20 mV.
7. **Adjust-** the generator for a six-division display.
8. **Adjust-** C002 for best square corners and flat tops.
9. Turn the mainframe power off.
10. Remove the plug-in extender and install the 7A16P in its place.
11. Turn the mainframe power on.

Adjust Attenuator Compensation

Test Set-Up

Set the 7A16P controls as follows:

VOLTS/DIV: 100 mV.
VARIABLE: CAL (pressed in)
POSITION: Midrange
INPUT: A input, DC Coupling, 1-Megohm
POLARITY: +UP

1. Remove the X10 attenuator from the cable connecting the 7A16P and the calibration generator.
2. Adjust the Calibration Generator for a six division display.
3. **Adjust-** C110 for a fast rise on the leading edge.
4. **Adjust-** C112 for best flat top on the square wave.
5. Repeat these adjustments for optimum response.
6. Remove the RC Normalizer and terminator.
7. Set the 7A16P for 1 V/DIV and adjust the generator for a six division display.
8. **Adjust-** C210 for a fast leading edge.
9. **Adjust-** C212 for best flat top.

Adjust Low Frequency Compensation

Test Set-Up

Set the 7A16P controls as follows:

VOLTS/DIV: 50 mV.
VARIABLE: CAL (pressed in)
POSITION: Midrange
INPUT: A input, DC Coupling, 50-ohms
POLARITY: +UP

1. Connect the high-amplitude output of the Calibration Generator to the 7A16P through a X10 attenuator.
2. Set the generator to obtain approximately six divisions of one kilohertz square wave.
3. **Adjust-** R137, Low Frequency Compensation for best flat top (minimum tilt).

Adjust High Frequency Compensation

Test Set-Up

Set the 7A16P controls as follows:

VOLTS/DIV: 10 mV.
VARIABLE: CAL (pressed in)
POSITION: Midrange
INPUT: A input, DC Coupling, 50 ohms.
POLARITY: +UP

1. Set the generator for a one kilohertz fast-rise pulse.
2. Set the 7A16P to 10 mV/DIV and adjust the generator for approximately six divisions of vertical deflection.
3. Set the time base to obtain a triggered display at approximately 100 microseconds per division.

7A16P INSTRUCTION

4. **Adjust-** R422 for sharpest front corners and flat tops.
5. Set the time base unit to 20 nanoseconds per division and the calibration generator to one megahertz.
6. **Adjust-** R332 and C336 for best front corner and flat top.
7. Set the time base unit to five nanoseconds per division.
- 10 **Adjust-** high frequency compensation controls - R138, C232, R437, C338, R540 and C532 for best front corner and flat top.

Check Bandwidth

Test Set-Up

Set the 7A16P controls as follows:

VOLTS/DIV: 10 mV.
VARIABLE: CAL (pressed in)
POSITION: Midrange
INPUT: A input, DC Coupling, 50 ohms
POLARITY: +UP

1. Connect the Constant Amplitude Signal Generator to the 7A16P input through a X10 attenuator.
2. Set the generator to the reference frequency of 50 kilohertz and adjust the output amplitude for a six division display.
3. Increase the generator frequency to 200 megahertz.
4. **Check-** that the amplitude of the display is 4.2 divisions or greater.
5. Set the 7A16P BANDWIDTH to 20 MHz.
6. Set the Constant Amplitude Signal Generator frequency to 20 megahertz.

7A16P INSTRUCTION

7. **Check-** that the display amplitude is 4.2 divisions when the generator is set to 20 megahertz ± 3 megahertz.

8. Turn the mainframe power off and disconnect all test equipment.

9. Remove the 7A16P and replace the mainframe and plug-in side covers.

This completes the 7A16P Calibration Procedure.

REPLACEABLE ELECTRICAL PARTS

PARTS ORDERING INFORMATION

Replacement parts are available from or through your local Tektronix, Inc. Field Office or representative.

Changes to Tektronix instruments are sometimes made to accommodate improved components as they become available, and to give you the benefit of the latest circuit improvements developed in our engineering department. It is therefore important, when ordering parts, to include the following information in your order: Part number, instrument type or number, serial number, and modification number if applicable.

If a part you have ordered has been replaced with a new or improved part, your local Tektronix, Inc. Field Office or representative will contact you concerning any change in part number.

Change information, if any, is located at the rear of this manual.

SPECIAL NOTES AND SYMBOLS

X000 Part first added at this serial number
00X Part removed after this serial number

ITEM NAME

In the Parts List, an Item Name is separated from the description by a colon (:). Because of space limitations, an Item Name may sometimes appear as incomplete. For further Item Name identification, the U.S. Federal Cataloging Handbook H6-1 can be utilized where possible.

ABBREVIATIONS

ACTR	ACTUATOR	PLSTC	PLASTIC
ASSY	ASSEMBLY	QTZ	QUARTZ
CAP	CAPACITOR	RECP	RECEPTACLE
CER	CERAMIC	RES	RESISTOR
CKT	CIRCUIT	RF	RADIO FREQUENCY
COMP	COMPOSITION	SEL	SELECTED
CONN	CONNECTOR	SEMICOND	SEMICONDUCTOR
ELCTLT	ELECTROLYTIC	SENS	SENSITIVE
ELEC	ELECTRICAL	VAR	VARIABLE
INCAND	INCANDESCENT	WW	WIREWOUND
LED	LIGHT EMITTING DIODE	XFMR	TRANSFORMER
NONWIR	NON WIREWOUND	XTAL	CRYSTAL

Replaceable Electrical Parts—7A16P

CROSS INDEX—MFR. CODE NUMBER TO MANUFACTURER

Mfr. Code	Manufacturer	Address	City, State, Zip
00853	SANGAMO ELECTRIC CO., S. CAROLINA DIV.	P O BOX 128	PICKENS, SC 29671
01121	ALLEN-BRADLEY COMPANY	1201 2ND STREET SOUTH	MILWAUKEE, WI 53204
01295	TEXAS INSTRUMENTS, INC., SEMICONDUCTOR GROUP	P O BOX 5012, 13500 N CENTRAL EXPRESSWAY	DALLAS, TX 75222
04222	AVX CERAMICS, DIVISION OF AVX CORP.	P O BOX 867, 19TH AVE. SOUTH	MYRTLE BEACH, SC 29577
04713	MOTOROLA, INC., SEMICONDUCTOR PROD. DIV.	5005 E MCDOWELL RD, PO BOX 20923	PHOENIX, AZ 85036
07263	FAIRCHILD SEMICONDUCTOR, A DIV. OF FAIRCHILD CAMERA AND INSTRUMENT CORP.	464 ELLIS STREET	MOUNTAIN VIEW, CA 94042
07716	TRW ELECTRONIC COMPONENTS, IRC FIXED RESISTORS, BURLINGTON DIV.	2850 MT. PLEASANT	BURLINGTON, IA 52601
12697	CLAROSTAT MFG. CO., INC.	LOWER WASHINGTON STREET	DOVER, NH 03820
14193	CAL-R, INC.	1601 OLYMPIC BLVD.	SANTA MONICA, CA 90404
14433	ITT SEMICONDUCTORS	3301 ELECTRONICS WAY P O BOX 3049	WEST PALM BEACH, FL 33402
14552	MICRO SEMICONDUCTOR CORP.	2830 E FAIRVIEW ST.	SANTA ANA, CA 92704
17856	SILICONIX, INC.	2201 LAURELWOOD DRIVE	SANTA CLARA, CA 95054
18324	SIGNETICS CORP.	811 E. ARQUES	SUNNYVALE, CA 94086
22526	BERG ELECTRONICS, INC.	YOUK EXPRESSWAY	NEW CUMBERLAND, PA 17070
24546	CORNING GLASS WORKS, ELECTRONIC COMPONENTS DIVISION	550 HIGH STREET	BRADFORD, PA 16701
27014	NATIONAL SEMICONDUCTOR CORP.	2900 SEMICONDUCTOR DR.	SANTA CLARA, CA 95051
32997	BOURNS, INC., TRIMPOT PRODUCTS DIV.	1200 COLUMBIA AVE.	RIVERSIDE, CA 92507
50157	MIDWEST COMPONENTS INC.	P. O. BOX 787 1981 PORT CITY BLVD.	MUSKEGON, MI 49443
50434	HEWLETT-PACKARD COMPANY	640 PAGE MILL ROAD	PALO ALTO, CA 94304
51642	CENTRE ENGINEERING INC.	2820 E COLLEGE AVENUE	STATE COLLEGE, PA 16801
55680	NICHICON/AMERICA/CORP.	6435 N PROESEL AVENUE	CHICAGO, IL 60645
56289	SPRAGUE ELECTRIC CO.	87 MARSHALL ST.	NORTH ADAMS, MA 01247
57668	R-OHM CORP.	16931 MILLIKEN AVE.	IRVINE, CA 92713
59660	TUSONIX INC.	2155 N FORBES BLVD	TUCSON, AZ 85705
72982	ERIE TECHNOLOGICAL PRODUCTS, INC.	644 W. 12TH ST.	ERIE, PA 16512
73138	BECKMAN INSTRUMENTS, INC., HELIPOT DIV.	2500 HARBOR BLVD.	FULLERTON, CA 92634
73899	JFD ELECTRONICS COMPONENTS CORP.	PINETREE ROAD	OXFORD, NC 27565
74970	JOHNSON, E. F., CO.	299 10TH AVE. S. W.	WASECA, MN 56093
75042	TRW ELECTRONIC COMPONENTS, IRC FIXED RESISTORS, PHILADELPHIA DIVISION	401 N. BROAD ST.	PHILADELPHIA, PA 19108
78488	STACKPOLE CARBON CO.		ST. MARYS, PA 15857
80009	TEKTRONIX, INC.	P O BOX 500	BEAVERTON, OR 97077
90201	MALLORY CAPACITOR CO., DIV. OF P. R. MALLORY AND CO., INC.	3029 E. WASHINGTON STREET P. O. BOX 372	INDIANAPOLIS, IN 46206
91418	RADIO MATERIALS COMPANY, DIV. OF P.R. MALLORY AND COMPANY, INC.	4242 W BRYN MAWR	CHICAGO, IL 60646
91637	DALE ELECTRONICS, INC.	P. O. BOX 609	COLUMBUS, NE 68601
95348	GORDOS CORPORATION	250 GLENWOOD AVENUE	BLOOMFIELD, NJ 07003

Ckt No.	Tektronix Part No.	Serial/Model No.		Name & Description	Mfr Code	Mfr Part Number
		Eff	Dscont			
A10	670-5047-00	B010100	B041414	CKT BOARD ASSY:ATTENUATOR	80009	670-5047-00
A10	670-5047-01	B041415		CKT BOARD ASSY:ATTENUATOR	80009	670-5047-01
A20	670-5046-00			CKT BOARD ASSY:ACTUATOR	80009	670-5046-00
A30	670-4916-00	B010100	B010171	CKT BOARD ASSY:PROGRAMMING LOGIC	80009	670-4916-00
A30	670-4916-01	B010172	B029999	CKT BOARD ASSY:PROGRAMMING LOGIC	80009	670-4916-01
A30	670-4916-02	B030000	B030664	CKT BOARD ASSY:PROGRAMMING LOGIC	80009	670-4916-02
A30	670-4916-03	B030665	B041353	CKT BOARD ASSY:PROGRAMMING LOGIC	80009	670-4916-03
A30	670-4916-04	B041354	B041606	CKT BOARD ASSY:PROGRAMMING LOGIC	80009	670-4916-04
A30	670-4916-05	B041607		CKT BOARD ASSY:PROGRAMMING LOGIC	80009	670-4916-05
A31	670-7549-00	B041354	B041606	CKT BOARD ASSY:MEMORY ADAPTER	80009	670-7549-00
A40	670-4913-00			CKT BOARD ASSY:LED	80009	670-4913-00
A50	670-4914-00			CKT BOARD ASSY:SWITCH	80009	670-4914-00
A60	670-4915-00	B010100	B010166	CKT BOARD ASSY:AMPLIFIER	80009	670-4915-00
A60	670-4915-01	B010167	B041593	CKT BOARD ASSY:AMPLIFIER	80009	670-4915-01
A60	670-4915-02	B041594		CKT BOARD ASSY:AMPLIFIER	80009	670-4915-02
A70	388-5478-02			PRINTED WIRING:SHIELD	80009	388-5478-02
AT10112	307-1013-01			ATTENUATOR,FXD:10X	80009	307-1013-01
AT10212	307-1013-03			ATTENUATOR,FXD:10X	80009	307-1013-03
C10000	281-0788-00			CAP.,FXD,CER DI:470PF,10%,100V	72982	8005H9AADW5R471K
C10002	281-0138-00			CAP.,VAR,PLSTC:0.4-1.2PF,600V	74970	273-0001-007
C10006	281-0773-00			CAP.,FXD,CER DI:0.01UF,10%,100V	04222	SA201C103KAA
C10007	281-0672-00			CAP.,FXD,CER DI:11.4PF,1%,500V	59660	374 017C0G01149F
C10008	283-0414-00			CAP.,FXD,CER DI:0.022UF,20%,500V	51642	300-500X7R223M
C10010	281-0788-00			CAP.,FXD,CER DI:470PF,10%,100V	72982	8005H9AADW5R471K
C10100	281-0788-00			CAP.,FXD,CER DI:470PF,10%,100V	72982	8005H9AADW5R471K
C10110	307-1013-01			ATTENUATOR,FXD:10X	80009	307-1013-01
C10112	307-1013-01			ATTENUATOR,FXD:10X	80009	307-1013-01
C10114	283-0299-00			CAP.,FXD,CER DI:51PF,5%,500V	72982	8121N501C0G510J
C10200	281-0759-00			CAP.,FXD,CER DI:22PF,10%,100V	72982	8035D9AADC1G220K
C10202	283-0176-00	B010100	B030664	CAP.,FXD,CER DI:0.0022UF,20%,50V	72982	8121B058X7R0222M
C10202	283-0204-00	B030665		CAP.,FXD,CER DI:0.01UF,20%,50V	72982	8121N061Z5U0103M
C10207	283-0201-00			CAP.,FXD,CER DI:27PF,10%,200V	51642	W150-200 X7R270K
C10210	307-1013-03			ATTENUATOR,FXD:10X	80009	307-1013-03
C10211	283-0154-00			CAP.,FXD,CER DI:22PF,5%,50V	72982	8111B061C0G220J
C10212	307-1013-03			ATTENUATOR,FXD:10X	80009	307-1013-03
C10214	281-0811-00	B010100	B030664	CAP.,FXD,CER DI:10PF,10%,100V	72982	8035D2AADC1G100K
C10214	283-0154-00	B030665		CAP.,FXD,CER DI:22PF,5%,50V	72982	8111B061C0G220J
C10216	283-0175-00			CAP.,FXD,CER DI:10PF,5%,200V	59660	W150-200-NP0100D
C10300	283-0204-00			CAP.,FXD,CER DI:0.01UF,20%,50V	72982	8121N061Z5U0103M
C10303	283-0204-00			CAP.,FXD,CER DI:0.01UF,20%,50V	72982	8121N061Z5U0103M
C10308	283-0158-00			CAP.,FXD,CER DI:1PF,10%,50V	51642	100-050-NP0-109B
C10310	283-0204-00			CAP.,FXD,CER DI:0.01UF,20%,50V	72982	8121N061Z5U0103M
C10400	281-0788-00			CAP.,FXD,CER DI:470PF,10%,100V	72982	8005H9AADW5R471K
C10416	281-0788-00			CAP.,FXD,CER DI:470PF,10%,100V	72982	8005H9AADW5R471K
C20000	283-0000-00			CAP.,FXD,CER DI:0.001UF,+100-0%,500V	59660	0831610Y5P0102D
C20002	281-0775-00			CAP.,FXD,CER DI:0.1UF,20%,50V	04222	SA205E104MAA
C20006	283-0204-00			CAP.,FXD,CER DI:0.01UF,20%,50V	72982	8121N061Z5U0103M
C20010	283-0000-00			CAP.,FXD,CER DI:0.001UF,+100-0%,500V	59660	0831610Y5P0102D
C20014	281-0775-00			CAP.,FXD,CER DI:0.1UF,20%,50V	04222	SA205E104MAA
C20016	281-0775-00			CAP.,FXD,CER DI:0.1UF,20%,50V	04222	SA205E104MAA
C20100	283-0204-00			CAP.,FXD,CER DI:0.01UF,20%,50V	72982	8121N061Z5U0103M
C20102	283-0204-00			CAP.,FXD,CER DI:0.01UF,20%,50V	72982	8121N061Z5U0103M

Replaceable Electrical Parts—7A16P

Ckt No.	Tektronix Part No.	Serial/Model No. Eff	Dscont	Name & Description	Mfr Code	Mfr Part Number
C20106	281-0523-00			CAP.,FXD,CER DI:100PF,+/-20PF,500V	72982	301-000U2M0101M
C20116	281-0523-00			CAP.,FXD,CER DI:100PF,+/-20PF,500V	72982	301-000U2M0101M
C20206	283-0000-00			CAP.,FXD,CER DI:0.001UF,+100-0%,500V	59660	0831610Y5P0102D
C20208	283-0000-00			CAP.,FXD,CER DI:0.001UF,+100-0%,500V	59660	0831610Y5P0102D
C20300	290-0536-00			CAP.,FXD,ELCTLT:10UF,20%,25V	90201	TDC106M025FL
C20310	290-0536-00			CAP.,FXD,ELCTLT:10UF,20%,25V	90201	TDC106M025FL
C30116	283-0111-00			CAP.,FXD,CER DI:0.1UF,20%,50V	72982	8121-N088Z5U104M
C30211	283-0330-00	B010172		CAP.,FXD,CER DI:100PF,5%,50V	51642	150-050-NP0-101J
C30224	283-0010-00			CAP.,FXD,CER DI:0.05UF,+100-20%,50V	56289	273C20
C30316	283-0330-00			CAP.,FXD,CER DI:100PF,5%,50V	51642	150-050-NP0-101J
C30420	283-0010-00			CAP.,FXD,CER DI:0.05UF,+100-20%,50V	56289	273C20
C30422	283-0330-00			CAP.,FXD,CER DI:100PF,5%,50V	51642	150-050-NP0-101J
C30500	283-0010-00			CAP.,FXD,CER DI:0.05UF,+100-20%,50V	56289	273C20
C30520	283-0187-00			CAP.,FXD,CER DI:0.047UF,10%,400V	72982	8131N401X5R0473K
C30610	283-0010-00			CAP.,FXD,CER DI:0.05UF,+100-20%,50V	56289	273C20
C30614	283-0000-00			CAP.,FXD,CER DI:0.001UF,+100-0%,500V	59660	0831610Y5P0102D
C30626	283-0000-00			CAP.,FXD,CER DI:0.001UF,+100-0%,500V	59660	0831610Y5P0102D
C30720	281-0546-00			CAP.,FXD,CER DI:330PF,10%,500V	04222	7001-1380
C30730	283-0111-00	B010100	B041606	CAP.,FXD,CER DI:0.1UF,20%,50V	72982	8121-N088Z5U104M
C30800	283-0060-00			CAP.,FXD,CER DI:100PF,5%,200V	72982	855-535U2J101J
C30810	283-0010-00			CAP.,FXD,CER DI:0.05UF,+100-20%,50V	56289	273C20
C60006	283-0010-00			CAP.,FXD,CER DI:0.05UF,+100-20%,50V	56289	273C20
C60010	283-0600-00			CAP.,FXD,MICA D:43PF,5%,500V	00853	D105E430J0
C60012	283-0644-00			CAP.,FXD,MICA D:150PF,1%,500V	00853	D155F151F0
C60014	283-0010-00			CAP.,FXD,CER DI:0.05UF,+100-20%,50V	56289	273C20
C60040	283-0600-00			CAP.,FXD,MICA D:43PF,5%,500V	00853	D105E430J0
C60042	283-0640-00			CAP.,FXD,MICA D:160PF,1%,100V	00853	D151E161F0
C60044	283-0010-00			CAP.,FXD,CER DI:0.05UF,+100-20%,50V	56289	273C20
C60046	283-0010-00			CAP.,FXD,CER DI:0.05UF,+100-20%,50V	56289	273C20
C60120	283-0002-00			CAP.,FXD,CER DI:0.01UF,+80-20%,500V	91418	SM103Z5014R9
C60122	283-0002-00			CAP.,FXD,CER DI:0.01UF,+80-20%,500V	91418	SM103Z5014R9
C60128	283-0197-00			CAP.,FXD,CER DI:470PF,5%,100V	72982	8121N075C0G0471J
C60143	281-0625-00			CAP.,FXD,CER DI:35PF,5%,500V	59660	308-000C0G0350J
C60212	283-0111-00			CAP.,FXD,CER DI:0.1UF,20%,50V	72982	8121-N088Z5U104M
C60220	283-0002-00			CAP.,FXD,CER DI:0.01UF,+80-20%,500V	91418	SM103Z5014R9
C60224	283-0002-00			CAP.,FXD,CER DI:0.01UF,+80-20%,500V	91418	SM103Z5014R9
C60226	283-0111-00			CAP.,FXD,CER DI:0.1UF,20%,50V	72982	8121-N088Z5U104M
C60232	281-0161-00			CAP.,VAR,CER DI:5-15PF,350V	59660	518-000A5-15
C60314	281-0534-00			CAP.,FXD,CER DI:3.3PF,+/-0.25PF,500V	04222	7001-1316
C60334	283-0201-00			CAP.,FXD,CER DI:27PF,10%,200V	51642	W150-200 X7R270K
C60336	281-0158-00			CAP.,VAR,CER DI:7-45PF,50V	73899	DVJ-5006
C60338	281-0123-00			CAP.,VAR,CER DI:5-25PF,100V	59660	518-000A5-25
C60350	283-0111-00			CAP.,FXD,CER DI:0.1UF,20%,50V	72982	8121-N088Z5U104M
C60424	283-0010-00			CAP.,FXD,CER DI:0.05UF,+100-20%,50V	56289	273C20
C60430	283-0175-00			CAP.,FXD,CER DI:10PF,5%,200V	59660	W150-200-NP0100D
C60434	283-0047-00			CAP.,FXD,CER DI:270PF,5%,500V	72982	0831522Z5D00271J
C60452	283-0111-00			CAP.,FXD,CER DI:0.1UF,20%,50V	72982	8121-N088Z5U104M
C60520	283-0111-00			CAP.,FXD,CER DI:0.1UF,20%,50V	72982	8121-N088Z5U104M
C60522	283-0083-00			CAP.,FXD,CER DI:0.0047UF,20%,500V	72982	811-565C471J
C60526	283-0111-00			CAP.,FXD,CER DI:0.1UF,20%,50V	72982	8121-N088Z5U104M
C60532	281-0151-00			CAP.,VAR,CER DI:1-3PF,100V	59660	518 000 A 1.0 3
C60536	283-0026-00			CAP.,FXD,CER DI:0.2UF,+80-20%,25V	56289	274C3
C60538	281-0814-00			CAP.,FXD,CER DI:100PF,10%,100V	04222	GC70-1-A101K
C60554	283-0000-00			CAP.,FXD,CER DI:0.001UF,+100-0%,500V	59660	0831610Y5P0102D

Ckt No.	Tektronix Part No.	Serial/Model No.		Name & Description	Mfr Code	Mfr Part Number
		Eff	Dscont			
C301130	283-0010-00			CAP.,FXD,CER DI:0.05UF,+100-20%,50V	56289	273C20
C301230	283-0010-00			CAP.,FXD,CER DI:0.05UF,+100-20%,50V	56289	273C20
C301310	283-0000-00			CAP.,FXD,CER DI:0.001UF,+100-0%,500V	59660	0831610Y5P0102D
C301332	283-0119-00			CAP.,FXD,CER DI:2200PF,5%,200V	59660	855-536Y5E0222J
C301400	283-0003-00			CAP.,FXD,CER DI:0.01UF,+80-20%,150V	91418	SP103Z151-4R9
C301432	283-0032-00			CAP.,FXD,CER DI:470PF,5%,500V	72982	0831085Z5E00471J
C301515	283-0060-00			CAP.,FXD,CER DI:100PF,5%,200V	72982	855-535U2J101J
C301518	283-0000-00	B010100	B019999	CAP.,FXD,CER DI:0.001UF,+100-0%,500V	59660	0831610Y5P0102D
C301518	283-0150-00	B020000		CAP.,FXD,CER DI:650PF,5%,200V	59660	0835030Z5E0 651J
C301608	290-0746-00	B010100	B041606	CAP.,FXD,ELCTLT:47UF,+50-10%,16V	55680	16U-47V-T
C301610	290-0745-00			CAP.,FXD,ELCTLT:22UF,+50-10%,25V	56289	502D225
C301620	283-0010-00			CAP.,FXD,CER DI:0.05UF,+100-20%,50V	56289	273C20
C301628	283-0010-00			CAP.,FXD,CER DI:0.05UF,+100-20%,50V	56289	273C20
C301708	290-0746-00			CAP.,FXD,ELCTLT:47UF,+50-10%,16V	55680	16U-47V-T
C301710	290-0745-00			CAP.,FXD,ELCTLT:22UF,+50-10%,25V	56289	502D225
CR20002	152-0141-02			SEMICONV DEVICE:SILICON,30V,150MA	01295	1N4152R
CR20004	152-0141-02			SEMICONV DEVICE:SILICON,30V,150MA	01295	1N4152R
CR20006	152-0141-02			SEMICONV DEVICE:SILICON,30V,150MA	01295	1N4152R
CR20014	152-0141-02			SEMICONV DEVICE:SILICON,30V,150MA	01295	1N4152R
CR20016	152-0141-02			SEMICONV DEVICE:SILICON,30V,150MA	01295	1N4152R
CR20100	152-0141-02			SEMICONV DEVICE:SILICON,30V,150MA	01295	1N4152R
CR20106	153-0057-00			SEMICONV DVC,SE:SILICON,40 PIV,200MA,SEL	80009	153-0057-00
CR20116	153-0057-00			SEMICONV DVC,SE:SILICON,40 PIV,200MA,SEL	80009	153-0057-00
CR30210	152-0075-00			SEMICONV DEVICE:GE,25V,40MA	14433	G866
CR30212	152-0141-02			SEMICONV DEVICE:SILICON,30V,150MA	01295	1N4152R
CR30300	152-0141-02			SEMICONV DEVICE:SILICON,30V,150MA	01295	1N4152R
CR30302	152-0141-02			SEMICONV DEVICE:SILICON,30V,150MA	01295	1N4152R
CR30304	152-0141-02			SEMICONV DEVICE:SILICON,30V,150MA	01295	1N4152R
CR30324	152-0075-00	B010100	B041606	SEMICONV DEVICE:GE,25V,40MA	14433	G866
CR30400	152-0141-02			SEMICONV DEVICE:SILICON,30V,150MA	01295	1N4152R
CR60004	152-0141-02			SEMICONV DEVICE:SILICON,30V,150MA	01295	1N4152R
CR60014	152-0141-02			SEMICONV DEVICE:SILICON,30V,150MA	01295	1N4152R
CR60032	152-0141-02			SEMICONV DEVICE:SILICON,30V,150MA	01295	1N4152R
CR60046	152-0141-02			SEMICONV DEVICE:SILICON,30V,150MA	01295	1N4152R
CR60314	152-0141-02			SEMICONV DEVICE:SILICON,30V,150MA	01295	1N4152R
CR60338	152-0141-02			SEMICONV DEVICE:SILICON,30V,150MA	01295	1N4152R
CR60802	152-0141-02			SEMICONV DEVICE:SILICON,30V,150MA	01295	1N4152R
CR301310	152-0322-00			SEMICONV DEVICE:SILICON,15V,HOT CARRIER	50434	5082-2672
CR301510	152-0141-02			SEMICONV DEVICE:SILICON,30V,150MA	01295	1N4152R
CR301515	152-0141-02			SEMICONV DEVICE:SILICON,30V,150MA	01295	1N4152R
DS30520	150-1036-00			LAMP,LED:RED,3.0V,40MA	01295	TIL 209A
DS40100	150-1036-00			LAMP,LED:RED,3.0V,40MA	01295	TIL 209A
DS40108	150-1036-00			LAMP,LED:RED,3.0V,40MA	01295	TIL 209A
DS40110	150-1036-00			LAMP,LED:RED,3.0V,40MA	01295	TIL 209A
DS40120	150-1036-00			LAMP,LED:RED,3.0V,40MA	01295	TIL 209A
DS40200	150-1036-00			LAMP,LED:RED,3.0V,40MA	01295	TIL 209A
DS40202	150-1036-00			LAMP,LED:RED,3.0V,40MA	01295	TIL 209A
DS40206	150-1036-00			LAMP,LED:RED,3.0V,40MA	01295	TIL 209A
DS40208	150-1036-00			LAMP,LED:RED,3.0V,40MA	01295	TIL 209A
DS40210	150-1036-00			LAMP,LED:RED,3.0V,40MA	01295	TIL 209A
DS40214	150-1036-00			LAMP,LED:RED,3.0V,40MA	01295	TIL 209A
DS40220	150-1036-00			LAMP,LED:RED,3.0V,40MA	01295	TIL 209A

Replaceable Electrical Parts—7A16P

Ckt No.	Tektronix Part No.	Serial/Model No.		Name & Description	Mfr Code	Mfr Part Number
		Eff	Dscont			
DS40400	150-1036-00			LAMP,LED:RED,3.0V,40MA	01295	TIL 209A
DS40410	150-1036-00			LAMP,LED:RED,3.0V,40MA	01295	TIL 209A
DS40500	150-1036-00			LAMP,LED:RED,3.0V,40MA	01295	TIL 209A
DS40508	150-1036-00			LAMP,LED:RED,3.0V,40MA	01295	TIL 209A
DS40510	150-1036-00			LAMP,LED:RED,3.0V,40MA	01295	TIL 209A
E000	276-0507-00			SHIELDING BEAD,:FERRITE	78488	57-3443
E010	276-0507-00			SHIELDING BEAD,:FERRITE	78488	57-3443
E30528	276-0507-00	B010100	B041606	SHIELDING BEAD,:FERRITE	78488	57-3443
J30120	131-1003-00			CONN,RCPT,ELEC:CKT BD MT,3 PRONG	80009	131-1003-00
J30125	131-1003-00			CONN,RCPT,ELEC:CKT BD MT,3 PRONG	80009	131-1003-00
J30138	131-1003-00			CONN,RCPT,ELEC:CKT BD MT,3 PRONG	80009	131-1003-00
J30140	131-1003-00			CONN,RCPT,ELEC:CKT BD MT,3 PRONG	80009	131-1003-00
J40100	131-1362-01			CONN,RCPT,ELEC:CKT CD,DBL ROW,15 CONTACTS	80009	131-1362-01
J60020	131-1003-00			CONN,RCPT,ELEC:CKT BD MT,3 PRONG	80009	131-1003-00
J60025	131-1003-00			CONN,RCPT,ELEC:CKT BD MT,3 PRONG	80009	131-1003-00
J60038	131-1003-00			CONN,RCPT,ELEC:CKT BD MT,3 PRONG	80009	131-1003-00
J60040	131-1003-00			CONN,RCPT,ELEC:CKT BD MT,3 PRONG	80009	131-1003-00
K10000	108-0891-00			COIL,RF:FIXED,REED SWITCH,4.6V	80009	108-0891-00
K10002	108-0891-00			COIL,RF:FIXED,REED SWITCH,4.6V	80009	108-0891-00
K10004	108-0891-00			COIL,RF:FIXED,REED SWITCH,4.6V	80009	108-0891-00
K10010	108-0891-00			COIL,RF:FIXED,REED SWITCH,4.6V	80009	108-0891-00
K10100	108-0891-00			COIL,RF:FIXED,REED SWITCH,4.6V	80009	108-0891-00
K10110	108-0891-00			COIL,RF:FIXED,REED SWITCH,4.6V	80009	108-0891-00
L60002	108-0311-00			COIL,RF:FIXED,153NH	80009	108-0311-00
L60020	108-0311-00			COIL,RF:FIXED,153NH	80009	108-0311-00
L60030	108-0311-00			COIL,RF:FIXED,153NH	80009	108-0311-00
L60050	108-0311-00			COIL,RF:FIXED,153NH	80009	108-0311-00
L60540	108-0420-00			COIL,RF:60NH	80009	108-0420-00
LR10007	108-0677-00			COIL,RF:57NH	80009	108-0677-00
LR60120	108-0184-00			COIL,RF:3.2UH(WOUND ON A 10 OHM RES	80009	108-0184-00
LR60122	108-0184-00			COIL,RF:3.2UH(WOUND ON A 10 OHM RES	80009	108-0184-00
LR301710	108-0537-00			COIL,RF:200UH	80009	108-0537-00
LR301714	108-0543-00			COIL,RF:FIXED,1.1UH	80009	108-0543-00
LR301720	108-0543-00			COIL,RF:FIXED,1.1UH	80009	108-0543-00
P60630	131-0608-00			TERMINAL,PIN:0.365 L X 0.025 PH BRZ GOLD	22526	47357
P60632	131-0608-00			TERMINAL,PIN:0.365 L X 0.025 PH BRZ GOLD	22526	47357
P60730	131-0608-00			TERMINAL,PIN:0.365 L X 0.025 PH BRZ GOLD	22526	47357
Q10100	151-1021-00			TRANSISTOR:SILICON,JFE	17856	FN815
Q10110	151-1021-00			TRANSISTOR:SILICON,JFE	17856	FN815
Q10200	151-1021-00			TRANSISTOR:SILICON,JFE	17856	FN815
Q10202	151-1021-00			TRANSISTOR:SILICON,JFE	17856	FN815
Q10204	151-1021-00			TRANSISTOR:SILICON,JFE	17856	FN815
Q10212	151-1025-00			TRANSISTOR:SILICON,JFE,N-CHANNEL	01295	SFB8129
Q10214	151-1025-00			TRANSISTOR:SILICON,JFE,N-CHANNEL	01295	SFB8129
Q10300	151-0441-00			TRANSISTOR:SILICON,NPN	04713	SRF501
Q10302	151-1103-00			TRANSISTOR:SILICON,FE,N-CHANNEL	18324	SD210EE
Q10303	151-1025-00			TRANSISTOR:SILICON,JFE,N-CHANNEL	01295	SFB8129

Ckt No.	Tektronix Part No.	Serial/Model No.		Name & Description	Mfr Code	Mfr Part Number
		Eff	Dscont			
Q10304	151-0447-00			TRANSISTOR:SILICON,NPN	04713	SRF502-1
Q10306	151-1021-00			TRANSISTOR:SILICON,JFE	17856	FN815
Q10308	151-1107-00			TRANSISTOR:SILICON,FET	80009	151-1107-00
Q10400	151-1021-00			TRANSISTOR:SILICON,JFE	17856	FN815
Q10402	151-1107-00			TRANSISTOR:SILICON,FET	80009	151-1107-00
Q30010	151-0188-00			TRANSISTOR:SILICON,PNP	04713	SPS6868K
Q30016	151-0188-00			TRANSISTOR:SILICON,PNP	04713	SPS6868K
Q30110	151-0188-00			TRANSISTOR:SILICON,PNP	04713	SPS6868K
Q30300	151-0190-00			TRANSISTOR:SILICON,NPN	07263	S032677
Q30308	151-0188-00			TRANSISTOR:SILICON,PNP	04713	SPS6868K
Q30400	151-0190-00			TRANSISTOR:SILICON,NPN	07263	S032677
Q30408	151-0188-00			TRANSISTOR:SILICON,PNP	04713	SPS6868K
Q30520	151-0190-00			TRANSISTOR:SILICON,NPN	07263	S032677
Q30528	151-0190-00	B010100	B041606	TRANSISTOR:SILICON,NPN	07263	S032677
Q30620	151-0188-00			TRANSISTOR:SILICON,PNP	04713	SPS6868K
Q30624	151-0188-00			TRANSISTOR:SILICON,PNP	04713	SPS6868K
Q60100	151-0221-00			TRANSISTOR:SILICON,PNP	04713	SPS246
Q60110	151-0271-00			TRANSISTOR:SILICON,PNP	04713	SPS8236
Q60112	151-0271-00			TRANSISTOR:SILICON,PNP	04713	SPS8236
Q60114	151-0221-00			TRANSISTOR:SILICON,PNP	04713	SPS246
Q60132	153-0606-00			SEMICON DVC,SE:MATCHED,6V,15MA	80009	153-0606-00
Q60140	153-0606-00			SEMICON DVC,SE:MATCHED,6V,15MA	80009	153-0606-00
Q60142	153-0606-00			SEMICON DVC,SE:MATCHED,6V,15MA	80009	153-0606-00
Q60144	153-0606-00			SEMICON DVC,SE:MATCHED,6V,15MA	80009	153-0606-00
Q60214	151-0341-00			TRANSISTOR:SILICON,NPN	07263	S040065
Q60320	151-0341-00			TRANSISTOR:SILICON,NPN	07263	S040065
Q60620	151-0188-00			TRANSISTOR:SILICON,PNP	04713	SPS6868K
Q60622	151-0188-00			TRANSISTOR:SILICON,PNP	04713	SPS6868K
Q60702	151-0188-00			TRANSISTOR:SILICON,PNP	04713	SPS6868K
Q60720	151-0188-00			TRANSISTOR:SILICON,PNP	04713	SPS6868K
Q60721	151-0188-00			TRANSISTOR:SILICON,PNP	04713	SPS6868K
Q60722	151-0188-00			TRANSISTOR:SILICON,PNP	04713	SPS6868K
Q60724	151-0188-00			TRANSISTOR:SILICON,PNP	04713	SPS6868K
Q60820	151-0342-00			TRANSISTOR:SILICON,PNP	07263	S035928
Q60822	151-0342-00			TRANSISTOR:SILICON,PNP	07263	S035928
Q60824	151-0342-00			TRANSISTOR:SILICON,PNP	07263	S035928
Q60900	151-0188-00			TRANSISTOR:SILICON,PNP	04713	SPS6868K
Q60920	151-0342-00			TRANSISTOR:SILICON,PNP	07263	S035928
Q60922	151-0342-00			TRANSISTOR:SILICON,PNP	07263	S035928
Q301230	151-0188-00			TRANSISTOR:SILICON,PNP	04713	SPS6868K
Q301300	151-0190-00			TRANSISTOR:SILICON,NPN	07263	S032677
Q301302	151-0190-00			TRANSISTOR:SILICON,NPN	07263	S032677
Q301400	151-0190-00			TRANSISTOR:SILICON,NPN	07263	S032677
Q301404	151-0342-00			TRANSISTOR:SILICON,PNP	07263	S035928
Q301410	151-0190-00			TRANSISTOR:SILICON,NPN	07263	S032677
Q301412	151-0342-00			TRANSISTOR:SILICON,PNP	07263	S035928
Q301414	151-0190-00			TRANSISTOR:SILICON,NPN	07263	S032677
Q301416	151-0342-00			TRANSISTOR:SILICON,PNP	07263	S035928
Q301510	151-0188-00			TRANSISTOR:SILICON,PNP	04713	SPS6868K
Q301512	151-0188-00			TRANSISTOR:SILICON,PNP	04713	SPS6868K
Q301515	151-0190-00			TRANSISTOR:SILICON,NPN	07263	S032677
RT10416	307-0343-00			RES.,THERMAL:200 OHM,10%	50157	40C20112

Replaceable Electrical Parts—7A16P

Ckt No.	Tektronix Part No.	Serial/Model No. Eff	Dscont	Name & Description	Mfr Code	Mfr Part Number
R10000	317-0102-00			RES.,FXD,CMPSN:1K OHM,5%,0.125W	01121	BB1025
R10002	321-0126-00			RES.,FXD,FILM:200 OHM,1%,0.125W	91637	MFF1816G200R0F
R10004	321-0126-00			RES.,FXD,FILM:200 OHM,1%,0.125W	91637	MFF1816G200R0F
R10008	317-0510-00			RES.,FXD,CMPSN:51 OHM,5%,0.125W	01121	BB5105
R10010	321-0126-00			RES.,FXD,FILM:200 OHM,1%,0.125W	91637	MFF1816G200R0F
R10012	321-0126-00			RES.,FXD,FILM:200 OHM,1%,0.125W	91637	MFF1816G200R0F
R10100	315-0330-00			RES.,FXD,CMPSN:33 OHM,5%,0.25W	01121	CB3305
R10102	317-0107-00			RES.,FXD,CMPSN:100M OHM,5%,0.125W	01121	BB1075
R10110	317-0107-00			RES.,FXD,CMPSN:100M OHM,5%,0.125W	01121	BB1075
R10112	317-0104-00	B041415		RES.,FXD,CMPSN:100K OHM,5%,0.125W	01121	BB1045
R10114	317-0107-00			RES.,FXD,CMPSN:100M OHM,5%,0.125W	01121	BB1075
R10200	317-0107-00			RES.,FXD,CMPSN:100M OHM,5%,0.125W	01121	BB1075
R10202	317-0107-00			RES.,FXD,CMPSN:100M OHM,5%,0.125W	01121	BB1075
R10204	321-0469-04			RES.,FXD,FILM:750K OHM,0.1%,0.125W	91637	MFF1816D75002B
R10206	317-0470-00			RES.,FXD,CMPSN:47 OHM,5%,0.125W	01121	BB4705
R10208	317-0107-00			RES.,FXD,CMPSN:100M OHM,5%,0.125W	01121	BB1075
R10209	317-0300-00			RES.,FXD,CMPSN:30 OHM,5%,0.125W	01121	BB3005
R10210	317-0107-00			RES.,FXD,CMPSN:100M OHM,5%,0.125W	01121	BB1075
R10216	321-0618-04			RES.,FXD,FILM:250K OHM,0.1%,0.125W	07716	OBD
R10218	317-0683-00			RES.,FXD,CMPSN:68K OHM,5%,0.125W	01121	BB6835
R10300	317-0471-00			RES.,FXD,CMPSN:470 OHM,5%,0.125W	01121	BB4715
R10301	317-0123-00			RES.,FXD,CMPSN:12K OHM,5%,0.125W	01121	BB1235
R10302	317-0107-00			RES.,FXD,CMPSN:100M OHM,5%,0.125W	01121	BB1075
R10303	317-0101-00			RES.,FXD,CMPSN:100 OHM,5%,0.125W	01121	BB1015
R10304	317-0103-00			RES.,FXD,CMPSN:10K OHM,5%,0.125W	01121	BB1035
R10306	317-0106-00			RES.,FXD,CMPSN:10M OHM,5%,0.125W	01121	BB1065
R10307	321-0440-00			RES.,FXD,FILM:374K OHM,1%,0.125W	91637	MFF1816G37402F
R10309	315-0102-00			RES.,FXD,CMPSN:1K OHM,5%,0.25W	01121	CB1025
R10312	321-0394-00			RES.,FXD,FILM:124K OHM,1%,0.125W	91637	MFF1816G12402F
R10315	311-1273-00			RES.,VAR,NONWIR:200K OHM,10%,0.5W	32997	3329P-L58-204
R10316	315-0100-00			RES.,FXD,CMPSN:10 OHM,5%,0.25W	01121	CB1005
R10317	311-1270-00			RES.,VAR,NONWIR:12K OHM,10%,0.5W	32997	3329P-L58-253
R10318	315-0300-00			RES.,FXD,CMPSN:30 OHM,5%,0.25W	01121	CB3005
R10319	315-0154-00			RES.,FXD,CMPSN:150K OHM,5%,0.25W	01121	CB1545
R10400	321-0147-00			RES.,FXD,FILM:332 OHM,1%,0.125W	91637	MFF1816G332R0F
R10401	315-0112-00			RES.,FXD,CMPSN:1.1K OHM,5%,0.25W	01121	CB1125
R10402	317-0106-00			RES.,FXD,CMPSN:10M OHM,5%,0.125W	01121	BB1065
R10404	321-0162-00			RES.,FXD,FILM:475 OHM,1%,0.125W	91637	MFF1816G475R0F
R10406	311-0643-00			RES.,VAR,NONWIR:50 OHM,10%,0.50W	73138	82-33-2
R10407	321-0126-00			RES.,FXD,FILM:200 OHM,0.1%,0.125W	91637	MFF1816C200ROB
R10410	317-0106-00			RES.,FXD,CMPSN:10M OHM,5%,0.125W	01121	BB1065
R10412	311-1273-00			RES.,VAR,NONWIR:200K OHM,10%,0.5W	32997	3329P-L58-204
R10413	317-0106-00			RES.,FXD,CMPSN:10M OHM,5%,0.125W	01121	BB1065
R10414	311-1269-00			RES.,VAR,NONWIR:20K OHM,10%,0.50W	32997	3329P-L58-203
R10416	315-0101-00			RES.,FXD,CMPSN:100 OHM,5%,0.25W	01121	CB1015
R10418	315-0154-00			RES.,FXD,CMPSN:150K OHM,5%,0.25W	01121	CB1545
R20106	315-0103-00			RES.,FXD,CMPSN:10K OHM,5%,0.25W	01121	CB1035
R20212	315-0103-00			RES.,FXD,CMPSN:10K OHM,5%,0.25W	01121	CB1035
R30010	321-0239-00			RES.,FXD,FILM:3.01K OHM,1%,0.125W	91637	MFF1816G30100F
R30012	315-0103-00			RES.,FXD,CMPSN:10K OHM,5%,0.25W	01121	CB1035
R30020	321-0187-00			RES.,FXD,FILM:866 OHM,1%,0.125W	91637	MFF1816G866R0F
R30022	321-0195-00			RES.,FXD,FILM:1.05K OHM,1%,0.125W	91637	MFF1816G10500F
R30108	315-0103-00			RES.,FXD,CMPSN:10K OHM,5%,0.25W	01121	CB1035
R30110	315-0121-00			RES.,FXD,CMPSN:120 OHM,5%,0.25W	01121	CB1215

Ckt No.	Tektronix Part No.	Serial/Model No.		Name & Description	Mfr Code	Mfr Part Number
		Eff	Dscont			
R30112	315-0103-00			RES.,FXD,CMPSN:10K OHM,5%,0.25W	01121	CB1035
R30114	315-0103-00			RES.,FXD,CMPSN:10K OHM,5%,0.25W	01121	CB1035
R30115	315-0103-00			RES.,FXD,CMPSN:10K OHM,5%,0.25W	01121	CB1035
R30122	315-0221-00			RES.,FXD,CMPSN:220 OHM,5%,0.25W	01121	CB2215
R30124	321-0152-00			RES.,FXD,FILM:374 OHM,1%,0.125W	91637	MFF1816G374R0F
R30125	315-0680-00			RES.,FXD,CMPSN:68 OHM,5%,0.25W	01121	CB6805
R30126	315-0363-00			RES.,FXD,CMPSN:36K OHM,5%,0.25W	01121	CB3635
R30128	321-0126-00			RES.,FXD,FILM:200 OHM,1%,0.125W	91637	MFF1816G200R0F
R30200	311-1853-00			RES.,VAR,NONWIR:2.5K OHM,10%,0.50W	01121	18M838
R30210	321-0302-00			RES.,FXD,FILM:13.7K OHM,1%,0.125W	91637	MFF1816G13701F
R30212	315-0274-00			RES.,FXD,CMPSN:270K OHM,5%,0.25W	01121	CB2745
R30214	315-0103-00			RES.,FXD,CMPSN:10K OHM,5%,0.25W	01121	CB1035
R30220	315-0103-00			RES.,FXD,CMPSN:10K OHM,5%,0.25W	01121	CB1035
R30224	321-0378-00	B010100	B029999	RES.,FXD,FILM:84.5K OHM,1%,0.125W	91637	MFF1816G84501F
R30224	321-0358-00	B030000	B041606	RES.,FXD,FILM:52.3K OHM,1%,0.125W	91637	MFF1816G52301F
R30226	321-0334-00	B010100	B029999	RES.,FXD,FILM:29.4K OHM,1%,0.125W	91637	MFF1816G29401F
R30226	321-0366-00	B030000	B041606	RES.,FXD,FILM:63.4K OHM,1%,0.125W	91637	MFF1816G63401F
R30228	315-0681-00	B010100	B029999	RES.,FXD,CMPSN:680 OHM,5%,0.25W	01121	CB6815
R30228	315-0202-00	B030000		RES.,FXD,CMPSN:2K OHM,5%,0.25W	01121	CB2025
R30300	315-0104-00			RES.,FXD,CMPSN:100K OHM,5%,0.25W	01121	CB1045
R30304	315-0104-00			RES.,FXD,CMPSN:100K OHM,5%,0.25W	01121	CB1045
R30306	321-0212-00			RES.,FXD,FILM:1.58K OHM,1%,0.125W	91637	MFF1816G15800F
R30310	321-0212-00			RES.,FXD,FILM:1.58K OHM,1%,0.125W	91637	MFF1816G15800F
R30312	321-0270-00			RES.,FXD,FILM:6.34K OHM,1%,0.125W	91637	MFF1816G63400F
R30314	321-0270-00			RES.,FXD,FILM:6.34K OHM,1%,0.125W	91637	MFF1816G63400F
R30316	321-0354-00			RES.,FXD,FILM:47.5K OHM,1%,0.125W	91637	MFF1816G47501F
R30320	321-0341-00	B010100	B029999	RES.,FXD,FILM:34.8K OHM,1%,0.125W	91637	MFF1816G34801F
R30320	321-0233-00	B030000		RES.,FXD,FILM:2.61K OHM,1%,0.125W	91637	MFF1816G26100F
R30322	315-0222-00			RES.,FXD,CMPSN:2.2K OHM,5%,0.25W	01121	CB2225
R30324	321-0324-00	B010100	B029999	RES.,FXD,FILM:23.2K OHM,1%,0.125W	91637	MFF1816G23201F
R30324	321-0329-00	B030000	B041606	RES.,FXD,FILM:26.1K OHM,1%,0.125W	91637	MFF1816G26101F
R30326	321-0705-00	B010100	B029999	RES.,FXD,FILM:41.7K OHM,1%,0.125W	91637	MFF1816G41701F
R30326	321-0325-00	B030000	B041606	RES.,FXD,FILM:23.7K OHM,1%,0.125W	91637	MFF1816G23701F
R30328	311-1268-00			RES.,VAR,NONWIR:10K OHM,10%,0.50W	32997	3329P-L58-103
R30404	321-0273-00			RES.,FXD,FILM:6.81K OHM,1%,0.125W	91637	MFF1816G68100F
R30406	321-0181-00			RES.,FXD,FILM:750 OHM,1%,0.125W	91637	MFF1816G750R0F
R30420	315-0104-00			RES.,FXD,CMPSN:100K OHM,5%,0.25W	01121	CB1045
R30422	315-0331-00			RES.,FXD,CMPSN:330 OHM,5%,0.25W	01121	CB3315
R30504	315-0103-00			RES.,FXD,CMPSN:10K OHM,5%,0.25W	01121	CB1035
R30514	311-1268-00			RES.,VAR,NONWIR:10K OHM,10%,0.50W	32997	3329P-L58-103
R30520	315-0222-00			RES.,FXD,CMPSN:2.2K OHM,5%,0.25W	01121	CB2225
R30522	315-0102-00			RES.,FXD,CMPSN:1K OHM,5%,0.25W	01121	CB1025
R30524	315-0103-00			RES.,FXD,CMPSN:10K OHM,5%,0.25W	01121	CB1035
R30526	315-0102-00			RES.,FXD,CMPSN:1K OHM,5%,0.25W	01121	CB1025
R30530	315-0102-00	B010100	B010189	RES.,FXD,CMPSN:1K OHM,5%,0.25W	01121	CB1025
R30530	315-0331-00	B010190	B041606	RES.,FXD,CMPSN:330 OHM,5%,0.25W	01121	CB3315
R30534	315-0472-00			RES.,FXD,CMPSN:4.7K OHM,5%,0.25W	01121	CB4725
R30620	315-0221-00			RES.,FXD,CMPSN:220 OHM,5%,0.25W	01121	CB2215
R30622	315-0102-00			RES.,FXD,CMPSN:1K OHM,5%,0.25W	01121	CB1025
R30623	315-0220-00			RES.,FXD,CMPSN:22 OHM,5%,0.25W	01121	CB2205
R30624	315-0220-00			RES.,FXD,CMPSN:22 OHM,5%,0.25W	01121	CB2205
R30625	315-0221-00			RES.,FXD,CMPSN:220 OHM,5%,0.25W	01121	CB2215
R30626	315-0102-00			RES.,FXD,CMPSN:1K OHM,5%,0.25W	01121	CB1025
R30628	321-1231-01			RES.,FXD,FILM:2.52K OHM,0.5%,0.125W	91637	MFF1816G25200D

Replaceable Electrical Parts—7A16P

Ckt No.	Tektronix	Serial/Model No.		Name & Description	Mfr	Mfr Part Number
	Part No.	Eff	Dscont		Code	
R30710	321-0289-00			RES.,FXD.FILM:10K OHM,1%,0.125W	91637	MFF1816G10001F
R30800	315-0103-00			RES.,FXD.CMPSN:10K OHM,5%,0.25W	01121	CB1035
R30810	315-0103-00			RES.,FXD.CMPSN:10K OHM,5%,0.25W	01121	CB1035
R30812	321-0277-03			RES.,FXD.FILM:7.5K OHM,0.25%,0.125W	24546	NC55C7501C
R40020	311-1845-00			RES.,VAR.NONWIR:PNL,5K OHM,0.50W	01121	W8355
R40218	315-0131-00			RES.,FXD.CMPSN:130 OHM,5%,0.25W	01121	CB1315
R40220	315-0131-00			RES.,FXD.CMPSN:130 OHM,5%,0.25W	01121	CB1315
R40300	311-1954-00			RES.,VAR.NONWIR:CKT BD,1K OHM,20%,0.25W	12697	CM41724
R40402	315-0131-00			RES.,FXD.CMPSN:130 OHM,5%,0.25W	01121	CB1315
R40406	315-0131-00			RES.,FXD.CMPSN:130 OHM,5%,0.25W	01121	CB1315
R40408	315-0131-00			RES.,FXD.CMPSN:130 OHM,5%,0.25W	01121	CB1315
R60000	323-0212-00			RES.,FXD.FILM:1.58 OHM,1%,0.50W	75042	CECT0-1581F
R60004	315-0470-00			RES.,FXD.CMPSN:47 OHM,5%,0.25W	01121	CB4705
R60006	315-0431-00			RES.,FXD.CMPSN:430 OHM,5%,0.25W	01121	CB4315
R60010	315-0111-00			RES.,FXD.CMPSN:110 OHM,5%,0.25W	01121	CB1115
R60014	315-0431-00			RES.,FXD.CMPSN:430 OHM,5%,0.25W	01121	CB4315
R60016	315-0470-00			RES.,FXD.CMPSN:47 OHM,5%,0.25W	01121	CB4705
R60020	323-0212-00			RES.,FXD.FILM:1.58 OHM,1%,0.50W	75042	CECT0-1581F
R60030	323-0193-00			RES.,FXD.FILM:1K OHM,1%,0.50W	75042	CECT0-1001F
R60032	315-0470-00			RES.,FXD.CMPSN:47 OHM,5%,0.25W	01121	CB4705
R60034	315-0431-00			RES.,FXD.CMPSN:430 OHM,5%,0.25W	01121	CB4315
R60040	315-0111-00			RES.,FXD.CMPSN:110 OHM,5%,0.25W	01121	CB1115
R60046	315-0431-00			RES.,FXD.CMPSN:430 OHM,5%,0.25W	01121	CB4315
R60048	315-0470-00			RES.,FXD.CMPSN:47 OHM,5%,0.25W	01121	CB4705
R60050	323-0193-00			RES.,FXD.FILM:1K OHM,1%,0.50W	75042	CECT0-1001F
R60100	308-0304-00			RES.,FXD.WW:1.5K OHM,1%,3W	91637	RS2B-B15000F
R60102	315-0101-00			RES.,FXD.CMPSN:100 OHM,5%,0.25W	01121	CB1015
R60104	315-0101-00			RES.,FXD.CMPSN:100 OHM,5%,0.25W	01121	CB1015
R60110	315-0560-00			RES.,FXD.CMPSN:56 OHM,5%,0.25W	01121	CB5605
R60112	315-0560-00			RES.,FXD.CMPSN:56 OHM,5%,0.25W	01121	CB5605
R60114	315-0101-00			RES.,FXD.CMPSN:100 OHM,5%,0.25W	01121	CB1015
R60116	315-0101-00			RES.,FXD.CMPSN:100 OHM,5%,0.25W	01121	CB1015
R60120	308-0304-00			RES.,FXD.WW:1.5K OHM,1%,3W	91637	RS2B-B15000F
R60130	308-0406-00			RES.,FXD.WW:1.2K OHM,1%,3W	56289	242EX1K200FQ18
R60132	315-0101-00			RES.,FXD.CMPSN:100 OHM,5%,0.25W	01121	CB1015
R60134	315-0101-00			RES.,FXD.CMPSN:100 OHM,5%,0.25W	01121	CB1015
R60136	315-0101-00			RES.,FXD.CMPSN:100 OHM,5%,0.25W	01121	CB1015
R60137	311-1268-00			RES.,VAR.NONWIR:10K OHM,10%,0.50W	32997	3329P-L58-103
R60138	311-1259-00			RES.,VAR.NONWIR:100 OHM,10%,0.50W	32997	3329P-L58-101
R60140	315-0560-00			RES.,FXD.CMPSN:56 OHM,5%,0.25W	01121	CB5605
R60142	315-0560-00			RES.,FXD.CMPSN:56 OHM,5%,0.25W	01121	CB5605
R60143	315-0432-00			RES.,FXD.CMPSN:4.3K OHM,5%,0.25W	01121	CB4325
R60148	315-0101-00			RES.,FXD.CMPSN:100 OHM,5%,0.25W	01121	CB1015
R60150	308-0406-00			RES.,FXD.WW:1.2K OHM,1%,3W	56289	242EX1K200FQ18
R60202	315-0513-00			RES.,FXD.CMPSN:51K OHM,5%,0.25W	01121	CB5135
R60212	321-0194-00			RES.,FXD.FILM:1.02K OHM,1%,0.125W	91637	MFF1816G10200F
R60214	321-0278-00			RES.,FXD.FILM:7.68K OHM,1%,0.125W	91637	MFF1816G76800F
R60215	321-0237-00			RES.,FXD.FILM:2.87K OHM,1%,0.125W	91637	MFF1816G28700F
R60220	308-0552-00			RES.,FXD.WW:750 OHM,1%,3W	14193	SA30 750 OHM
R60222	308-0552-00			RES.,FXD.WW:750 OHM,1%,3W	14193	SA30 750 OHM
R60224	323-0629-00			RES.,FXD.FILM:43.1 OHM,1%,0.5W	91637	MFF1226G43A10F
R60230	315-0102-00			RES.,FXD.CMPSN:1K OHM,5%,0.25W	01121	CB1025
R60234	315-0102-00			RES.,FXD.CMPSN:1K OHM,5%,0.25W	01121	CB1025
R60235	315-0151-00			RES.,FXD.CMPSN:150 OHM,5%,0.25W	01121	CB1515

Ckt No.	Tektronix	Serial/Model No.		Name & Description	Mfr	Mfr Part Number
	Part No.	Eff	Dscont		Code	
R60237	321-0069-00			RES.,FXD,FILM:51.1 OHM,1%,0.125W	91637	MFF1816G51R10F
R60238	315-0151-00			RES.,FXD,CMPSN:150 OHM,5%,0.25W	01121	CB1515
R60240	315-0122-00			RES.,FXD,CMPSN:1.2K OHM,5%,0.25W	01121	CB1225
R60242	321-0069-00			RES.,FXD,FILM:51.1 OHM,1%,0.125W	91637	MFF1816G51R10F
R60250	315-0751-00			RES.,FXD,CMPSN:750 OHM,5%,0.25W	01121	CB7515
R60252	315-0751-00			RES.,FXD,CMPSN:750 OHM,5%,0.25W	01121	CB7515
R60302	311-1231-00			RES.,VAR,NONWIR:25K OHM,20%,0.50W	32997	3386F-T04-253
R60304	311-1225-00			RES.,VAR,NONWIR:1K OHM,20%,0.50W	32997	3386F-T04-103
R60310	321-0110-00			RES.,FXD,FILM:137 OHM,1%,0.125W	91637	MFF1816G137R0F
R60312	323-0182-00			RES.,FXD,FILM:768 OHM,1%,0.50W	91637	MFF1226G768R0F
R60314	315-0751-00			RES.,FXD,CMPSN:750 OHM,5%,0.25W	01121	CB7515
R60315	315-0364-00			RES.,FXD,CMPSN:360K OHM,5%,0.25W	01121	CB3645
R60316	315-0152-00			RES.,FXD,CMPSN:1.5K OHM,5%,0.25W	01121	CB1525
R60318	311-1228-00			RES.,VAR,NONWIR:10K OHM,20%,0.50W	32997	3386F-T04-103
R60326	315-0822-00			RES.,FXD,CMPSN:8.2K OHM,5%,0.25W	01121	CB8225
R60330	315-0111-00			RES.,FXD,CMPSN:110 OHM,5%,0.25W	01121	CB1115
R60332	311-1261-00			RES.,VAR,NONWIR:500 OHM,10%,0.50W	32997	3329P-L58-501
R60333	323-0166-00	B010167	B041593	RES.,FXD,FILM:523 OHM,1%,0.50W	75042	CECT0-5230F
R60333	323-0149-00	B041594		RES.,FXD,FILM:348 OHM,1%,0.50W	75042	CECT0-3480F
R60334	323-0178-00	B010100	B010166	RES.,FXD,FILM:698 OHM,1%,0.50W	91637	MFF1226G698R0F
R60334	321-0120-00	B010167	B041593	RES.,FXD,FILM:174 OHM,1%,0.125W	91637	MFF1816G174R0F
R60334	323-0149-00	B041594		RES.,FXD,FILM:348 OHM,1%,0.50W	75042	CECT0-3480F
R60335	323-0166-00	B010167	B041593	RES.,FXD,FILM:523 OHM,1%,0.50W	75042	CECT0-5230F
R60335	323-0149-00	B041594		RES.,FXD,FILM:348 OHM,1%,0.50W	75042	CECT0-3480F
R60336	323-0178-00	B010100	B010166	RES.,FXD,FILM:698 OHM,1%,0.50W	91637	MFF1226G698R0F
R60336	321-0120-00	B010167	B041593	RES.,FXD,FILM:174 OHM,1%,0.125W	91637	MFF1816G174R0F
R60336	323-0149-00	B041594		RES.,FXD,FILM:348 OHM,1%,0.50W	75042	CECT0-3480F
R60337	315-0111-00			RES.,FXD,CMPSN:110 OHM,5%,0.25W	01121	CB1115
R60338	323-0123-00			RES.,FXD,FILM:187 OHM,1%,0.50W	91637	MFF1226G187R0F
R60339	315-0272-00			RES.,FXD,CMPSN:2.7K OHM,5%,0.25W	01121	CB2725
R60340	321-0069-00			RES.,FXD,FILM:51.1 OHM,1%,0.125W	91637	MFF1816G51R10F
R60342	321-0069-00			RES.,FXD,FILM:51.1 OHM,1%,0.125W	91637	MFF1816G51R10F
R60350	321-0195-00			RES.,FXD,FILM:1.05K OHM,1%,0.125W	91637	MFF1816G10500F
R60354	321-0255-00			RES.,FXD,FILM:4.42K OHM,1%,0.125W	91637	MFF1816G44200F
R60355	321-0024-00			RES.,FXD,FILM:17.4 OHM,1%,0.125W	91637	MFF1816G174R0F
R60359	315-0302-00			RES.,FXD,CMPSN:3K OHM,5%,0.25W	01121	CB3025
R60410	315-0161-00			RES.,FXD,CMPSN:160 OHM,5%,0.25W	01121	CB1615
R60416	315-0102-00			RES.,FXD,CMPSN:1K OHM,5%,0.25W	01121	CB1025
R60418	311-1228-00			RES.,VAR,NONWIR:10K OHM,20%,0.50W	32997	3386F-T04-103
R60422	311-1269-00			RES.,VAR,NONWIR:20K OHM,10%,0.50W	32997	3329P-L58-203
R60424	315-0822-00			RES.,FXD,CMPSN:8.2K OHM,5%,0.25W	01121	CB8225
R60430	315-0101-00			RES.,FXD,CMPSN:100 OHM,5%,0.25W	01121	CB1015
R60432	315-0102-00			RES.,FXD,CMPSN:1K OHM,5%,0.25W	01121	CB1025
R60434	323-0184-00			RES.,FXD,FILM:806 OHM,1%,0.50W	91637	MFF1226G806R0F
R60435	323-0184-00			RES.,FXD,FILM:806 OHM,1%,0.50W	91637	MFF1226G806R0F
R60436	315-0331-00			RES.,FXD,CMPSN:330 OHM,5%,0.25W	01121	CB3315
R60437	311-1259-00			RES.,VAR,NONWIR:100 OHM,10%,0.50W	32997	3329P-L58-101
R60438	315-0101-00			RES.,FXD,CMPSN:100 OHM,5%,0.25W	01121	CB1015
R60440	321-0069-00			RES.,FXD,FILM:51.1 OHM,1%,0.125W	91637	MFF1816G51R10F
R60442	321-0069-00			RES.,FXD,FILM:51.1 OHM,1%,0.125W	91637	MFF1816G51R10F
R60443	315-0681-00			RES.,FXD,CMPSN:680 OHM,5%,0.25W	01121	CB6815
R60446	311-1263-00			RES.,VAR,NONWIR:1K OHM,10%,0.50W	32997	3329P-L58-102
R60448	321-0080-00			RES.,FXD,FILM:66.5 OHM,1%,0.125W	91637	MFF1816G66R50F
R60449	321-0080-00			RES.,FXD,FILM:66.5 OHM,1%,0.125W	91637	MFF1816G66R50F

Replaceable Electrical Parts—7A16P

Ckt No.	Tektronix Part No.	Serial/Model No.		Name & Description	Mfr Code	Mfr Part Number
		Eff	Dscont			
R60452	315-0302-00			RES.,FXD,CMPSN:3K OHM,5%,0.25W	01121	CB3025
R60454	315-0271-00			RES.,FXD,CMPSN:270 OHM,5%,0.25W	01121	CB2715
R60456	315-0202-00			RES.,FXD,CMPSN:2K OHM,5%,0.25W	01121	CB2025
R60458	311-1226-00			RES.,VAR,NONWIR:2.5K OHM,20%,0.50W	32997	3386F-T04-252
R60520	315-0100-00			RES.,FXD,CMPSN:10 OHM,5%,0.25W	01121	CB1005
R60522	315-0682-00			RES.,FXD,CMPSN:6.8K OHM,5%,0.25W	01121	CB6825
R60524	315-0202-00			RES.,FXD,CMPSN:2K OHM,5%,0.25W	01121	CB2025
R60526	315-0100-00			RES.,FXD,CMPSN:10 OHM,5%,0.25W	01121	CB1005
R60528	315-0201-00			RES.,FXD,CMPSN:200 OHM,5%,0.25W	01121	CB2015
R60530	315-0822-00			RES.,FXD,CMPSN:8.2K OHM,5%,0.25W	01121	CB8225
R60532	315-0822-00			RES.,FXD,CMPSN:8.2K OHM,5%,0.25W	01121	CB8225
R60533	315-0330-00			RES.,FXD,CMPSN:33 OHM,5%,0.25W	01121	CB3305
R60534	323-0187-00			RES.,FXD,FILM:866 OHM,1%,0.50W	75042	CECT0-8660F
R60535	315-0330-00			RES.,FXD,CMPSN:33 OHM,5%,0.25W	01121	CB3305
R60536	323-0187-00			RES.,FXD,FILM:866 OHM,1%,0.50W	75042	CECT0-8660F
R60540	311-1260-00			RES.,VAR,NONWIR:250 OHM,10%,0.50W	32997	3329P-L58-251
R60550	321-0045-00			RES.,FXD,FILM:28.7 OHM,1%,0.125W	91637	MFF1816G28R70F
R60552	317-0101-00			RES.,FXD,CMPSN:100 OHM,5%,0.125W	01121	BB1015
R60554	317-0101-00			RES.,FXD,CMPSN:100 OHM,5%,0.125W	01121	BB1015
R60556	315-0681-00			RES.,FXD,CMPSN:680 OHM,5%,0.25W	01121	CB6815
R60558	315-0681-00			RES.,FXD,CMPSN:680 OHM,5%,0.25W	01121	CB6815
R60616	315-0102-00			RES.,FXD,CMPSN:1K OHM,5%,0.25W	01121	CB1025
R60620	315-0102-00			RES.,FXD,CMPSN:1K OHM,5%,0.25W	01121	CB1025
R60622	315-0102-00			RES.,FXD,CMPSN:1K OHM,5%,0.25W	01121	CB1025
R60700	315-0432-00			RES.,FXD,CMPSN:4.3K OHM,5%,0.25W	01121	CB4325
R60701	321-0156-00			RES.,FXD,FILM:412 OHM,1%,0.125W	91637	MFF1816G412R0F
R60702	321-0216-00			RES.,FXD,FILM:1.74K OHM,1%,0.125W	91637	MFF1816G17400F
R60704	315-0202-00			RES.,FXD,CMPSN:2K OHM,5%,0.25W	01121	CB2025
R60706	315-0203-00			RES.,FXD,CMPSN:20K OHM,5%,0.25W	01121	CB2035
R60716	315-0102-00			RES.,FXD,CMPSN:1K OHM,5%,0.25W	01121	CB1025
R60720	315-0102-00			RES.,FXD,CMPSN:1K OHM,5%,0.25W	01121	CB1025
R60722	315-0102-00			RES.,FXD,CMPSN:1K OHM,5%,0.25W	01121	CB1025
R60724	307-0541-00			RES,NTWK,THK FI:(7)1K OHM,10%,1W	91637	MSP08A01-102G
R60729	315-0513-00			RES.,FXD,CMPSN:51K OHM,5%,0.25W	01121	CB5135
R60800	321-0156-00			RES.,FXD,FILM:412 OHM,1%,0.125W	91637	MFF1816G412R0F
R60802	321-0216-00			RES.,FXD,FILM:1.74K OHM,1%,0.125W	91637	MFF1816G17400F
R60820	315-0104-00			RES.,FXD,CMPSN:100K OHM,5%,0.25W	01121	CB1045
R60821	315-0472-00			RES.,FXD,CMPSN:4.7K OHM,5%,0.25W	01121	CB4725
R60822	315-0513-00			RES.,FXD,CMPSN:51K OHM,5%,0.25W	01121	CB5135
R60823	315-0104-00			RES.,FXD,CMPSN:100K OHM,5%,0.25W	01121	CB1045
R60824	315-0472-00			RES.,FXD,CMPSN:4.7K OHM,5%,0.25W	01121	CB4725
R60825	315-0513-00			RES.,FXD,CMPSN:51K OHM,5%,0.25W	01121	CB5135
R60826	315-0104-00			RES.,FXD,CMPSN:100K OHM,5%,0.25W	01121	CB1045
R60827	315-0472-00			RES.,FXD,CMPSN:4.7K OHM,5%,0.25W	01121	CB4725
R60900	315-0202-00			RES.,FXD,CMPSN:2K OHM,5%,0.25W	01121	CB2025
R60902	315-0203-00			RES.,FXD,CMPSN:20K OHM,5%,0.25W	01121	CB2035
R60904	315-0332-00			RES.,FXD,CMPSN:3.3K OHM,5%,0.25W	01121	CB3325
R60920	315-0513-00			RES.,FXD,CMPSN:51K OHM,5%,0.25W	01121	CB5135
R60922	315-0104-00			RES.,FXD,CMPSN:100K OHM,5%,0.25W	01121	CB1045
R60924	315-0472-00			RES.,FXD,CMPSN:4.7K OHM,5%,0.25W	01121	CB4725
R60925	315-0513-00			RES.,FXD,CMPSN:51K OHM,5%,0.25W	01121	CB5135
R60926	315-0104-00			RES.,FXD,CMPSN:100K OHM,5%,0.25W	01121	CB1045
R60928	315-0472-00			RES.,FXD,CMPSN:4.7K OHM,5%,0.25W	01121	CB4725
R301230	315-0122-00			RES.,FXD,CMPSN:1.2K OHM,5%,0.25W	01121	CB1225

Ckt No.	Tektronix		Serial/Model No.		Name & Description	Mfr	
	Part No.	Eff	Dscont			Code	Mfr Part Number
R301234	315-0103-00				RES.,FXD,CMPSN:10K OHM,5%,0.25W	01121	CB1035
R301236	315-0104-00				RES.,FXD,CMPSN:100K OHM,5%,0.25W	01121	CB1045
R301300	315-0105-00				RES.,FXD,CMPSN:1M OHM,5%,0.25W	01121	CB1055
R301302	315-0154-00				RES.,FXD,CMPSN:150K OHM,5%,0.25W	01121	CB1545
R301304	315-0154-00				RES.,FXD,CMPSN:150K OHM,5%,0.25W	01121	CB1545
R301306	315-0105-00				RES.,FXD,CMPSN:1M OHM,5%,0.25W	01121	CB1055
R301308	315-0753-00				RES.,FXD,CMPSN:75K OHM,5%,0.25W	01121	CB7535
R301309	315-0753-00				RES.,FXD,CMPSN:75K OHM,5%,0.25W	01121	CB7535
R301310	321-0344-00				RES.,FXD,FILM:37.4K OHM,1%,0.125W	91637	MFF1816G37401F
R301330	315-0203-00				RES.,FXD,CMPSN:20K OHM,5%,0.25W	01121	CB2035
R301400	315-0753-00				RES.,FXD,CMPSN:75K OHM,5%,0.25W	01121	CB7535
R301402	315-0103-00				RES.,FXD,CMPSN:10K OHM,5%,0.25W	01121	CB1035
R301404	315-0513-00				RES.,FXD,CMPSN:51K OHM,5%,0.25W	01121	CB5135
R301406	315-0392-00				RES.,FXD,CMPSN:3.9K OHM,5%,0.25W	01121	CB3925
R301410	315-0103-00				RES.,FXD,CMPSN:10K OHM,5%,0.25W	01121	CB1035
R301411	315-0154-00				RES.,FXD,CMPSN:150K OHM,5%,0.25W	01121	CB1545
R301412	315-0392-00				RES.,FXD,CMPSN:3.9K OHM,5%,0.25W	01121	CB3925
R301414	315-0103-00				RES.,FXD,CMPSN:10K OHM,5%,0.25W	01121	CB1035
R301416	315-0392-00				RES.,FXD,CMPSN:3.9K OHM,5%,0.25W	01121	CB3925
R301420	315-0103-00				RES.,FXD,CMPSN:10K OHM,5%,0.25W	01121	CB1035
R301430	315-0101-00				RES.,FXD,CMPSN:100 OHM,5%,0.25W	01121	CB1015
R301432	315-0752-00	B010100	B030664		RES.,FXD,CMPSN:7.5K OHM,5%,0.25W	01121	CB7525
R301432	315-0103-00	B030665			RES.,FXD,CMPSN:10K OHM,5%,0.25W	01121	CB1035
R301510	315-0472-00				RES.,FXD,CMPSN:4.7K OHM,5%,0.25W	01121	CB4725
R301515	315-0222-00				RES.,FXD,CMPSN:2.2K OHM,5%,0.25W	01121	CB2225
R301520	315-0103-00				RES.,FXD,CMPSN:10K OHM,5%,0.25W	01121	CB1035
R301602	321-0193-00	B010100	B041606		RES.,FXD,FILM:1K OHM,1%,0.125W	91637	MFF1816G10000F
R301604	321-0218-00	B010100	B041606		RES.,FXD,FILM:1.82K OHM,1%,0.125W	91637	MFF1816G18200F
R301610	315-0103-00				RES.,FXD,CMPSN:10K OHM,5%,0.25W	01121	CB1035
R301612	315-0102-00				RES.,FXD,CMPSN:1K OHM,5%,0.25W	01121	CB1025
R301630	315-0102-00				RES.,FXD,CMPSN:1K OHM,5%,0.25W	01121	CB1025
RT60238	307-0125-00				RES.,THERMAL:500 OHM,10%,25 DEG C	50157	2D1595
RT60526	307-0127-00				RES.,THERMAL:1K OHM,10%	50157	2D1596
S10000	260-1237-00				SWITCH,REED:SPST	95348	MR-455-MODIFIED
S10002	260-1237-00				SWITCH,REED:SPST	95348	MR-455-MODIFIED
S10004	260-1237-00				SWITCH,REED:SPST	95348	MR-455-MODIFIED
S10010	260-1237-00				SWITCH,REED:SPST	95348	MR-455-MODIFIED
S10100	260-1237-00				SWITCH,REED:SPST	95348	MR-455-MODIFIED
S10110	260-1237-00				SWITCH,REED:SPST	95348	MR-455-MODIFIED
S30004	131-0604-00				CONTACT,ELEC:CKT BD SW,SPR,CU BE	80009	131-0604-00
S50100	263-0020-00				SWITCH,PB ASSY:MOMENTARY	80009	263-0020-00
S50108	263-0020-00				SWITCH,PB ASSY:MOMENTARY	80009	263-0020-00
S50110	263-0020-00				SWITCH,PB ASSY:MOMENTARY	80009	263-0020-00
S50120	263-0020-00				SWITCH,PB ASSY:MOMENTARY	80009	263-0020-00
S50200	263-0020-00				SWITCH,PB ASSY:MOMENTARY	80009	263-0020-00
S50202	263-0020-00				SWITCH,PB ASSY:MOMENTARY	80009	263-0020-00
S50206	263-0020-00				SWITCH,PB ASSY:MOMENTARY	80009	263-0020-00
S50208	263-0020-00				SWITCH,PB ASSY:MOMENTARY	80009	263-0020-00
S50210	263-0020-00				SWITCH,PB ASSY:MOMENTARY	80009	263-0020-00
S50214	263-0020-00				SWITCH,PB ASSY:MOMENTARY	80009	263-0020-00
S50220	263-0020-00				SWITCH,PB ASSY:MOMENTARY	80009	263-0020-00
S50400	263-0020-00				SWITCH,PB ASSY:MOMENTARY	80009	263-0020-00

Replaceable Electrical Parts—7A16P

Ckt No.	Tektronix Part No.	Serial/Model No.		Name & Description	Mfr Code	Mfr Part Number
		Eff	Dscont			
S50410	263-0020-00			SWITCH,PB ASSY:MOMENTARY	80009	263-0020-00
S50500	263-0020-00			SWITCH,PB ASSY:MOMENTARY	80009	263-0020-00
S50508	263-0020-00			SWITCH,PB ASSY:MOMENTARY	80009	263-0020-00
S50510	263-0020-00			SWITCH,PB ASSY:MOMENTARY	80009	263-0020-00
T10418	120-0286-00			XFMR,TOROID:2 TURNS,BIFILAR	80009	120-0286-00
U10310	156-0854-00			MICROCIRCUIT,LI:OPERATIONAL AMPLIFIER	27014	LM308AN
U30020	156-0466-02			MICROCIRCUIT,DI:QUAD 2-INP NAND BFR	01295	SN74LS37
U30120	156-0411-00			MICROCIRCUIT,LI:QUAD-COMP,SGL SUPPLY	27014	LM339N
U30210	156-0466-02			MICROCIRCUIT,DI:QUAD 2-INP NAND BFR	01295	SN74LS37
U30220	156-0411-00			MICROCIRCUIT,LI:QUAD-COMP,SGL SUPPLY	27014	LM339N
U30410	156-0093-02			MICROCIRCUIT,DI:HEX INV BUFFER,BURN-IN	27014	DM8016
U30420	156-0733-02			MICROCIRCUIT,DI:DUAL MONOSTABLE MV,SCRN	04713	SN74LS221N/J
U30500	156-0385-02			MICROCIRCUIT,DI:HEX INVERTER	01295	SN74LS04
U30600	156-0480-02			MICROCIRCUIT,DI:QUAD 2 INP & GATE	01295	SN74LS08NP3
U30610	156-0382-02			MICROCIRCUIT,DI:QUAD 2-INP NAND GATE	01295	SN74LS00
U30630	156-0981-00	B010100	B041353	MICROCIRCUIT,DI:2048 X 8 ROM,CUSTOM MASK	80009	156-0981-00
U30630	160-1511-00	B041607		MICROCIRCUIT,DI:2048 X 8 EPROM,PROGRAMMED	80009	160-1511-00
U30700	156-0464-02			MICROCIRCUIT,DI:DUAL 4 INP NAND GATE	01295	SN74LS20
U30710	156-0067-00			MICROCIRCUIT,LI:OPERATIONAL AMPLIFIER	01295	MICROA741CP
U30720	156-0467-02			MICROCIRCUIT,DI:QUAD 2-INP NAND BFR,SCRN	01295	SN74LS38
U30810	156-0927-00			MICROCIRCUIT,LI:DIGITAL TO ANALOG CONVERTER	80009	156-0927-00
U30830	156-0980-00	B010100	B041353	MICROCIRCUIT,DI:2048 X 8 ROM,CUSTOM MASK	80009	156-0980-00
U30830	160-1512-00	B041607		MICROCIRCUIT,DI:2048 X 8 EPROM,PROGRAMMED	80009	160-1512-00
U30900	156-0427-00	B010100	B040951	MICROCIRCUIT,DI:PERIPHERAL INTERFACE ADPTR	04713	MC6820(L OR P)
U40900	156-0427-04	B040952		MICROCIRCUIT,DI:PERIPHERAL INTERFACE ADPTR	80009	156-0427-04
U30920	156-0426-00	B010100	B030569	MICROCIRCUIT,DI:MICROPROCESSOR	04713	MC6800S
U30920	156-0426-05	B030570		MICROCIRCUIT,DI:MICROPROCESSOR,SCREENED	80009	156-0426-05
U31630	160-1511-00	B041354	B041606	MICROCIRCUIT,DI:2048 X 8 EPROM,PROGRAMMED	80009	160-1511-00
U31830	160-1512-00	B041354	B041606	MICROCIRCUIT,DI:2048 X 8 EPROM,PROGRAMMED	80009	160-1512-00
U60240	155-0078-10			MICROCIRCUIT,LI:ML,VERTICAL AMPLIFIER	80009	155-0078-10
U60340	155-0078-10			MICROCIRCUIT,LI:ML,VERTICAL AMPLIFIER	80009	155-0078-10
U60440	155-0078-10			MICROCIRCUIT,LI:ML,VERTICAL AMPLIFIER	80009	155-0078-10
U60540	155-0078-10			MICROCIRCUIT,LI:ML,VERTICAL AMPLIFIER	80009	155-0078-10
U60610	156-0479-02			MICROCIRCUIT,DI:QUAD 2-INP OR GATE	01295	SN74LS32NP3
U60710	156-0385-02			MICROCIRCUIT,DI:HEX INVERTER	01295	SN74LS04
U60810	156-0140-02			MICROCIRCUIT,DI:HEX BUFFERS W/OC HV OUT	27014	DM8017NA+/JA+
U60910	156-0093-02			MICROCIRCUIT,DI:HEX INV BUFFER,BURN-IN	27014	DM8016
U301000	156-0427-00	B010100	B040951	MICROCIRCUIT,DI:PERIPHERAL INTERFACE ADPTR	04713	MC6820(L OR P)
U301000	156-0427-04	B040952		MICROCIRCUIT,DI:PERIPHERAL INTERFACE ADPTR	80009	156-0427-04
U301030	156-0716-00			MICROCIRCUIT,DI:RAM,128 X 8 STATIC	04713	MCM6810S
U301200	156-0427-00	B010100	B040951	MICROCIRCUIT,DI:PERIPHERAL INTERFACE ADPTR	04713	MC6820(L OR P)
U301200	156-0427-04	B040952		MICROCIRCUIT,DI:PERIPHERAL INTERFACE ADPTR	80009	156-0427-04
U301220	156-0736-02			MICROCIRCUIT,DI:BCD TO DECIMAL DCDR	80009	156-0736-02
U301226	156-0382-02			MICROCIRCUIT,DI:QUAD 2-INP NAND GATE	01295	SN74LS00
U301230	156-0656-02			MICROCIRCUIT,DI:DECADE COUNTER,BURN-IN	01295	SN74LS90
U301310	155-0135-00			MICROCIRCUIT,DI:DUAL IN LINE,20 LEAD	80009	155-0135-00
U301320	156-0541-02			MICROCIRCUIT,DI:DUAL 2 TO 4 LINE DCDR	01295	SN74LS139NP3
U301330	156-0479-02			MICROCIRCUIT,DI:QUAD 2-INP OR GATE	01295	SN74LS32NP3
U301420	156-0386-02			MICROCIRCUIT,DI:TRIPLE 3-INP NAND GATE	27014	DM74LS10N
U301430	156-0405-03			MICROCIRCUIT,DI:DUAL RETRIG MONOSTABLE MV	07263	9602
U301500	155-0164-00			MICROCIRCUIT,DI:TIME SLOT SWITCH	80009	155-0164-00
U301520	156-0645-02			MICROCIRCUIT,DI:HEX INV ST NAND GATES,SCRN	01295	SN74LS14

Ckt No.	Tektronix Part No.	Serial/Model No.		Name & Description	Mfr Code	Mfr Part Number
		Eff	Dscont			
U301530	156-0382-02			MICROCIRCUIT,DI:QUAD 2-INP NAND GATE	01295	SN74LS00
U301620	156-0467-02			MICROCIRCUIT,DI:QUAD 2-INP NAND BFR,SCRN	01295	SN74LS38
U301630	156-0388-03			MICROCIRCUIT,DI:DUAL D FLIP-FLOP	07263	74LS74A
VR10303	153-0059-00			SEMICON DVC,SE:ZENER,0.4W,4.75V,5%,SEL	80009	153-0059-00
VR20310	152-0149-00			SEMICON DVC,SE:ZENER,0.4W,10V,5%	04713	SZG35009K3
VR30226	152-0437-00	B010100	B029999	SEMICON DVC,SE:ZENER,SI,8.2V,2%,0.4W	14552	TD332679
VR30226	152-0662-00	B030000		SEMICON DVC,SE:ZENER,0.4W,5V,1%	04713	SZG195
VR30530	152-0508-00	B010100	B041606	SEMICON DVC,SE:ZENER,0.4W,12.6V,5%	80009	152-0508-00
VR30534	152-0265-00			SEMICON DVC,SE:ZENER,0.4W,24V,5%	04713	SZG35009K8
VR301230	152-0055-00			SEMICON DVC,SE:ZENER,0.4W,11V,5%	04713	SZG35009K1
VR301236	152-0590-00			SEMICON DVC,SE:ZENER,18V,5% AT 7MA	04713	SZG35014K2
W30016	131-0566-00			BUS CONDUCTOR:DUMMY RES,2.375,22 AWG	57668	JWW-0200E0
W60010	131-0566-00			BUS CONDUCTOR:DUMMY RES,2.375,22 AWG	57668	JWW-0200E0
W301435	131-0566-00	B041607		BUS CONDUCTOR:DUMMY RES,2.375,22 AWG	57668	JWW-0200E0
W301712	131-0566-00	B010100	B041606	BUS CONDUCTOR:DUMMY RES,2.375,22 AWG	57668	JWW-0200E0
W30528	131-0566-00	B041607		BUS CONDUCTOR:DUMMY RES,2.375,22 AWG	57668	JWW-0200E0

DIAGRAMS AND CIRCUIT BOARD ILLUSTRATIONS

Symbols and Reference Designators

Electrical components shown on the diagrams are in the following units unless noted otherwise:

- Capacitors = Values one or greater are in picofarads (pF).
Values less than one are in microfarads (μF).
- Resistors = Ohms (Ω).

Graphic symbols and class designation letters are based on ANSI Standard Y32.2-1975.

Logic symbology is based on ANSI Y32.14-1973 in terms of positive logic. Logic symbols depict the logic function performed and may differ from the manufacturer's data.

The overline on a signal name indicates that the signal performs its intended function when it goes to the low state.

Abbreviations are based on ANSI Y1.1-1972.

Other ANSI standards that are used in the preparation of diagrams by Tektronix, Inc. are:

- Y14.15, 1966 Drafting Practices.
- Y14.2, 1973 Line Conventions and Lettering.
- Y10.5, 1968 Letter Symbols for Quantities Used in Electrical Science and Electrical Engineering.

The following prefix letters are used as reference designators to identify components or assemblies on the diagrams.

A	Assembly, separable or repairable (circuit board, etc)	H	Heat dissipating device (heat sink, heat radiator, etc)	S	Switch or contactor
AT	Attenuator, fixed or variable	HR	Heater	T	Transformer
B	Motor	HY	Hybrid circuit	TC	Thermocouple
BT	Battery	J	Connector, stationary portion	TP	Test point
C	Capacitor, fixed or variable	K	Relay	U	Assembly, inseparable or non-repairable (integrated circuit, etc.)
CB	Circuit breaker	L	Inductor, fixed or variable	V	Electron tube
CR	Diode, signal or rectifier	M	Meter	VR	Voltage regulator (zener diode, etc.)
DL	Delay line	P	Connector, movable portion	W	Wirestrap or cable
DS	Indicating device (lamp)	Q	Transistor or silicon-controlled rectifier	Y	Crystal
E	Spark Gap, Ferrite bead	R	Resistor, fixed or variable	Z	Phase shifter
F	Fuse	RT	Thermistor		
FL	Filter				

The following special symbols may appear on the diagrams:

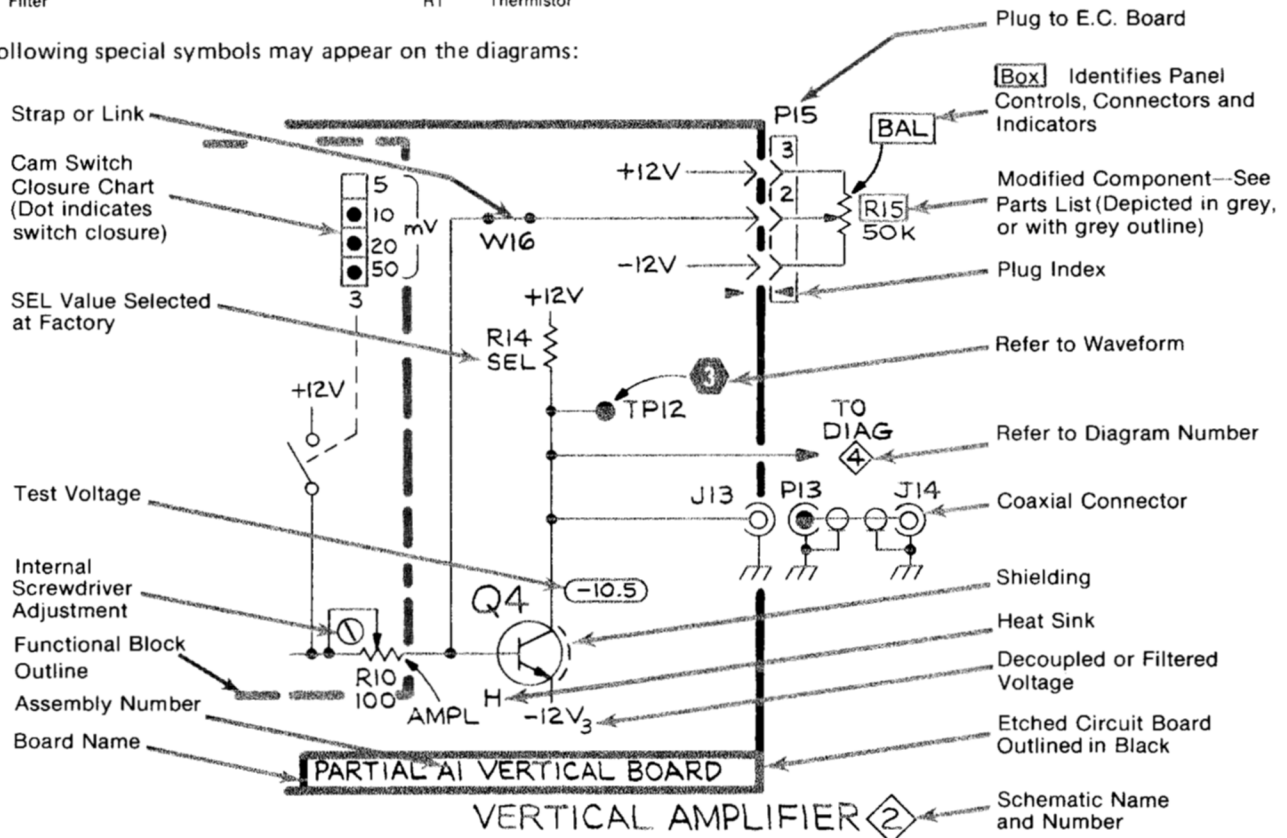

7A16P INSTRUCTION

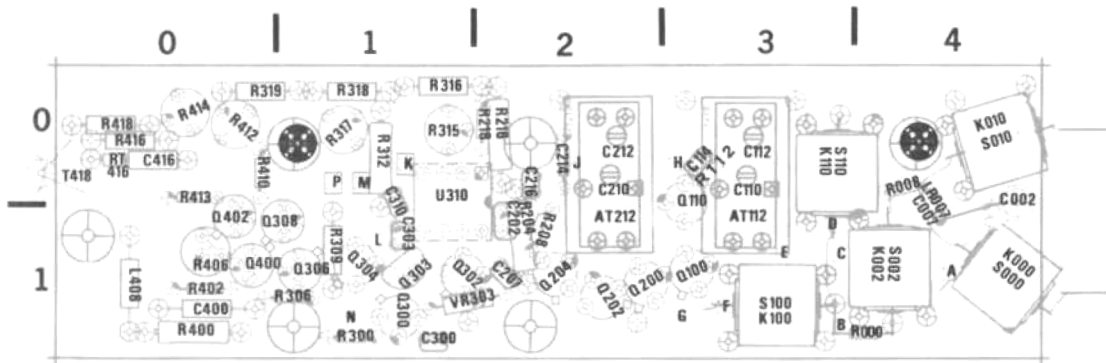

Fig. 8-1a. A10 Attenuator Board-Front

7A16P INSTRUCTION

0

1

2

3

4

0

1

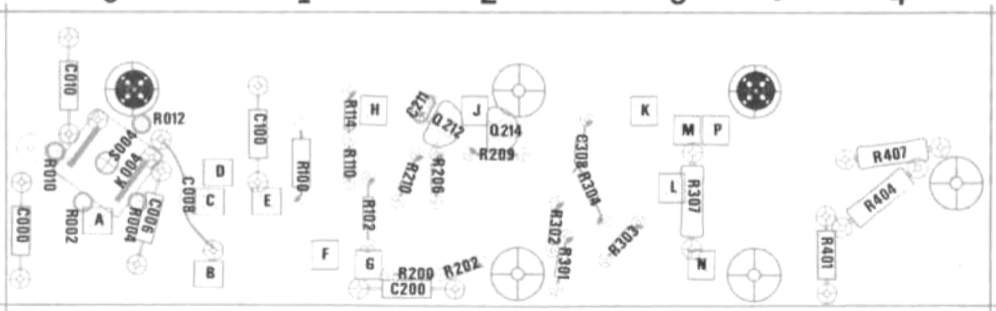

Fig. 8-1b. A10 Attenuator Board-Rear

7A16P INSTRUCTION

0 | 1 | 2 | 3

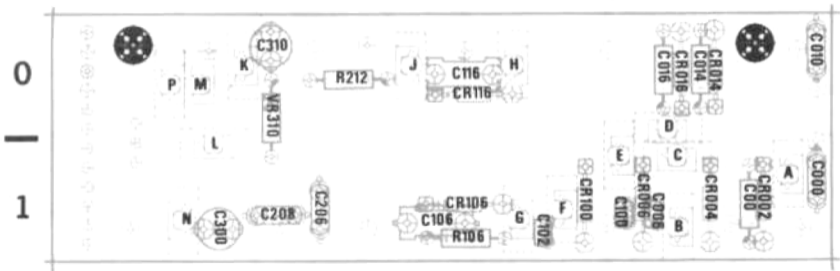

Fig. 8-2. A20 Actuator Board

A10 ATTENUATOR BOARD

COMPONENT NUMBER	SCHEMATIC LOCATION		BOARD LOCATION		COMPONENT NUMBER	SCHEMATIC LOCATION		BOARD LOCATION	
	COL	ROW	COL	ROW		COL	ROW	COL	ROW
AT112	E	2	3	1	Q212	C	3	2	0
AT212	E	3	3	1	Q214	C	4	2	0
C000	B	2	0	1	Q300	E	5	1	1
C002	C	2	4	0	Q302	E	4	2	1
C006	B	1	0	1	Q303	D	4	1	1
C007	C	2	4	1	Q304	F	4	1	1
C008	D	2	0	1	Q306	E	5	1	1
C010	B	2	0	0	Q308	E	6	1	1
C100	C	1	1	0	Q400	F	6	1	1
C110	E	2	3	0	Q402	F	6	0	1
C112	E	2	3	0	R000	D	2	4	1
C114	D	3	3	0	R002	D	2	0	1
C200	B	3	2	1	R004	D	2	0	1
C202	D	5	2	1	R008	C	2	4	0
C207	D	4	2	1	R010	D	2	0	1
C210	E	3	2	0	R012	D	2	0	0
C211	C	3	2	1	R100	E	2	1	1
C212	E	3	2	0	R102	D	3	1	1
C214	C	4	2	0	R110	C	3	1	1
C216	E	4	2	0	R112	E	4	3	0
C300	D	5	1	1	R114	C	3	1	0
C303	F	4	1	1	R200	C	4	2	1
C308	D	4	3	0	R202	C	4	2	1
C310	B	4	1	0	R204	D	4	2	1
C400	C	5	0	1	R206	E	3	2	1
C416	G	6	0	0	R208	C	4	2	1
K000	C	2	4	1	R209	E	4	2	0
K002	D	1	4	1	R210	C	3	2	1
K004	C	1	0	1	R216	C	5	2	0
K010	C	1	4	0	R218	C	5	2	0
K100	E	1	3	1	R300	E	5	1	1
K110	E	1	3	0	R301	E	4	2	1
L408	F	6	0	1	R302	D	4	2	1
LR007	C	2	4	0	R303	E	4	3	1
Q100	D	3	3	1	R304	D	4	3	1
Q110	D	3	3	0	R306	E	5	1	1
Q200	D	3	2	1	R307	D	5	3	1
Q202	D	4	2	1	R309	F	5	1	1
Q204	D	4	2	1	R312	D	5	1	0
					R315	C	5	1	0
					R316	C	5	1	0
					R317	C	5	1	0
					R318	C	5	1	0

COMPONENT NUMBER	SCHEMATIC LOCATION		BOARD LOCATION		COMPONENT NUMBER	SCHEMATIC LOCATION		BOARD LOCATION	
	COL	ROW	COL	ROW		COL	ROW	COL	ROW
R319	C	5	1	0	R418	G	6	0	0
R400	F	6	0	1	S000	C	2	4	1
R401	F	5	4	1	S002	D	2	4	1
R402	E	6	0	1	S004	C	2	0	0
R404	G	6	4	1	S010	C	2	4	0
R406	G	5	0	1	S100	E	2	3	1
R407	F	6	4	0	S110	E	2	3	0
R410	E	6	1	0	T418	H	6	0	0
R412	C	5	0	0	U310	D	5	2	0
R413	E	6	0	0	VR303	E	5	2	1
R414	G	6	0	0					
R416	G	6	0	0					

A20 ACTUATOR BOARD

COMPONENT NUMBER	SCHEMATIC LOCATION		BOARD LOCATION		COMPONENT NUMBER	SCHEMATIC LOCATION		BOARD LOCATION	
	COL	ROW	COL	ROW		COL	ROW	COL	ROW
C000	A	2	3	1	CR004	A	1	3	1
C006	B	1	3	1	CR006	A	1	3	1
C014	B	2	3	0	CR014	A	1	3	0
C016	B	1	3	0	CR016	A	1	3	0
C100	B	1	2	1	CR100	A	1	2	1
C102	B	1	2	1	CR106	A	3	2	1
C106	A	4	1	1	CR116	A	3	2	0
C116	A	3	2	0					
C206	A	2	1	1	E010	B	2	CHASSIS	
C208	A	2	1	1	E000	B	2	CHASSIS	
C300	B	4	0	1					
C310	A	4	1	0	R106	A	4	2	1
C1010	A	2	3	0	R212	A	3	1	0
CR002	A	1	3	1	VR310	B	4	1	0

A B C D E F G H

1

2

3

4

5

6

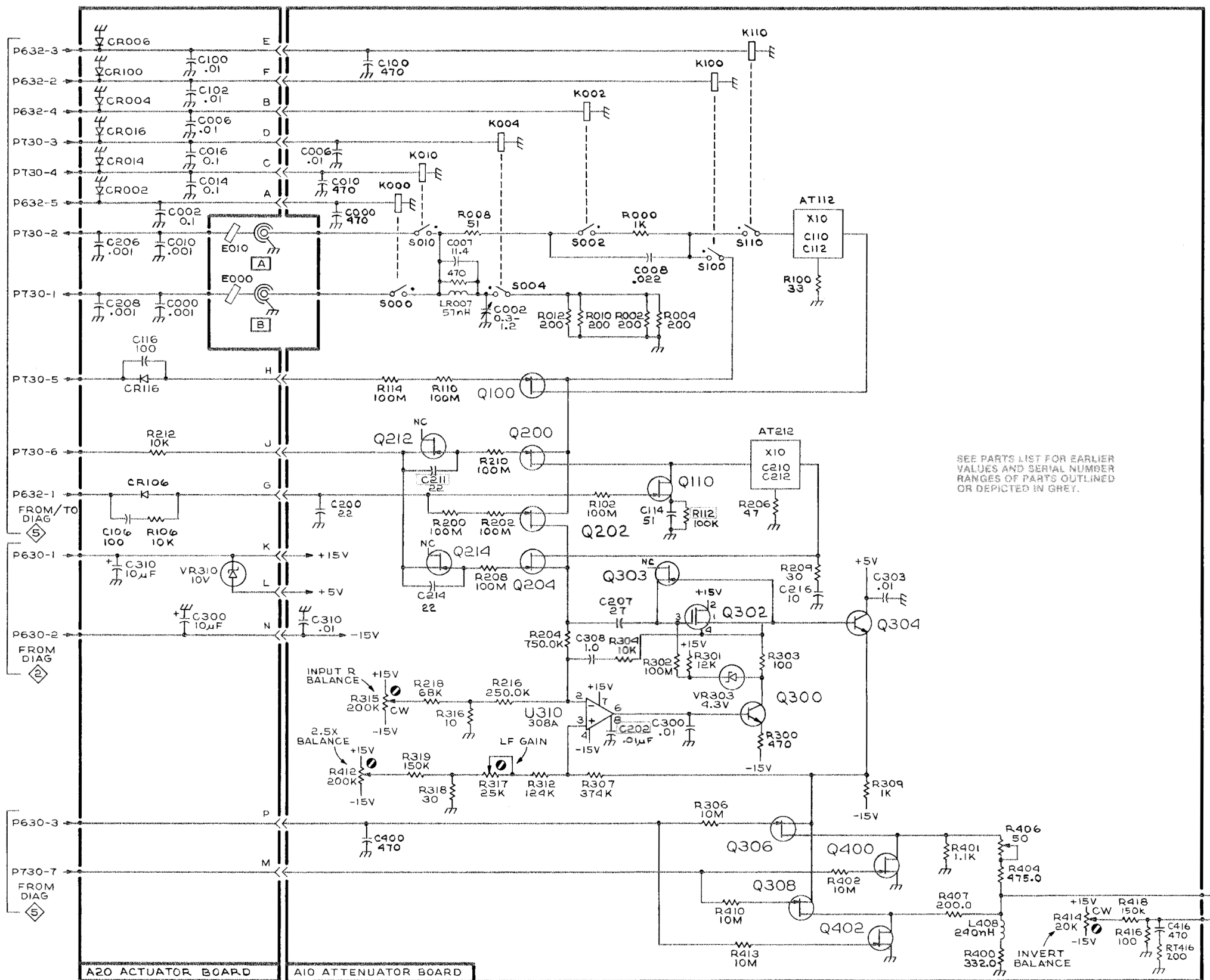

P/O A60 AMPLIFIER BOARD

P/O A30 PROGRAMMING LOGIC BOARD

COMPONENT NUMBER	SCHEMATIC LOCATION		BOARD LOCATION	
	COL	ROW	COL	ROW
J120	H	5	17	2
J125	H	6	17	2
J138	H	3	17	3
J140	H	5	17	3

COMPONENT NUMBER	SCHEMATIC LOCATION		BOARD LOCATION		COMPONENT NUMBER	SCHEMATIC LOCATION		BOARD LOCATION		COMPONENT NUMBER	SCHEMATIC LOCATION		BOARD LOCATION	
	COL	ROW	COL	ROW		COL	ROW	COL	ROW		COL	ROW	COL	ROW
C006	F	5	0	0	L050	F	4	0	5	R142	E	5	1	4
C010	F	6	0	1	L540	C	1	5	4	R143	D	4	1	4
C012	F	6	0	1	LR120	A	5	1	2	R148	E	4	1	4
C014	F	6	0	1	LR122	A	6	1	2	R150	E	5	1	5
C040	F	4	0	4	P630	H	1	6	3	R202	A	4	2	0
C042	F	4	0	4	Q100	E	5	1	0	R212	B	5	2	1
C044	F	4	0	4	Q110	E	5	1	0	R214	A	4	2	1
C046	F	5	0	4	Q112	E	6	1	1	R215	A	4	2	1
C120	A	5	1	2	Q114	E	6	1	1	R220	C	4	2	2
C122	A	6	1	2	Q114	E	6	1	1	R222	C	4	2	2
C128	C	4	1	2	Q132	E	4	1	3	R224	B	4	2	2
C143	D	4	1	4	Q140	E	3	1	4	R230	C	4	2	3
C212	A	5	2	1	Q142	E	5	1	4	R234	C	4	2	3
C220	B	5	2	2	Q144	E	4	1	4	R235	B	3	2	3
C224	B	6	2	2	Q214	B	4	2	1	R237	B	4	2	3
C226	B	5	2	2	Q320	B	4	3	2	R238	B	4	2	3
C232	C	4	2	3	R000	G	5	0	0	R240	C	5	2	4
C314	B	4	3	1	R004	F	5	0	0	R242	B	4	2	4
†C334	G	2	3	3	R006	F	5	0	0	R250	C	3	2	5
C336	G	2	3	3	R010	G	6	0	1	R252	C	3	2	5
C338	E	2	4	3	R014	F	6	0	1	R302	A	4	3	0
C350	C	2	3	5	R016	F	6	0	1	R304	A	4	3	0
C424	D	2	4	2	R020	G	6	0	2	R310	B	4	3	1
C430	D	2	4	3	R030	G	4	0	3	R312	B	4	3	1
C434	D	2	4	3	R032	F	4	0	3	R314	A	4	3	1
C452	E	1	4	5	R034	F	3	0	3	R315	A	3	3	1
C520	H	1	5	2	R040	G	4	0	4	R316	B	4	3	1
C522	B	2	5	2	R046	F	5	0	4	R318	F	3	3	1
C526	H	1	6	2	R048	F	4	0	4	R326	F	3	3	2
C532	C	1	5	3	R050	G	4	0	5	R330	G	2	3	3
C536	B	2	5	3	R100	E	5	1	0	R332	G	2	3	3
C538	A	2	5	3	R102	E	5	1	0	R333	F	3	3	2
C554	B	3	5	5	R104	E	5	1	0	R334	F	2	3	3
CR004	F	5	0	0	R110	D	5	1	1	R335	F	2	3	2
CR014	F	6	0	1	R112	E	6	1	1	R336	F	2	3	3
CR032	F	4	0	3	R114	E	6	1	1	R337	G	2	3	3
CR046	F	5	0	4	R116	E	6	1	1	R338	F	1	3	2
CR314	A	4	3	1	R120	E	6	1	2	R339	E	1	3	3
CR338	E	1	3	3	R130	E	3	1	3	R340	F	2	3	4
CR802	D	5	8	0	R132	E	4	1	3	R342	F	2	3	4
J020	G	6	0	2	R134	E	4	1	3	R350	G	3	3	5
J025	G	5	0	2	R136	E	4	1	4	R354	F	1	3	5
J038	G	5	0	3	R137	C	4	1	3	R355	F	1	3	5
J040	G	3	0	4	R138	C	4	1	3	R359	D	1	3	5
L002	F	5	0	0	R140	E	3	1	4	R410	A	4	4	1
L020	F	6	0	1						R418	D	2	4	1
L030	F	4	0	3						R422	D	2	4	2
										R424	D	2	4	2
										R430	D	2	4	3
										R432	D	2	4	3
										R434	D	2	4	3
										R435	D	2	4	3
										R436	D	2	4	3
										R437	E	2	4	3
										R438	D	2	4	3
										R440	E	2	3	4
										R442	E	1	3	4
										R443	E	3	4	4
										R446	C	2	4	4
										R448	C	2	4	4
										R449	C	2	4	4
										R452	E	1	4	5
										R454	D	1	4	5
										R456	D	1	4	5
										R458	D	1	4	5
										R520	H	1	5	2
										R522	B	2	5	2
										R524	B	2	5	2
										R526	H	1	6	2
										R528	A	2	6	3
										R530	B	3	5	3
										R532	B	3	5	3
										R533	B	2	5	3
										R534	B	2	5	3
										R535	B	2	5	3
										R536	B	1	5	3
										R540	C	1	5	4
										R550	C	2	5	5
										R552	B	1	5	4
										R554	B	1	5	4
										R556	B	1	5	5
										R558	A	1	5	5
										R701	D	6	7	0
										R702	D	6	7	0
										R800	D	5	8	0
										R802	D	5	8	0
										RT526	A	2	5	3
										RT238	F	2	2	3
										U240	D	3	2	4
										U340	H	1	3	4
										U440	E	3	4	4
										U540	B	3	5	4
										U710E	C	6	7	1
										U810E	D	6	8	1
										U910E	D	6	9	1
										W010	G	5	0	1

†Back of board.

MICROPROCESSOR

3

P/O A30 PROGRAM LOGIC BOARD (SN B041607 & up).

COMPONENT NUMBER	SCHEMATIC LOCATION		BOARD LOCATION		COMPONENT NUMBER	SCHEMATIC LOCATION		BOARD LOCATION		COMPONENT NUMBER	SCHEMATIC LOCATION		BOARD LOCATION	
	COL	ROW	COL	ROW		COL	ROW	COL	ROW		COL	ROW	COL	ROW
C800	C	6	8	0	TP1020	B	3	10	1	U1030	D	2	10	3
P1420	E	3	14	2	TP1130	E	4	11	2	U1200	F	6	12	1
P1520	C	3	15	2	TP1300	F	4	13	0	U1320A	C	3	13	2
R115	H	6	1	1	TP1518	G	6	15	2	U1320B	E	3	13	2
R800	D	6	8	0	TP1538	G	6	15	3	U1330D	A	1	13	3
R810	A	3	8	1	U020A	G	6	0	2	U1520A	B	3	15	2
R1420	E	3	14	2	U600B	D	3	6	0	U1520B	D	3	15	2
R1520	C	3	14	2	U630	F	2	6	3	U1530A	D	3	15	3
TP620	G	6	5	1	U700B	C	6	7	0	W016	H	6	0	1
TP626	A	2	6	2	U830	G	2	8	3	W528	D	2	6	3
TP726	A	4	7	2	U900	B	6	9	1	W1435	H	2	14	3
					U920	A	1	9	2					
					U1000	E	6	10	0					

MICROPROCESSOR

3

P/O A30 PROGRAM LOGIC BOARD (SN B041606 & below).

COMPONENT NUMBER	SCHEMATIC LOCATION		BOARD LOCATION		COMPONENT NUMBER	SCHEMATIC LOCATION		BOARD LOCATION		COMPONENT NUMBER	SCHEMATIC LOCATION		BOARD LOCATION	
	COL	ROW	COL	ROW		COL	ROW	COL	ROW		COL	ROW	COL	ROW
C730	F	1	7	3	TP328	F	1	3	2	U900	B	6	9	0
C800	C	6	8	0	TP620	G	6	5	1	U920	A	1	9	2
E528	E	1	5	3	TP626	A	2	6	2	U1000	E	6	10	0
P1420	E	3	14	2	TP726	A	4	7	2	U1030	D	2	10	3
P1520	C	3	15	2	TP730	G	4	7	2	U1200	F	6	12	0
Q528	E	1	5	2	TP1020	B	3	10	2	U1320A	C	3	13	2
R115	H	6	1	1	TP1130	E	4	12	0	U1320B	E	3	13	2
R530	E	1	5	3	TP1300	F	4	13	0	U1330D	A	1	13	3
R800	D	6	8	0	TP1518	G	6	15	2	U1520A	B	3	15	2
R810	A	3	8	1	TP1538	G	6	15	3	U1520B	D	3	15	2
R1420	E	3	14	2	U020A	G	6	0	2	U1530A	D	3	15	3
R1520	C	3	15	2	U630	F	2	6	3	VR530	E	1	5	3
					U700B	C	6	7	0	W016	H	6	0	1
					U830	G	2	8	3					

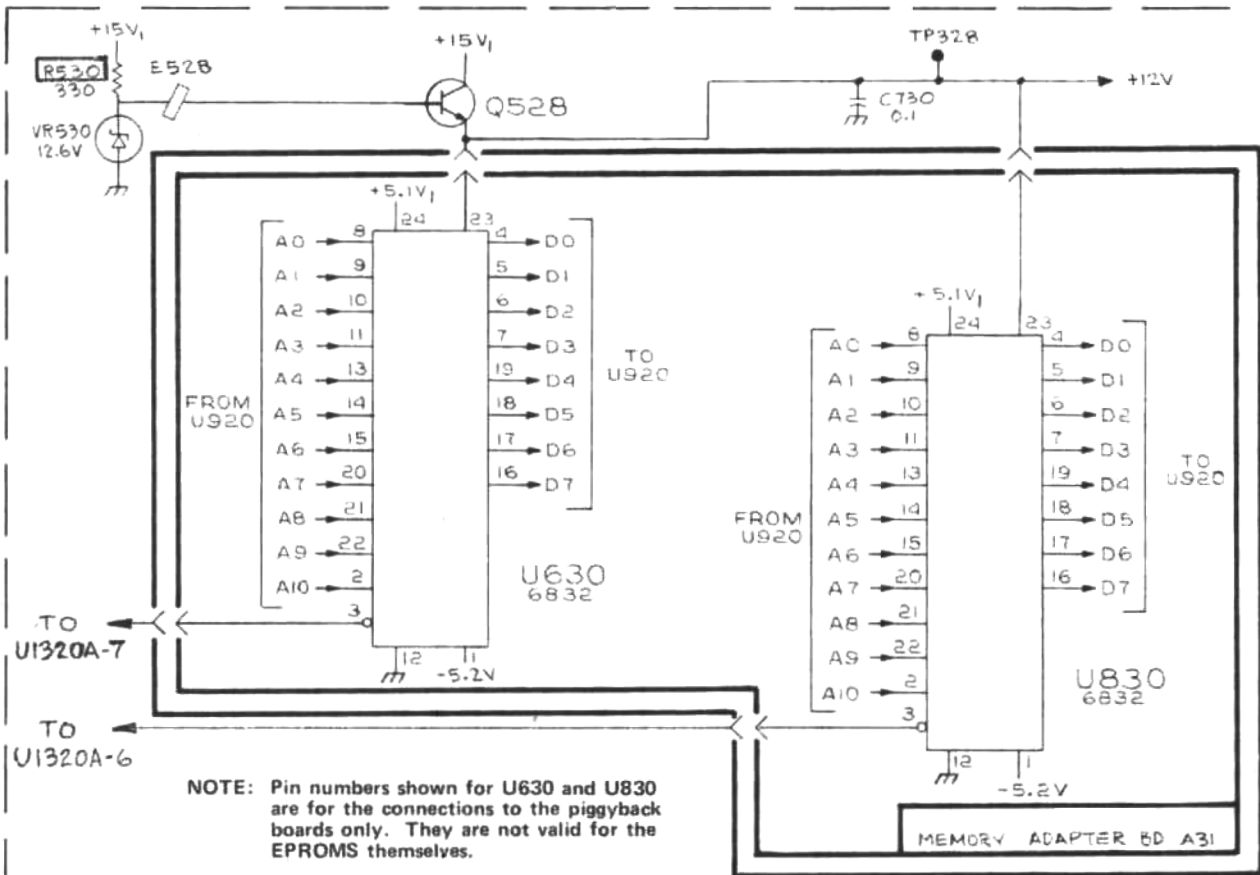

EFF: SN B041354 - B041607

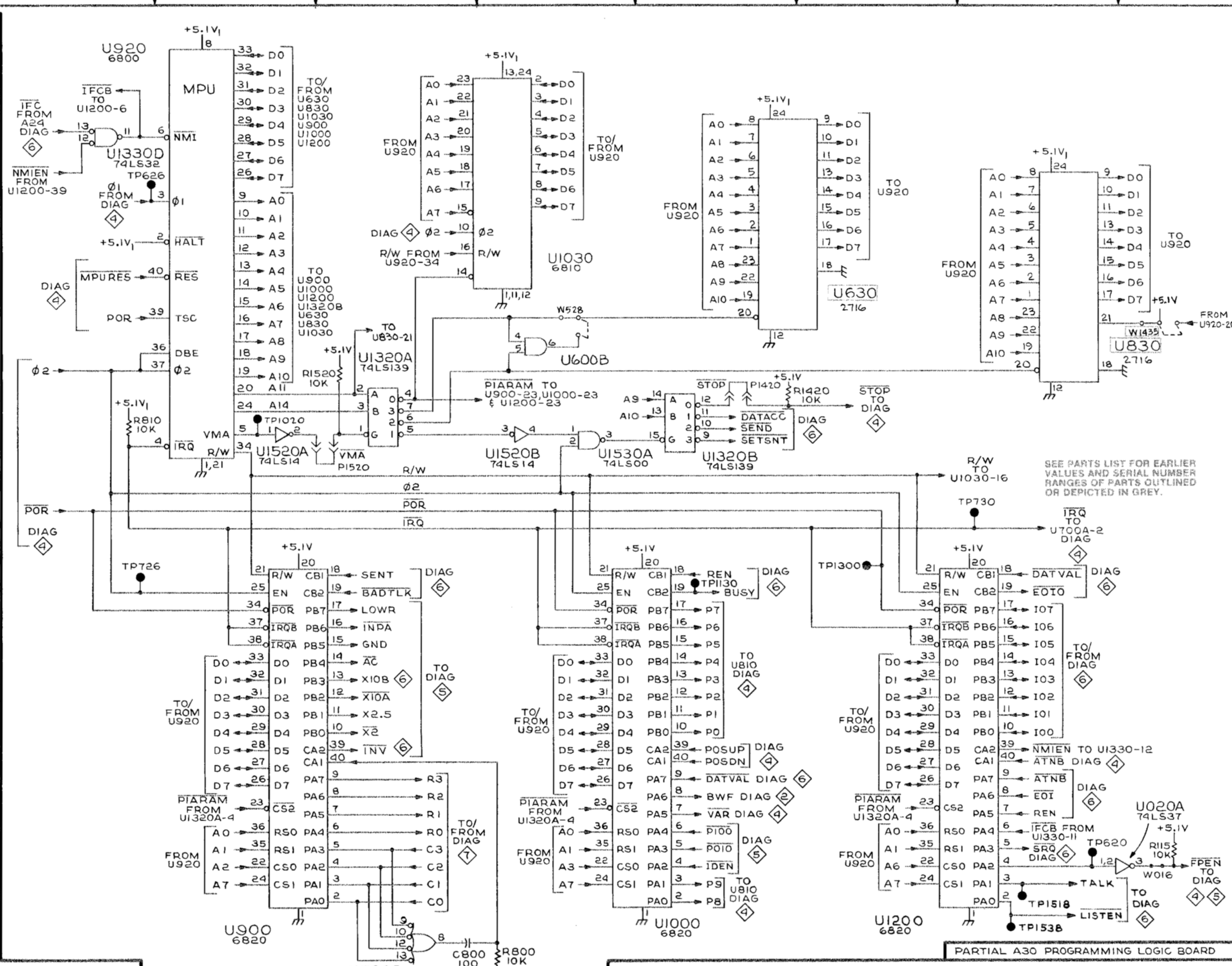

SEE PARTS LIST FOR EARLIER VALUES AND SERIAL NUMBER RANGES OF PARTS OUTLINED OR DEPICTED IN GREY.



Fig. 8-5. A30 Programming Logic Board

P/O A30 PROGRAMMING LOGIC BOARD

COMPONENT NUMBER	SCHEMATIC LOCATION		BOARD LOCATION		COMPONENT NUMBER	SCHEMATIC LOCATION		BOARD LOCATION	
	COL	ROW	COL	ROW		COL	ROW	COL	ROW
C116	C	2	1	1	R406	F	5	4	0
*C211	C	3	2	1	R420	C	4	4	2
C316	F	2	3	1	R422	C	4	4	2
C422	G	1	4	2	R504	D	4	5	0
C520	C	4	5	2	R514	G	1	5	1
C614	G	1	6	1	R520	G	1	5	2
C626	G	3	6	2	R522	H	1	5	2
C720	B	1	7	2	R524	D	4	5	2
C810	A	1	8	0	R526	G	3	5	2
C1332	F	3	13	3	R620	G	1	6	2
CR210	C	3	2	1	R622	G	1	6	2
CR212	C	3	2	1	R623	H	3	6	2
*CR324	B	6	3	2	R624	H	2	6	2
					R625	G	3	6	2
DS520	C	4	5	2	R626	G	2	6	2
					R628	B	1	6	2
Q308	E	5	3	0	R710	C	2	7	1
Q408	E	6	4	0	R812	B	1	8	1
Q520	D	4	5	2	R1330	F	3	13	3
Q620	H	1	6	2					
Q624	G	2	6	2	S004	D	6	0	0
					U120D	D	2	1	2
R010	G	5	0	1	U220A	D	2	2	1
*R020	A	3	0	2	U220B	B	5	2	1
R108	D	6	1	0	U220C	B	6	2	1
R122	C	3	1	1	U220D	B	4	2	1
R125	C	2	1	1	U410A	E	5	4	1
R126	C	1	1	2	U410B	E	6	4	1
R200	F	5	2	0	U420	F	3	4	1
R210	B	3	2	1	U420B	F	1	4	1
R212	C	2	2	1	U500D	H	3	5	0
R214	D	2	2	1	U500F	D	6	5	0
R220	D	2	2	2	U600A	D	6	6	0
*R224	B	5	2	2	U600C	G	4	6	0
*R226	B	5	2	2	U600D	E	4	6	0
R228	B	4	2	2	U610B	E	2	5	1
*R300	H	6	3	0	U610C	E	2	5	1
R306	E	5	3	0	U610D	E	3	5	1
R310	E	6	3	1	U700A	E	4	7	0
R312	E	5	3	1	U710	B	2	7	1
R314	E	6	3	1	U720A	D	4	7	2
R316	B	4	3	1	U720B	G	3	7	2
R320	B	4	3	2	U720D	G	2	7	2
R322	F	2	3	2	U810	B	2	8	1
*R324	B	6	3	2	U1330B	G	3	13	3
*R326	B	6	3	2	U1430A	F	4	14	3
R328	F	2	3	2	VR226	B	4	2	2

*P/O A40 LED BOARD

P/O A60 AMPLIFIER BOARD

COMPONENT NUMBER	SCHEMATIC LOCATION		BOARD LOCATION		COMPONENT NUMBER	SCHEMATIC LOCATION		BOARD LOCATION		COMPONENT NUMBER	SCHEMATIC LOCATION		BOARD LOCATION	
	COL	ROW	COL	ROW		COL	ROW	COL	ROW		COL	ROW	COL	ROW
P632	C	1	6	3	R620	F	2	6	1	R904	G	1	9	0
P632	C	3	6	3	R622	F	4	6	2	R920	B	4	9	2
P632	H	2	6	3	R700	G	1	7	0	R922	C	4	9	2
P632	H	4	6	3	R704	B	6	7	0	R924	B	4	9	2
P730	C	1	7	3	R706	B	6	7	0	R925	B	4	9	2
P730	C	3	7	3	R716	F	4	7	1	R926	C	4	9	2
P730	E	5	7	3	R720	F	4	7	2	R928	B	4	9	2
P730	H	1	7	3	R722	B	3	7	2					
					R724A	B	3	7	2	U610A	F	4	6	1
Q620	B	3	6	2	R724B	F	2	7	2	U610B	F	4	6	1
Q622	G	2	6	2	R724C	F	4	7	2	U610C	F	3	6	1
Q702	C	6	7	0	R724D	G	3	7	2	U710A	F	3	7	1
Q720	G	4	7	2	R724E	G	4	7	2	U710C	A	3	7	1
Q721	G	4	7	2	R274F	B	3	7	2	U710F	F	1	7	1
Q722	G	4	7	2	R729	B	1	8	2	U810A	A	4	8	1
Q724	B	3	7	2	R820	C	1	8	2	U810B	A	1	8	1
Q820	B	1	8	2	R821	B	1	8	2	U810C	A	4	8	1
Q822	C	4	8	2	R822	B	3	8	2	U810D	A	6	8	1
Q824	C	1	8	2	R823	C	4	8	2	U810F	G	1	8	1
Q900	B	6	9	0	R824	B	3	8	2	U910A	A	3	9	1
Q920	C	4	9	2	R825	B	1	8	2	U910B	A	1	9	1
Q922	C	4	9	2	R826	C	1	8	2	U910C	A	4	9	1
					R827	B	1	8	2	U910D	G	1	9	1
R416	G	1	4	1	R900	B	6	9	0	U910F	A	6	9	1
R616	B	3	6	1	R902	B	6	9	0					

P/O PROGRAMMING LOGIC BOARD—Refer to Fig. 8-4.

CR300	F	5	3	0	R101	C	2	1	1	U120B	G	5	1	2
CR302	F	5	3	0	R112	B	2	1	1	U120C	G	5	1	2
CR304	F	5	3	0	R114	B	3	1	1	U210A	A	5	2	1
CR400	F	5	4	0	R124	F	6	1	2	U210B	F	3	2	1
					R128	F	5	1	2	U210C	B	5	2	1
Q010	C	2	0	1	R300	F	5	3	0	U210D	E	5	2	1
Q016	C	3	0	1	R304	F	5	3	0	U410C	F	2	4	1
Q110	B	2	1	1	R404	G	5	4	0	U410D	G	6	4	1
Q300	F	5	3	0	R534	A	4	5	3	U410F	G	6	4	1
Q400	F	5	4	0						U500A	A	2	5	0
					U020B	G	3	0	2	U500B	A	2	5	0
R012	B	2	0	1	U020C	A	5	0	2	U610A	B	2	5	1
R020	F	5	0	1	U020D	F	3	0	2					
R022	F	5	0	2	U120A	G	6	1	2	VR534	A	3	5	3

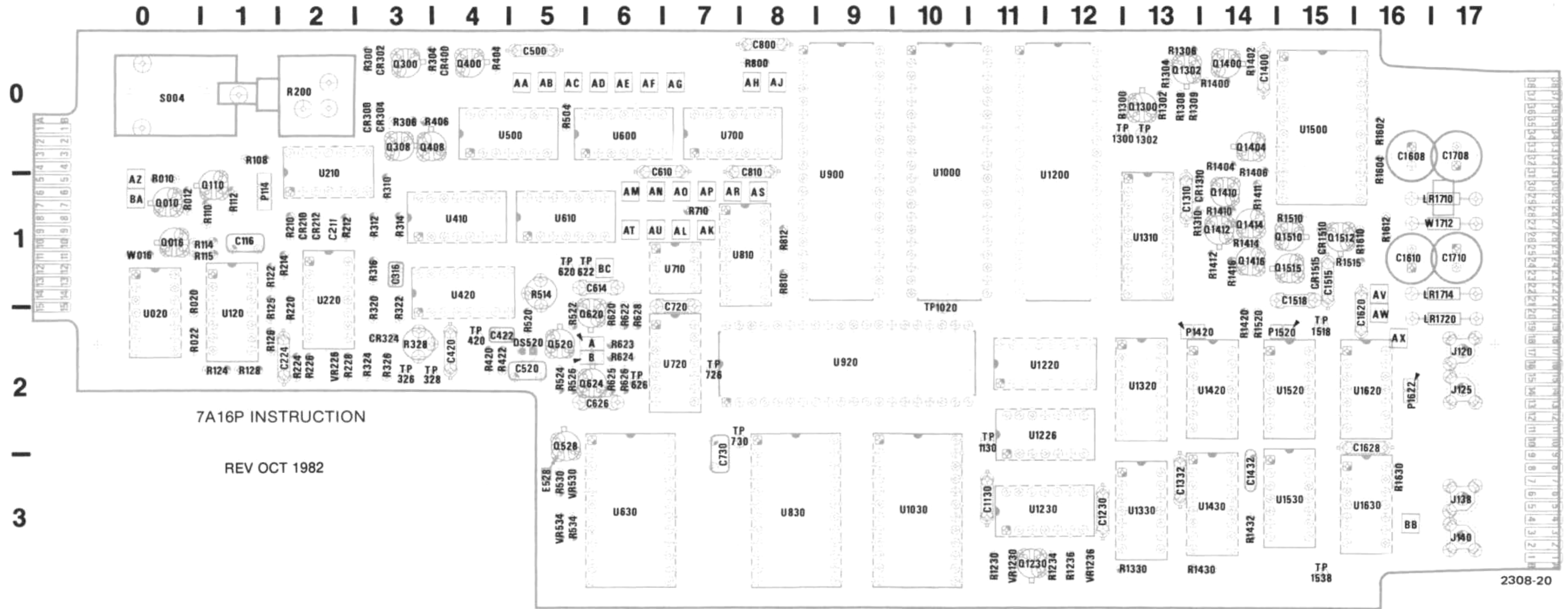
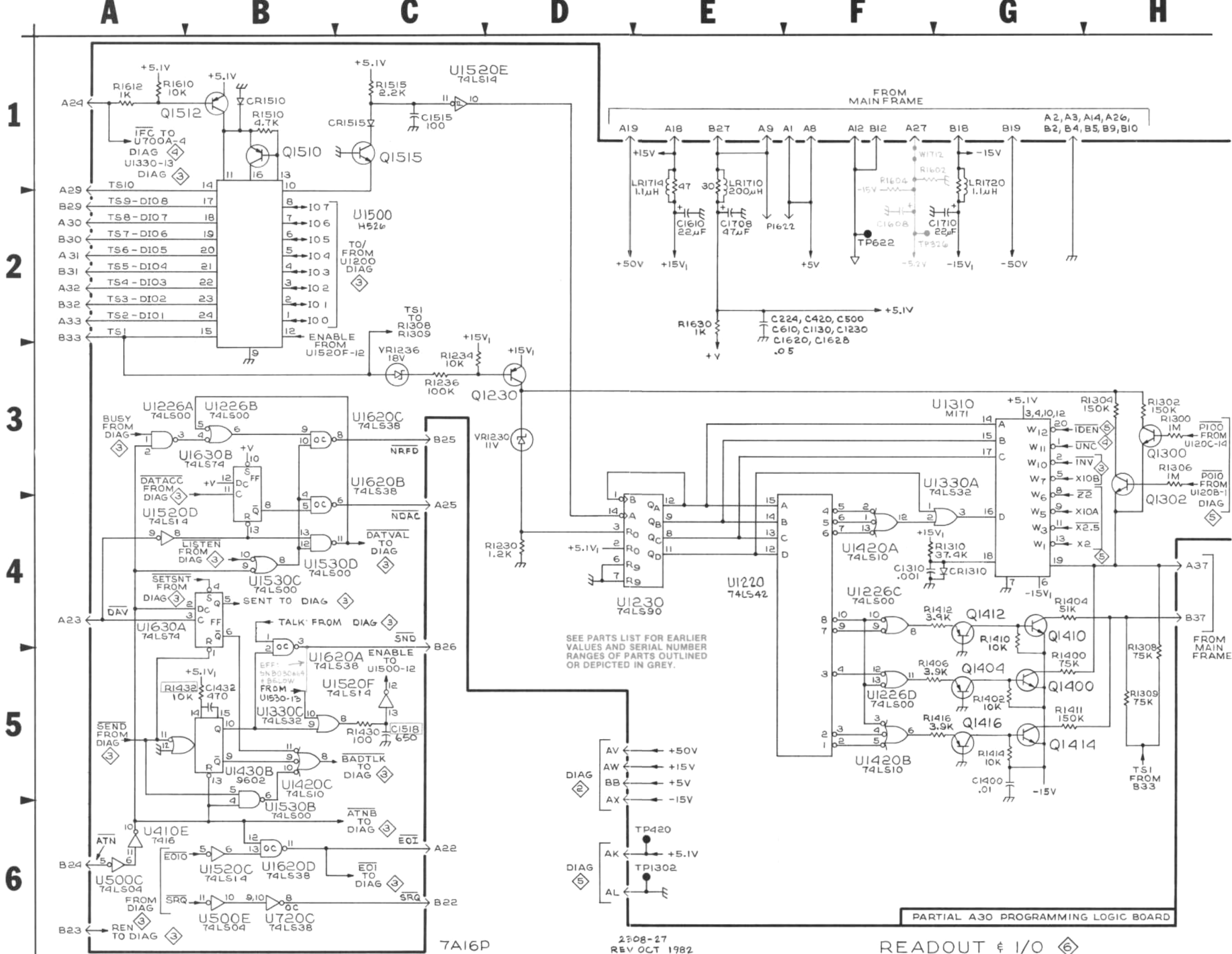

Fig. 8-7. A30 Programming Logic Board.

P/O A30 PROGRAMMING LOGIC BOARD

COMPONENT NUMBER	SCHEMATIC LOCATION		BOARD LOCATION		COMPONENT NUMBER	SCHEMATIC LOCATION		BOARD LOCATION		COMPONENT NUMBER	SCHEMATIC LOCATION		BOARD LOCATION	
	COL	ROW	COL	ROW		COL	ROW	COL	ROW		COL	ROW	COL	ROW
C224	E	2	2	2	Q1512	B	1	15	1	U410E	A	6	4	1
C420	E	2	4	2	Q1515	C	1	15	1	U500C	A	6	5	0
C500	E	2	5	0						U500E	B	6	5	0
C610	E	2	6	1	R1230	D	4	11	3	U720C	B	6	7	2
C1130	E	2	11	3	R1234	C	3	12	3	U1220	F	4	12	2
C1230	E	2	12	3	R1236	C	3	12	3	U1226A	A	3	12	2
C1310	F	4	13	1	R1300	H	3	12	0	U1226B	B	3	12	2
C1400	G	5	14	0	R1302	H	3	13	0	U1226C	F	4	12	2
C1432	B	5	14	3	R1304	H	3	13	0	U1226D	F	5	12	2
C1515	C	1	15	1	R1306	H	3	13	0	U1230	E	4	12	3
C1518	C	5	15	1	R1308	H	5	13	0	U1310	G	3	13	1
*C1608	F	2	16	0	R1309	H	5	13	0	U1330A	G	4	13	3
C1610	E	2	16	1	R1310	F	4	13	1	U1330C	B	5	13	3
C1620	E	2	16	2	R1400	G	5	14	0	U1420	F	4	14	2
C1628	E	2	16	2	R1402	G	5	14	0	U1420B	F	5	14	2
C1708	E	2	17	0	R1404	G	4	14	0	U1420C	B	5	14	2
C1710	G	2	17	1	R1406	F	5	14	0	U1430B	B	5	14	3
					R1410	G	4	14	1	U1500	B	2	15	0
CR1310	G	4	13	1	R1411	G	5	14	1	U1520C	B	6	15	2
CR1510	B	1	15	1	R1412	F	4	14	1	U1520D	A	4	15	2
CR1515	C	1	15	1	R1414	G	5	14	1	U1520E	C	1	15	2
					R1416	F	5	14	1	U1520F	C	5	15	2
LR1710	E	1	17	1	R1430	C	5	14	3	U1530B	B	6	15	3
LR1714	E	1	17	1	R1432	B	5	14	3	U1530C	B	4	15	3
LR1720	G	1	17	2	R1510	B	1	15	1	U1530D	B	4	15	3
					R1515	C	1	15	1	U1620A	B	5	16	2
Q1230	D	3	12	3	*R1602	F	1	16	0	U1620B	B	4	16	2
Q1300	H	3	13	0	*R1604	F	1	16	0	U1620C	C	3	16	2
Q1302	H	3	13	0	R1610	A	1	16	1	U1620D	B	6	16	2
Q1400	G	5	14	0	R1612	A	1	16	1	U1630A	B	4	16	3
Q1404	G	5	14	0	R1630	E	2	16	3	U1630B	B	3	16	3
Q1410	G	4	14	1										
Q1412	G	4	14	1	*TP326	F	2	3	2	VR1230	D	3	12	3
Q1414	G	5	14	1	TP420	E	6	4	2	VR1236	C	3	12	3
Q1416	G	5	14	1	TP622	F	2	6	1					
Q1510	B	1	15	1	TP1302	E	6	13	0	*W1712	F	1	17	1



SEE PARTS LIST FOR EARLIER VALUES AND SERIAL NUMBER RANGES OF PARTS OUTLINED OR DEPICTED IN GREY.

PARTIAL A30 PROGRAMMING LOGIC BOARD

2708-27
REV OCT 1982

READOUT & I/O

7A16P

7A16P INSTRUCTION

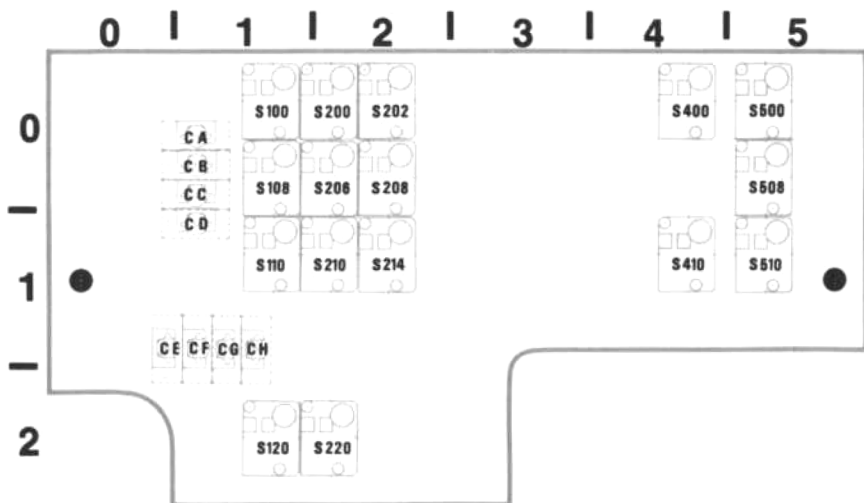

Fig. 8-8. A50 Switch Board.

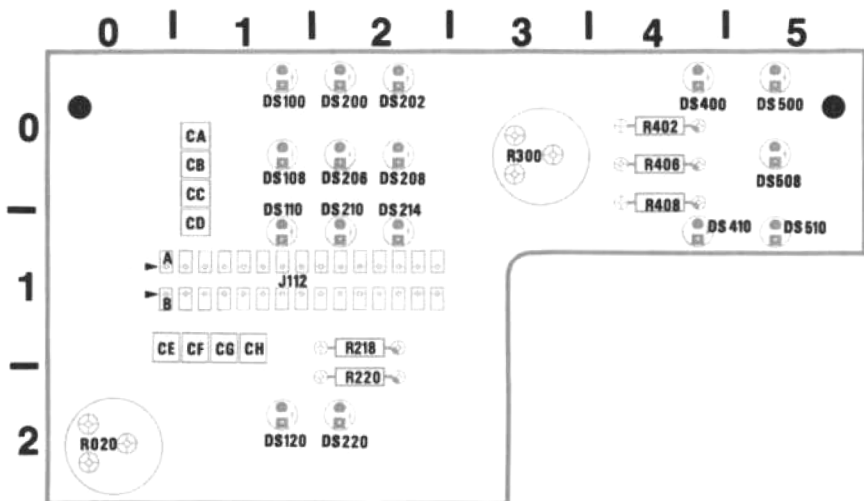

Fig. 8-9. A40 LED Board.

FRONT PANEL



P/O A50 SWITCH BOARD

COMPONENT NUMBER	SCHEMATIC LOCATION		BOARD LOCATION		COMPONENT NUMBER	SCHEMATIC LOCATION		BOARD LOCATION	
	COL	ROW	COL	ROW		COL	ROW	COL	ROW
S100	B	3	1	0	S210	C	3	2	1
S108	D	4	1	0	S214	B	2	2	1
S110	D	4	1	1	S220	C	4	2	2
S120	B	4	1	2	S400	B	1	4	0
S200	D	3	2	0	S410	D	2	4	1
S202	D	2	2	0	S500	D	1	5	0
S206	D	3	2	0	S508	D	1	5	0
S208	C	2	2	0	S510	C	1	5	1

P/O A40 LED Board

COMPONENT NUMBER	SCHEMATIC LOCATION		BOARD LOCATION		COMPONENT NUMBER	SCHEMATIC LOCATION		BOARD LOCATION	
	COL	ROW	COL	ROW		COL	ROW	COL	ROW
DS100	F	1	1	0	DS400	F	5	4	0
DS108	F	1	1	0	DS410	F	5	4	1
DS110	G	1	1	1	DS500	G	3	5	0
DS120	G	4	1	2	DS508	F	3	5	0
DS200	G	1	2	0	DS510	F	3	5	1
DS202	G	2	2	0					
DS206	F	1	2	0	R218	G	4	2	1
DS208	F	2	2	0	R220	F	4	2	2
DS210	F	1	2	1	R402	F	5	4	0
DS214	F	2	2	1	R406	F	3	4	0
DS220	G	4	2	2	R408	F	5	4	0

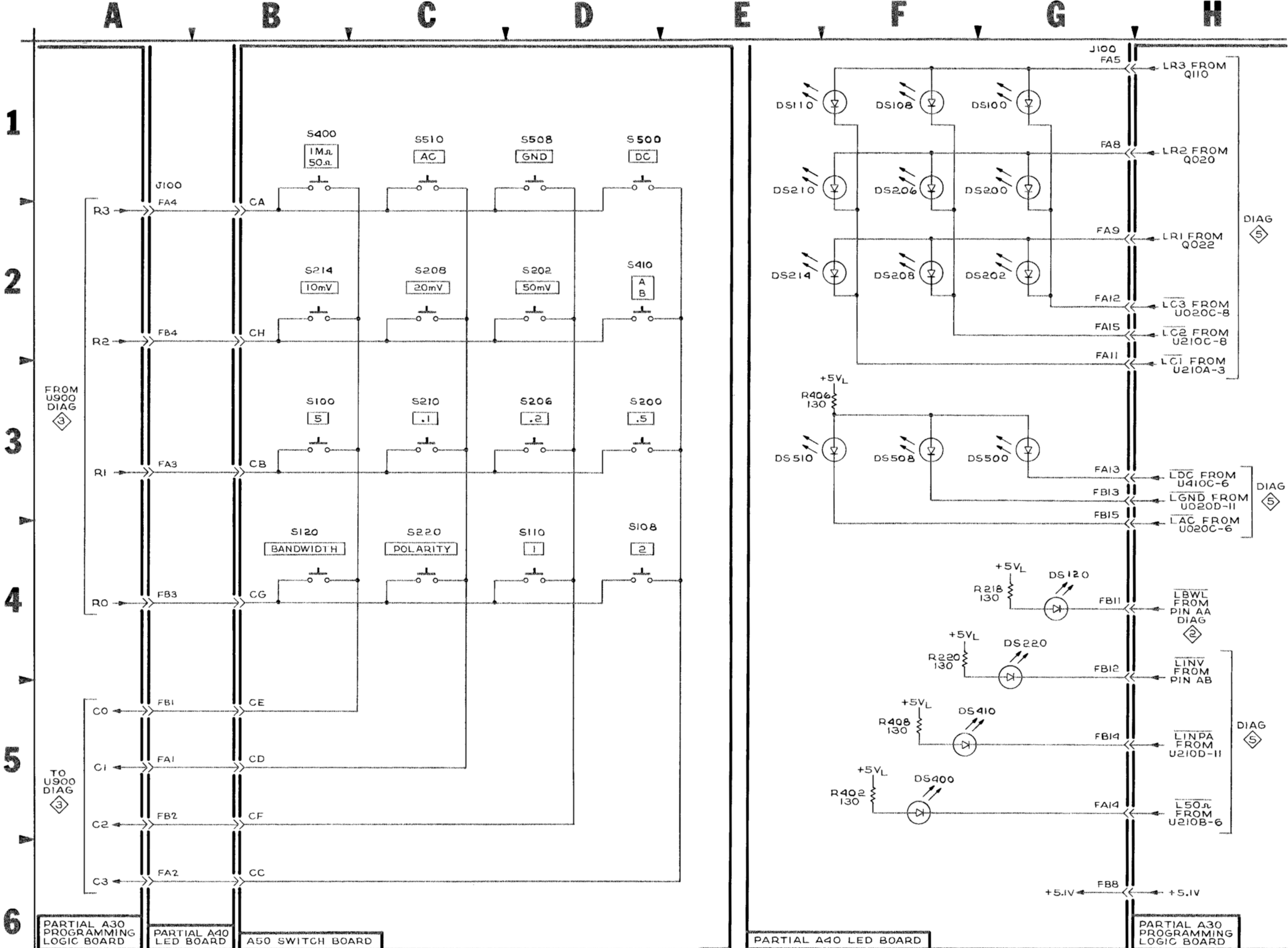

REPLACEABLE MECHANICAL PARTS

PARTS ORDERING INFORMATION

Replacement parts are available from or through your local Tektronix, Inc. Field Office or representative.

Changes to Tektronix instruments are sometimes made to accommodate improved components as they become available, and to give you the benefit of the latest circuit improvements developed in our engineering department. It is therefore important, when ordering parts, to include the following information in your order: Part number, instrument type or number, serial number, and modification number if applicable.

If a part you have ordered has been replaced with a new or improved part, your local Tektronix, Inc. Field Office or representative will contact you concerning any change in part number.

Change information, if any, is located at the rear of this manual.

SPECIAL NOTES AND SYMBOLS

X000 Part first added at this serial number
00X Part removed after this serial number

FIGURE AND INDEX NUMBERS

Items in this section are referenced by figure and index numbers to the illustrations.

INDENTATION SYSTEM

This mechanical parts list is indented to indicate item relationships. Following is an example of the indentation system used in the description column.

```

1 2 3 4 5           Name & Description
Assembly and/or Component
Attaching parts for Assembly and/or Component
    --- * ---
Detail Part of Assembly and/or Component
Attaching parts for Detail Part
    --- * ---
Parts of Detail Part
Attaching parts for Parts of Detail Part
    --- * ---
  
```

Attaching Parts always appear in the same indentation as the item it mounts, while the detail parts are indented to the right. Indented items are part of, and included with, the next higher indentation. The separation symbol --- * --- indicates the end of attaching parts.

Attaching parts must be purchased separately, unless otherwise specified.

ITEM NAME

In the Parts List, an Item Name is separated from the description by a colon (:). Because of space limitations, an Item Name may sometimes appear as incomplete. For further Item Name identification, the U.S. Federal Cataloging Handbook H6-1 can be utilized where possible.

ABBREVIATIONS

#	INCH NUMBER SIZE	ELECTRN	ELECTRON	IN	INCH	SE	SINGLE END
ACTR	ACTUATOR	ELEC	ELECTRICAL	INCAND	INCANDESCENT	SECT	SECTION
ADPTR	ADAPTER	ELECTLT	ELECTROLYTIC	INSUL	INSULATOR	SEMICOND	SEMICONDUCTOR
ALIGN	ALIGNMENT	ELEM	ELEMENT	INTL	INTERNAL	SHLD	SHIELD
AL	ALUMINIUM	EPL	ELECTRICAL PARTS LIST	LPHLDR	LAMPHOLDER	SHLDR	SHOULDERED
ASSEM	ASSEMBLED	EQPT	EQUIPMENT	MACH	MACHINE	SKT	SOCKET
ASSY	ASSEMBLY	EXT	EXTERNAL	MECH	MECHANICAL	SL	SLIDE
ATTEN	ATTENUATOR	FIL	FILLISTER HEAD	MTG	MOUNTING	SLFLKG	SELF-LOCKING
AWG	AMERICAN WIRE GAGE	FLEX	FLEXIBLE	NIP	NIPPLE	SLVG	SLEEVING
BD	BOARD	FLH	FLAT HEAD	NON WIRE	NOT WIRE WOUND	SPR	SPRING
BRKT	BRACKET	FLTR	FILTER	OBD	ORDER BY DESCRIPTION	SQ	SQUARE
BRS	BRASS	FR	FRAME or FRONT	OD	OUTSIDE DIAMETER	SST	STAINLESS STEEL
BRZ	BRONZE	FSTNR	FASTENER	OVH	OVAL HEAD	STL	STEEL
BSHG	BUSHING	FT	FOOT	PH BRZ	PHOSPHOR BRONZE	SW	SWITCH
CAB	CABINET	FXD	FIXED	PL	PLAIN or PLATE	T	TUBE
CAP	CAPACITOR	GSKT	GASKET	PLSTC	PLASTIC	TERM	TERMINAL
CER	CERAMIC	HDL	HANDLE	PN	PART NUMBER	THD	THREAD
CHAS	CHASSIS	HEX	HEXAGON	PNH	PAN HEAD	THK	THICK
CKT	CIRCUIT	HEX HD	HEXAGONAL HEAD	PWR	POWER	TNSN	TENSION
COMP	COMPOSITION	HEX SOC	HEXAGONAL SOCKET	RCPT	RECEPTACLE	TPG	TAPPING
CONN	CONNECTOR	HLCPS	HELICAL COMPRESSION	RES	RESISTOR	TRH	TRUSS HEAD
COV	COVER	HLEXT	HELICAL EXTENSION	RGD	RIGID	V	VOLTAGE
CPLG	COUPLING	HV	HIGH VOLTAGE	RLF	RELIEF	VAR	VARIABLE
CRT	CATHODE RAY TUBE	IC	INTEGRATED CIRCUIT	RTNR	RETAINER	W/	WITH
DEG	DEGREE	ID	INSIDE DIAMETER	SCH	SOCKET HEAD	WSHR	WASHER
DWR	DRAWER	IDNT	IDENTIFICATION	SCOPE	OSCILLOSCOPE	XFMR	TRANSFORMER
		IMPLR	IMPELLER	SCR	SCREW	XSTR	TRANSISTOR

Replaceable Mechanical Parts—7A16P

CROSS INDEX—MFR. CODE NUMBER TO MANUFACTURER

Mfr. Code	Manufacturer	Address	City, State, Zip
000CY	NORTHWEST FASTENER SALES, INC.	7923 SW CIRRUS DRIVE	BEAVERTON, OR 97005
000FW	WESTERN SINTERING CO INC.	2620 STEVENS DRIVE	RICHLAND, WA 99352
00779	AMP, INC.	P O BOX 3608	HARRISBURG, PA 17105
08261	SPECTRA-STRIP CORP.	7100 LAMPSON AVE.	GARDEN GROVE, CA 92642
09922	BURNDY CORPORATION	RICHARDS AVENUE	NORWALK, CT 06852
22526	BERG ELECTRONICS, INC.	YOUK EXPRESSWAY	NEW CUMBERLAND, PA 17070
22599	ESNA, DIV. OF AMERACE CORPORATION	16150 STAGG STREET	VAN NUYS, CA 91409
24931	SPECIALITY CONNECTOR CO., INC.	2620 ENDRESS PLACE	GREENWOOD, IN 46142
57668	R-OHM CORP.	16931 MILLIKEN AVE.	IRVINE, CA 92713
71785	TRW, CINCH CONNECTORS	1501 MORSE AVENUE	ELK GROVE VILLAGE, IL 60007
73743	FISCHER SPECIAL MFG. CO.	446 MORGAN ST.	CINCINNATI, OH 45206
73803	TEXAS INSTRUMENTS, INC., METALLURGICAL MATERIALS DIV.	34 FOREST STREET	ATTLEBORO, MA 02703
77250	PHEOLL MANUFACTURING CO., DIVISION OF ALLIED PRODUCTS CORP.	5700 W. ROOSEVELT RD. P O BOX 500	CHICAGO, IL 60650 BEAVERTON, OR 97077
80009	TEKTRONIX, INC.	2530 CRESCENT DR.	BROADVIEW, IL 60153
83385	CENTRAL SCREW CO.	2527 GRANT AVENUE	SAN LEANDRO, CA 94579
85471	BOYD, A. B., CO.		
87308	N. L. INDUSTRIES, INC., SOUTHERN SCREW DIV.	P. O. BOX 1360	STATESVILLE, NC 28677
92101	SCHULZE MFG, 50 INGOLD RD BURLINGAME, CA 94010		

Fig. & Index No.	Tektronix Part No.	Serial/Model No.		Qty	Name & Description					Mfr Code	Mfr Part Number
		Eff	Dscont		1	2	3	4	5		
1-1	337-1064-04			2	SHIELD,ELEC:SIDE PLUG-IN UNITS					80009	337-1064-00
-2	366-1189-00			1	KNOB:GRAY					80009	366-1189-00
	213-0153-00			1	.SETScrew:5-40 X 0.125,STL BK OXD,HEX					000CY	OBD
-3	366-1184-00			1	KNOB:RED,0.127 ID X 0.392 OD X 0					80009	366-1184-00
	213-0153-00			1	.SETScrew:5-40 X 0.125,STL BK OXD,HEX					000CY	OBD
-4	358-0301-02			1	BUSHING,SLEEVE:GRAY PLASTIC					80009	358-0301-02
-5	366-1058-73			1	KNOB:LATCH,7A16P					80009	366-1058-73
					***** (ATTACHING PARTS) *****						
-6	214-1095-00			1	PIN,SPG,SPLIT:0.094 OD X 0.187 INCH LONG					22599	52-022-094-0187
					***** (END ATTACHING PARTS) *****						
-7	105-0076-02	B010100	B041689	1	REL BAR,LATCH:PLUG-IN UNIT					80009	105-0076-02
	105-0076-04	B041690		1	RELEASE BAR,LCH:PLUG-IN UNIT					80009	105-0076-04
-8	214-1280-00			1	SPRING,HLCPS:0.14 OD X 1.126" L,0.16" DIA					80009	214-1280-00
-9	333-1213-09			1	PANEL,FRONT:7A16P					80009	333-1213-00
-10	348-0235-00			2	SHLD GSKT,ELEC:4.734 INCH LONG					92101	OBD
-11	358-0408-00			1	BUSHING,SLEEVE:0.46 OD X 0.41 ID					80009	358-0408-00
-12	386-1447-87			1	SUBPANEL,FRONT:					80009	386-1447-87
					***** (ATTACHING PARTS) *****						
-13	213-0192-00			4	SCR,TPG,THD FOR:6-32 X 0.50 INCH,PNH STL					87308	OBD
-14	211-0101-00			2	SCREW,MACHINE:4-40 X 0.25,100 DEG,FLH STL					83385	OBD
-15	211-0016-00			5	SCREW,MACHINE:4-40 X 0.625 INCH,PNH STL					83385	OBD
					***** (END ATTACHING PARTS) *****						
-16	----			1	CKT BOARD ASSY:SWITCH(SEE A50 REPL)						
-17	----			16	.SWITCH,PB ASSY:(SEE S50100,S50108, S50110						
	----			-	.S50120,S50200,S50202,S50206,S50208,S5021						
	----			-	.S50214,S50220,S50400,S50410,S50500,S5050						
	----			-	.S50510 REPL)						
-18	136-0263-04			8	.SOCKET,PIN TERM:FOR 0.025 INCH SQUARE PIN					22526	75377-001
-19	----			1	CKT BOARD ASSY:L.E.D.(SEE A40 REPL)						
-20	131-0589-00			8	.TERMINAL,PIN:0.46 L X 0.025 SQ					22526	48283-029
-21	131-1362-01			1	.CONN,RCPT,ELEC:CKT CD,DBL ROW,15 CONTACTS					80009	131-1362-01
-22	361-0865-00			5	.SPACER,SLEEVE:0.28 L X 0.14 ID,BRS,CU,SN					80009	361-0865-00
	672-0645-00			1	CKT BOARD ASSY:PROGRAMMABLE ATTENUATOR					80009	672-0645-00
					***** (ATTACHING PARTS) *****						
-23	211-0016-00			1	SCREW,MACHINE:4-40 X 0.625 INCH,PNH STL					83385	OBD
					***** (END ATTACHING PARTS) *****						
	----			-	CKT BOARD ASSY INCLUDES:						
-24	200-1925-00			1	.COVER,CHASSIS:LOGCELL ATTENUATOR					80009	200-1925-00
					***** (ATTACHING PARTS) *****						
-25	211-0101-00			3	.SCREW,MACHINE:4-40 X 0.25,100 DEG,FLH STL					83385	OBD
					***** (END ATTACHING PARTS) *****						
-26	----			1	.CKT BOARD ASSY:ATTENUATOR(SEE A10 REPL)						
					***** (ATTACHING PARTS) *****						
-27	211-0007-00			3	.SCREW,MACHINE:4-40 X 0.188 INCH,PNH STL					83385	OBD
					***** (END ATTACHING PARTS) *****						
	----			-	CKT BOARD ASSY INCLUDES:						
-28	361-0791-00			1	.SPACER,SLEEVE:0.225 L X 0.187 ID,BRASS					80009	361-0791-00
-29	129-0597-00			3	.SPACER,POST:0.415 L,4-40 THD,BRS,0.219					80009	129-0597-00
-30	136-0252-04			24	.SOCKET,PIN TERM:U/W 0.016-0.018 DIA PINS					22526	75060-007
-31	131-0590-00			14	.CONTACT,ELEC:0.71 INCH LONG					22526	47351
-32	131-1852-00			7	.CONTACT,ELEC:GROUND					80009	131-1852-00
-33	136-0514-00	B010100	B041414	1	.SKT,PL-IN ELEC:MICROCIRCUIT,8 DIP					73803	CS9002-8
	136-0727-00	B041415		1	.SKT,PL-IN ELEC:MICROCKT,8 CONTACT					09922	DILB8P-108
-34	----			1	.CKT BOARD ASSY:ACTUATOR(SEE A20 REPL)						
					***** (ATTACHING PARTS) *****						
-35	211-0007-00			3	.SCREW,MACHINE:4-40 X 0.188 INCH,PNH STL					83385	OBD
					***** (END ATTACHING PARTS) *****						
	----			-	CKT BOARD ASSY INCLUDES:						
-36	129-0593-00			3	.SPACER,POST:0.377 L,W/4-40THD,BRS,0.219					80009	129-0593-00
-37	136-0263-04			14	.SOCKET,PIN TERM:FOR 0.025 INCH SQUARE PI					22526	75377-001
-38	131-1852-00			8	.CONTACT,ELEC:GROUND					80009	131-1852-00
-39	129-0647-00			3	.SPACER,POST:0.205 L,W/4-40 THRU THD,BRS					80009	129-0647-00
	198-3681-00			1	.WIRE SET,ELEC:					80009	198-3681-00

Replaceable Mechanical Parts—7A16P

Fig. & Index No.	Tektronix Part No.	Serial/Model No. Eff Dscnt	Qty	1 2 3 4 5	Name & Description	Mfr Code	Mfr Part Number
1-40	175-0826-00		FT		...WIRE,ELECTRICAL:3 WIRE RIBBON	80009	175-0826-00
-42	175-0830-00		FT		...WIRE,ELECTRICAL:7 WIRE RIBBON	08261	SS-0726-710610C
-43	131-0707-00		15		...CONNECTOR,TERM:22-26 AWG,BRS & CU BE GO	22526	47439
-44	352-0161-00		1		...HLDR,TERM CONN:3 WIRE,BLACK	80009	352-0161-00
-45	352-0163-02		1		...CONN BODY,PL,EL:5 WIRE RED	80009	352-0163-02
-46	352-0165-00		1		...CONN BODY,PL,EL:7 WIRE BLACK	80009	352-0165-00
-47	131-0679-02		2		.CONNECTOR,RCPT,;BNC,MALE,3 CONTACT ***** (ATTACHING PARTS) *****	24931	28JR270-1
-48	220-0695-00		2		.NUT,PLAIN,LOCK:0.500-28 X 0.90 INCH,BRS	73743	OBD
-49	210-1039-00		2		.WASHER,LOCK:INT,0.521 ID X 0.625 INCH O ***** (END ATTACHING PARTS) *****	24931	OBD
-50	361-0790-00		1		.SPACER,PLATE:0.09 X 1.5 X 0.312,BRASS	80009	361-0790-00
-51	252-0571-00		1		.NEOPRENE EXTR:CHAN,0.234 X 0.156	85471	DIE#1353
-52	441-1315-00		1		.CHASSIS,AITEN:LOGCELL VERSION	80009	441-1315-00
-53	-----		1		CKT BOARD ASSY:AMPLIFIER(SEE A60 REPL) ***** (ATTACHING PARTS) *****		
-54	211-0155-00		4		SCREW,EXT,RLV B:4-40 X 0.375 INCH,SST ***** (END ATTACHING PARTS) *****	80009	211-0155-00
	-----		-		CKT BOARD ASSY INCLUDES:		
-55	129-0317-00		1		.POST,ELEC-MECH:4-40 X 0.187 X 0.125 INCH	80009	129-0317-00
-56	361-0238-00		4		.SPACER,SLEEVE:0.25 OD X 0.34 INCH LONG	80009	361-0238-00
-57	131-0608-00		15		.TERMINAL,PIN:0.365 L X 0.025 PH BRZ GOLD	22526	47357
-58	136-0263-04		26		.SOCKET,PIN TERM:FOR 0.025 INCH SQUARE PIN	22526	75377-001
-59	136-0252-04		32		.SOCKET,PIN TERM:U/W 0.016-0.018 DIA PINS	22526	75060-007
-60	214-0579-00		1		.TERM,TEST POINT:BRS CD PL	80009	214-0579-00
-61	131-1003-00		4		.CONN,RCPT,ELEC:CKT BD MT,3 PRONG	80009	131-1003-00
-62	131-0566-00		1		.BUS CONDUCTOR:DUMMY RES,2.375,22 AWG	57668	JWW-0200E0
-63	214-1140-00		4		SPRING,HLCPS:0.251 OD X 0.375"L,SST WIRE	80009	214-1140-00
-64	386-1657-00		6		SUPPORT,CKT BD:	80009	386-1657-00
-65	-----		1		CKT BOARD ASSY:SHIELD(SEE A70 REPL)		
-66	384-1464-00		1		EXTENSION SHAFT:2.025 L X 0.125 OD,SST	80009	384-1464-00
-67	-----		1		CKT BOARD ASSY:PROGRAM LOGIC(SEE A30 REPL) ***** (ATTACHING PARTS) *****		
-68	211-0198-00		2		SCREW,MACHINE:4-40 X 0.438 PNH,STL,POZ ***** (END ATTACHING PARTS) *****	77250	OBD
	-----		-		CKT BOARD ASSY INCLUDES:		
-69	214-1190-00		1		.CPLG,SHAFT,RGD:0.125 OD TO 0.125 OD,AL	80009	214-1190-00
-70	351-0180-00		1		.SLIDE,GUIDE:SWITCH ACTUATOR	80009	351-0180-00
-71	214-1136-00		1		.ACTUATOR,SL SW:DUAL DPST	80009	214-1136-00
-72	131-0604-00		3		.CONTACT,ELEC:CKT BD SW,SPR,CU BE	80009	131-0604-00
-73	-----		1		.RESISTOR,VAR:(SEE R200 REPL)		
-74	361-0515-00		1		.SPACER,SWITCH:PLASTIC	80009	361-0515-00
-75	129-0317-00		2		.POST,ELEC-MECH:4-40 X 0.187 X 0.125 INCH	80009	129-0317-00
-76	131-0993-00		4		.BUS,CONDUCTOR:2 WIRE BLACK	00779	850100-01
-77	136-0578-00	B010100	B039999	3	.SKT,PL-IN ELEK:MICROCKT,24 PIN,LOW PROFIL	73803	C S9002-24
	136-0578-00	B040000		4	.SKT,PL-IN ELEK:MICROCKT,24 PIN,LOW PROFIL	73803	C S9002-24
-78	136-0252-04		4		.SOCKET,PIN TERM:U/W 0.016-0.018 DIA PINS	22526	75060-007
-79	214-0579-00	B010100	B041606	14	.TERM,TEST POINT:BRS CD PL	80009	214-0579-00
	214-0579-00	B041607		12	.TERM,TEST POINT:BRS CD PL	80009	214-0579-00
-80	136-0623-00	B010100	B040951	4	.SOCKET,PLUG-IN:40 DIP,LOW PROFILE	73803	CS9002-40
	136-0623-00	B040592		1	.SOCKET,PLUG-IN:40 DIP,LOW PROFILE	73803	CS9002-40
-81	136-0260-02		1		.SKT,PL-IN ELEK:MICROCIRCUIT,16 DIP,LOW CL	71785	133-51-92-008
-82	136-0634-00		1		.SOCKET,PLUG-IN:20 LEAD DIP,CKT BD MTG	73803	CS9002-20
-83	131-0590-00		26		.CONTACT,ELEC:0.71 INCH LONG	22526	47351
	131-0608-00		13		.TERMINAL,PIN:0.365 L X 0.025 PH BRZ GOLD	22526	47357
-84	351-0188-00		4		.GUIDE-POST,LOCK:0.65 INCH LONG	80009	351-0188-00
-85	131-1003-00		4		.CONN,RCPT,ELEC:CKT BD MT,3 PRONG	80009	131-1003-00
-86	386-1402-00		1		PANEL,REAR: ***** (ATTACHING PARTS) *****	80009	386-1402-00
-87	213-0192-00		4		SCR,TPG,THD FOR:6-32 X 0.50 INCH,PNH STL ***** (END ATTACHING PARTS) *****	87308	OBD
-88	220-0547-05		2		NUT BLOCK:4-40 X 0.25W X0.38 L ***** (ATTACHING PARTS) *****	000FW	OBD
-89	211-0105-00		2		SCREW,MACHINE:4-40 X 0.188,100 DEG,FLH ST ***** (END ATTACHING PARTS) *****	83385	OBD

Fig. & index No.	Tektronix Part No.	Serial/Model No.		Qty						Name & Description	Mfr Code	Mfr Part Number
		Eff	Dscont		1	2	3	4	5			
1-90	214-1061-00			1						SPRING,GROUND:FLAT	80009	214-1061-00
-91	426-0505-07			1						FR SECT,PLUG-IN:TOP	80009	426-0505-07
-92	214-1054-00			1						SPRING,FLAT:0.825 X 0.322,SST	80009	214-1054-00
-93	105-0075-00			1						BOLT,LATCH:7A & 7B SER PL-IN	80009	105-0075-00
-94	426-0603-06			1						FR SECT,PLUG-IN:BOTTOM	80009	426-0603-06
	198-3682-00			1						WIRE SET,ELEC:	80009	198-3682-00
	334-3438-00			1						MARKER,IDENT:MARKED TURN OFF POWER	80009	334-3458-00

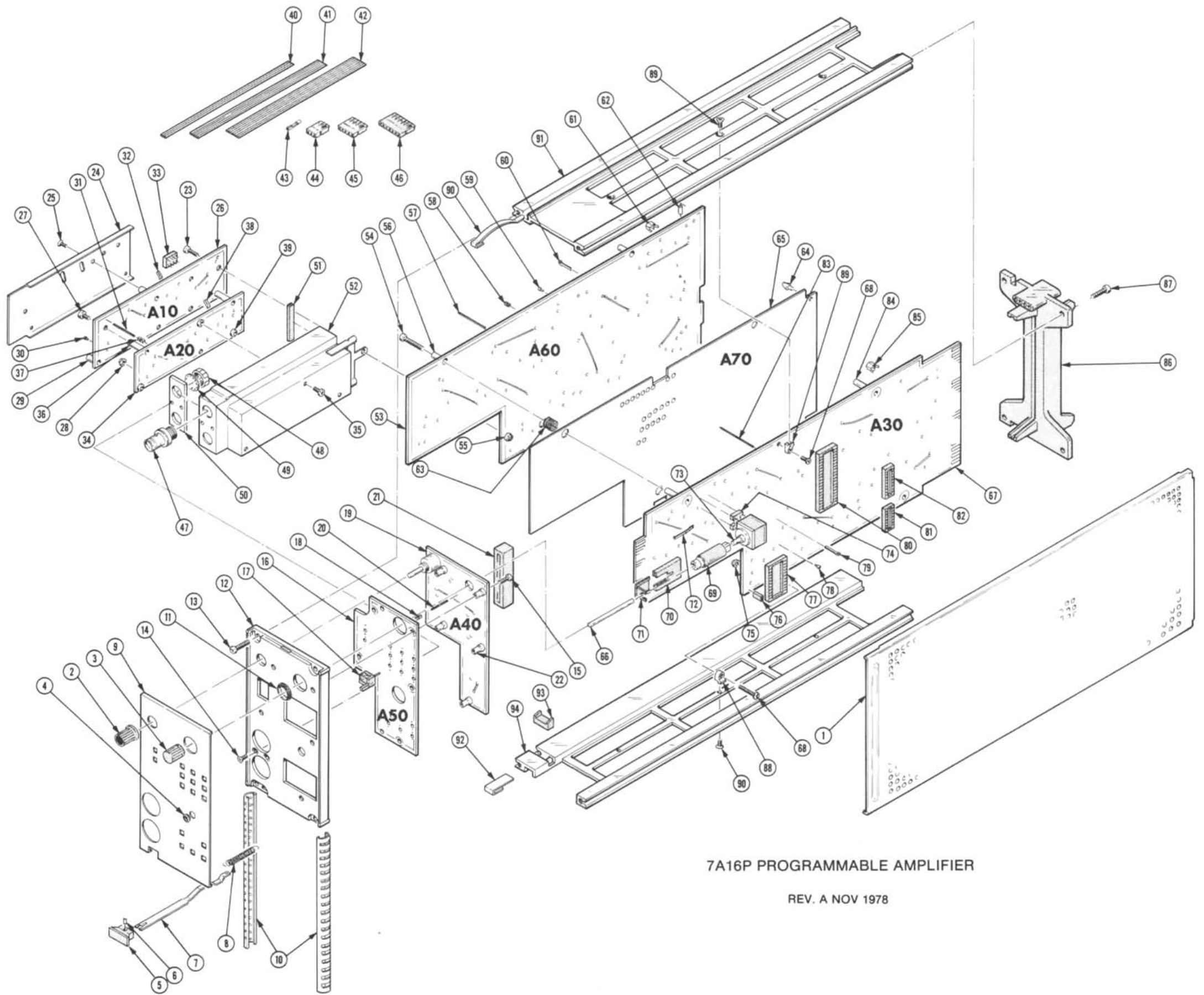

7A16P PROGRAMMABLE AMPLIFIER

REV. A NOV 1978

Fig. & Index No.	Tektronix Part No.	Serial/Model No.		Qty						Name & Description	Mfr Code	Mfr Part Number
		Eff	Dscont		1	2	3	4	5			
	070-2308-00			1						MANUAL, TECH: INSTRUCTION	80009	070-2308-00

7A16P HIGH-LEVEL (ASCII) COMMANDS

Header	Argument	Description
INP	A B	Select A input connector. Select B input connector.
RIN	HI LOW	Set input impedance high (1 MΩ). Set input impedance low (50 Ω).
CPL	AC DC GND	Select AC input coupling. Select DC input coupling. Ground (disconnect) the input.
BW	LIM FUL	Select limited bandwidth (20 MHz). Select full bandwidth (200 MHz).
POL	NOR INV	Select normal polarity. Select inverted polarity.
V/D	xxxx	Set VOLTS/DIV (0.01 to 5 div). ¹
POS	xxxx	Set trace position (-10.22 to +10.24 div). ²
VAR	OFF ON	Turn off VARIABLE (Volts/div). Turn on VARIABLE (Volts/div).
PRB	X1 X10 X100	Probe attenuation is 1X Probe attenuation is 10X Probe attenuation is 100X } query only
ID		Returns plug-in type.
SET		Queries all functions (except the query only ones).

¹ Accepts <NR1>, <NR2>, or <NR3>; query returns <NR3>. With a 10X probe, range is 0.1 to 50; with a 100X probe, range is 1 to 500. (V/D 0 means that probe is on IDENTIFY.)

² Accepts <NR1>, <NR2>, or <NR3>; query returns <NR2>.

7A16P LOW-LEVEL (HEXADECIMAL) CODES

Address	Data	Description
00	16	Plug-in Type (query only) Any data other than hex 16 written to this address causes a command error.
01	00 40	Input Connector Input A Input B
02	80 00	Input Impedance Low (50 ohms) High (1 Megohm)
03	00 10 20	Input Coupling AC DC Ground
04	05 04 06 01 00 02 09 08 0A	Volts/Division (ignores probe attenuation) 10 millivolts/division 20 millivolts/division 50 millivolts/division 100 millivolts/division 200 millivolts/division 500 millivolts/division 1 volts/division 2 volts/division 5 volts/division
05 06	xx xx	Trace Position (high two bits) Trace Position (low eight bits) Position range is +10.24 divisions (0000) to -10.24 divisions (03FF). Center screen=0200. Step size = 0.02 div.
07	00 08	Polarity Inverted Normal

LOW-LEVEL CODES (cont)

Address	Data	Description
08	00 40	Bandwidth Limit 20 Megahertz limit Full bandwidth
09	00 20	Calibrated/Variable Gain Deflection factors can be manually varied by VARIABLE control. Returns deflection factors to calibrated value.
0A	00 04 14 1C	Probe Attenuation (query only). A write to this address is ignored. Probe IDENTIFY switch is pressed 100X probe 10X probe 1X or unencoded probe

HIGH-LEVEL MESSAGE FORMATS

SET: <header> <argument>

QUERY: <header>? ; responds with <argument>

LOW-LEVEL MESSAGE FORMATS

SET: 15* QUERY: 11*
 <address> <address> <address>
 <data> <count>
 <data> <checksum>
 <checksum>

*hexadecimal

The <address> and <data> bytes are taken from Table A. The <checksum> is the 2's complement of the modulo-256 sum of the preceding message bytes.

MANUAL CHANGE INFORMATION

At Tektronix, we continually strive to keep up with latest electronic developments by adding circuit and component improvements to our instruments as soon as they are developed and tested.

Sometimes, due to printing and shipping requirements, we can't get these changes immediately into printed manuals. Hence, your manual may contain new change information on following pages.

A single change may affect several sections. Since the change information sheets are carried in the manual until all changes are permanently entered, some duplication may occur. If no such change pages appear following this page, your manual is correct as printed.

DESCRIPTION

EFF SN B042360

REPLACEABLE ELECTRICAL PARTS & SCHEMATIC CHANGES

CHANGE TO:

A60 670-4915-03 CKT BOARD ASSY:AMPLIFIER

REMOVE:

A60C538	281-0814-00	CAP,FXD,CER DI:100 PF,10%,100V
A60R528	315-0201-00	RES,FXD,CMPSN:200 OHM,5%,0.25W
A60RT526	307-0127-00	RES,THERMAL:1K OHM,10%

These parts are shown on Diagram 2.

PARTIAL DIAGRAM 2
(after M50089)

