



For more Hi-Fi manuals and set-up information
please visit www.hifiengine.com

The Citation Twelve

Stereophonic Power Amplifier

INTRODUCTION

“... for the sake of music and our demanding love of it.”

The name Citation has always meant something special to music lovers. When Citation was first introduced a decade ago, it represented a major breakthrough in high fidelity design. “Citation Sound” became the industry’s new standard of excellence and captured the imagination of audiophiles throughout the world. Hans Fantel, noted audio authority, stated in a glowing report that “the Citation group bore eloquent witness to the one vital aspect of audio that for so many of us has elevated high fidelity from a casual hobby to a lifelong interest; the earnest attempt to reach an ideal — not for the sake of technical showmanship — but for the sake of music and our demanding love of it.”

- Two individual power supplies deliver superb regulation for absolute stability and extended low frequency response. Handling of transients is effortless at any power level.
- Hermetically sealed heavy duty silicon output devices deliver exceptionally wide frequency response at full power output with low distortion.
- Fail-safe operation with all types of speakers including electrostatics. Amplifier can handle high power transients, short circuits or unloaded condition without damage to the output stage.
- Square wave response throughout the entire audio spectrum. Phase shift at 20 Hertz is less than five degrees. Amplifier extends to below one hertz with less than fifteen degrees phase shift. Rise time faster than two microseconds at 20K Hertz.
- Computer grade components guarantee long, trouble-free life.
- Heavy duty heat sinks keep amplifier cool even under stress operating conditions.
- Two thermal cutouts, one per channel, remove power from the output stage when heat build-up exceeds 80 degrees C. Two series-type limiting relays protect amplifier from short circuits. Reset automatically once short is removed.
- Two year service warranty on parts and labor.

CITATION® TWELVE SPECIFICATIONS

POWER OUTPUT:	60 WATTS MIN. RMS PER CHANNEL, BOTH CHANNELS DRIVEN INTO 8 OHMS FROM 20Hz TO 20kHz, WITH LESS THAN 0.2% THD
Power Bandwidth:	From 5Hz to 30kHz at less than 0.2% THD into 8 ohms, both channels driven simultaneously at 30 watts per channel.
Frequency Response:	From 5Hz to 70kHz at less than 0.2% THD into 8 ohms, both channels driven simultaneously at 1 watt per channel.
Square Wave Rise Time:	Better than 2 microseconds
Total Harmonic Distortion:	Less than 0.2% from 250 milliwatts to 45 watts RMS, both channels driven simultaneously into 8 ohms from 5Hz to 30kHz.
Intermodulation Distortion:	Less than 0.15% at rated power output.
Hum and Noise:	Better than 100dB below 60 watts
Damping Factor:	40:1
Input Impedance:	30k ohms
Input Sensitivity:	1.5 volts for 60 watts
Phase Shift:	Less than 5 degrees at 20Hz
Inputs:	One RCA type input terminal per channel
Outputs:	Instrument type binding posts. Accepts speakers from 4 to 16 ohms.
Dimensions:	5 $\frac{7}{16}$ " H x 12 $\frac{3}{16}$ " W x 12 $\frac{5}{8}$ " D (complete with metal cage) [14.0 cm. H x 31.1 cm. W x 31.7 cm. D]
Weight:	30 pounds

UNPACKING

After unpacking the Citation Twelve, inspect it carefully for signs of transit damage. The amplifier was subjected to numerous quality control tests and inspections prior to packing and should therefore be in perfect operating condition. If damage is visible, notify your dealer at once. If the amplifier was shipped to you, notify the transportation company without delay. HARMAN-KARDON will cooperate with you in such instances, but only YOU can recover from the carrier for damage incurred during shipment.

POWER REQUIREMENTS

Connect the line cord into any outlet furnishing 117 volts, 50-60 Hertz A.C. current. The voltage may vary between 110-125 volts without affecting the performance of the amplifier. It would be advantageous to connect the Citation Twelve directly to the switched A.C. receptacle on the rear of your Citation Eleven preamplifier (or any preamplifier which offers a switched A.C. outlet) to permit you to turn the amplifier on and off with the preamplifier's on/off switch.

A neon indicator light located on the front escutcheon will glow when the amplifier is receiving A.C. power from the line.

For use in areas which require 50 Hertz, 220 volt current, the amplifier must be modified in the following manner. It is advisable to have this modification made by a competent service technician.

1. 220 volt, 50 Hertz conversion involves the re-wiring of two wires per channel.
2. Remove bottom plate of amplifier.
3. Locate black and brown wires attached to fuse post. Unsolder brown wire only. On left channel remove 1650 ohm 10 watt resistor. Black wire remains on fuse post.
4. Locate black/white wire on the lug strip directly behind the fuse post and unsolder from lug strip.
5. Join the black/white wire you have just removed with the brown wire removed in step 3 and solder together to the vacant lug on the lug strip. On left channel, solder the 1650 ohm 10 watt resistor to this lug.
6. Repeat exact procedure for other channel.

7. Replace 3A-3AG fuse supplied with Citation Twelve for 117 volt, 50-60 Hertz operation with 1.5A-3AG fuse for 220 volt, 50-60 Hertz operation.

8. Replace bottom plate.

VENTILATION

Although your new Citation Amplifier rarely develops high heat, it is still recommended that you leave the back of the cabinet open. If this is not possible, provide several large holes or slots as low down and as high up in the cabinet back as possible. As an alternate, holes may be provided in the sides, bottom or top of the cabinet. Remember that really effective ventilation requires provision for cool air to enter at the bottom and hot air to leave at the top. A minimum clearance of two (2) inches should be allowed on each side and in the rear, between the chassis and the cabinet, and six (6) inches is required above it.

Isolate any accessories which might interfere with ventilation. For example, do not drape plastic or rubber covered interconnecting cable over the finned heat dissipating devices on the front panel.

WIRE DRESSING

Speaker wiring and input cables connected to the front panel of the Citation Twelve should be routed underneath the unit in order to prevent interference with the cooling fins of the power transistor heat sinks.

CONNECTING THE SPEAKERS FOR STEREO OPERATION

Your two speakers should be identical to obtain optimum results. Experts agree that a perfectly matched system offers the best stereophonic reproduction. The speakers should be placed along the same wall approximately 8 to 10 feet apart depending upon room size and furniture placement. It may be necessary to experiment with speaker placement until best results are obtained.

Use any type of stranded wire to connect your speakers to the Citation Amplifier. Lamp cord (zip cord) #18 gauge is excellent and may be dressed easily around the molding for an inconspicuous and neat installation. Do not drive staples or tacks through the center of the wire for this may short out the two sections which will decrease volume or short out the speakers entirely. It is permissible to use approximately 50 feet of speaker connecting wire for each speaker without loss of volume.

1. Connect one length of lamp cord to your left speaker system. If the cord has color-coded insulation, connect red to plus (+) and black to minus (-), or ground.

2. Connect the other end of the lamp cord to the **LEFT SPEAKER** terminals located on the front apron of the amplifier. The speaker output terminals are of a special industrial grade found in laboratories on professional test equipment. They can accept any type of wire termination such as bare tinned wire, spade lug, banana plug, etc. If the wire is color-coded, connect red to plus (+) and black to minus (-), or ground.

3. Now connect another length of lamp cord to your right speaker. Observe polarity.

4. Connect the other end of the lamp cord to the **RIGHT SPEAKER** terminals. Observe polarity.

Dress the bare wires carefully so they do not touch the chassis or each other to cause a short circuit. Observe the same precaution when connecting the lamp cord to the speaker. If a short circuit does occur, the amplifier will turn itself off automatically, and will continue to cycle until the short is removed.

DIAGRAM A
CONNECTING STEREO SPEAKERS

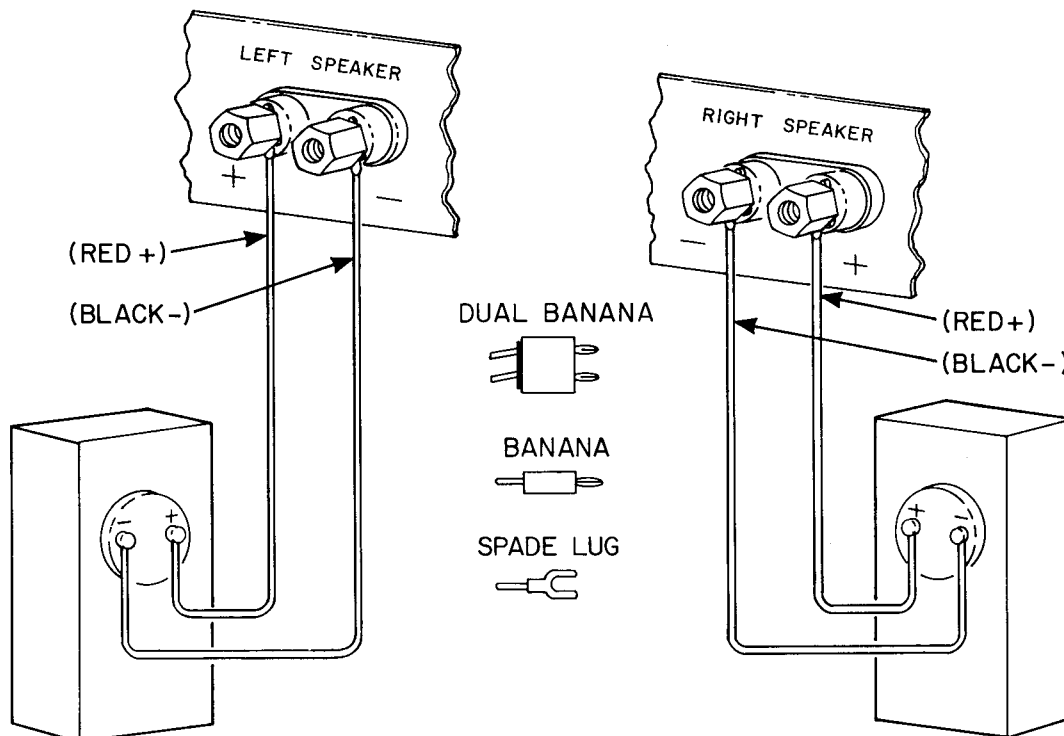

SPEAKER PHASING

Checking for proper phase and correcting, if required, is quite simple.

1. Place your stereo preamplifier in the A + B or monophonic mode of operation.
2. Play a record, tape, or FM broadcast which has a single speaking or singing voice, or a solo instrument.
3. The voice or instrument should appear to be coming from an area directly between the two speakers. If the speakers are out of phase, the sound will appear to be coming from the two individual speakers.
4. If you determine that the speakers are out of phase, simply disconnect the leads from only one of the speakers and reverse them. The system will then be in phase.

This completes your speaker connections. Since the Citation Twelve does not contain audio output transformers, it is not necessary to match the impedance of your speakers to the amplifier. The amplifier will perform perfectly with any speaker which has an impedance of 4, 8 or 16 ohms.

CONNECTING SPEAKERS FOR MONOPHONIC OPERATION

If the Citation Twelve is to be used monophonically and stereo is to be added at a later date, **both** speaker output terminals must be terminated into a proper load. Refer to Diagram B for complete details. **DO NOT TIE BOTH CHANNELS TOGETHER IN PARALLEL.**

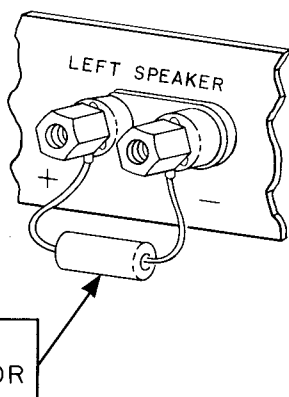

8 OHM 20 WATT
WIRE WOUND RESISTOR

(RESISTOR CAN ALSO BE
16 OHM 20 WATT OR
4 OHM 20 WATT
WIRE WOUND)

TECHNICAL INFORMATION

BIAS ADJUSTMENT: This adjustment has been made at the factory and it should not be necessary to touch the bias potentiometer for the life of the amplifier. The only time that readjusting bias will be required is when output transistors are changed. This adjustment should be made only by a competent service technician.

FUSES: There are two fuses protecting the Citation Twelve. Both are 3A-3AG types. If replacement is required use only this size. A larger fuse will not protect the amplifier and damage may result.

CONNECTING THE PREAMPLIFIER

Use standard shielded patch cords with RCA plugs to connect your preamplifier to the Citation Twelve.

Connect one patch cord from the Left Channel Output of your preamplifier to the Left Channel Input on the front apron of the Citation Twelve and an additional patch cord from the Right Channel Output of your preamplifier to the Right Channel Input of the Citation Twelve.

WARNING: DO NOT REMOVE OR MANIPULATE THE PLUGS OF THESE PATCH CORDS WHILE THE CITATION IS ON. THE TRANSIENT WHICH MAY BE CAUSED BY AN OPEN GROUND OR OPEN SIGNAL LEAD COULD DAMAGE YOUR SPEAKERS. ALWAYS TURN THE SYSTEM OFF BEFORE UNPLUGGING CONNECTIONS.

DIAGRAM B
CONNECTING MONOPHONIC SPEAKER

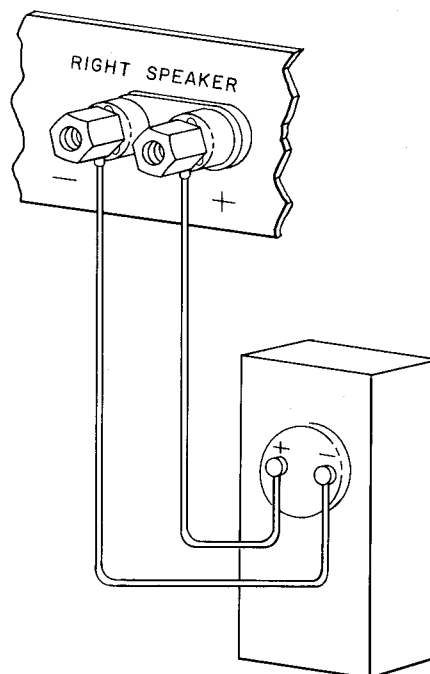

IMPORTANT NOTICE TO USER

In certain circumstances it may be required to protect your speakers from overload and possible damage as the Citation Twelve produces in excess of 60 watts, RMS, per channel, both channels driven simultaneously. Although there are many high quality speakers which can handle this power, it is still recommended, as a safety factor, that your speakers be fused for their protection.

The chart below indicates the appropriate size fuse to use with speakers that are conservatively rated with music power specifications. It has been our experience that very few speakers are rated in terms of sine wave (RMS) power. However, in the event your speaker is rated according to this rigid specification, contact the speaker manufacturer for the comparable music power rating.

Speaker Rating Average Program Material	Fast Acting Fuse For 8 Ohm Speaker	Fast Acting Fuse For 4 Ohm Speaker
40 Watts	1.0 AMP	1.5 AMP
50 Watts	1.0 AMP	1.5 AMP
60 Watts	1.0 AMP	1.5 AMP
80 Watts	1.5 AMP	2.0 AMP
100 Watts	1.5 AMP	2.0 AMP
150 Watts	1.5 AMP	2.0 AMP
200 Watts	1.5 AMP	2.0 AMP

The speaker fuse should be in the positive speaker line and located at or near the speaker input terminals. It should NOT be located at the amplifier speaker terminals.

The fuse and fuse holder can be obtained at any electronic supply store. You may use either an in-line or block type fuse, as shown in the drawing below.

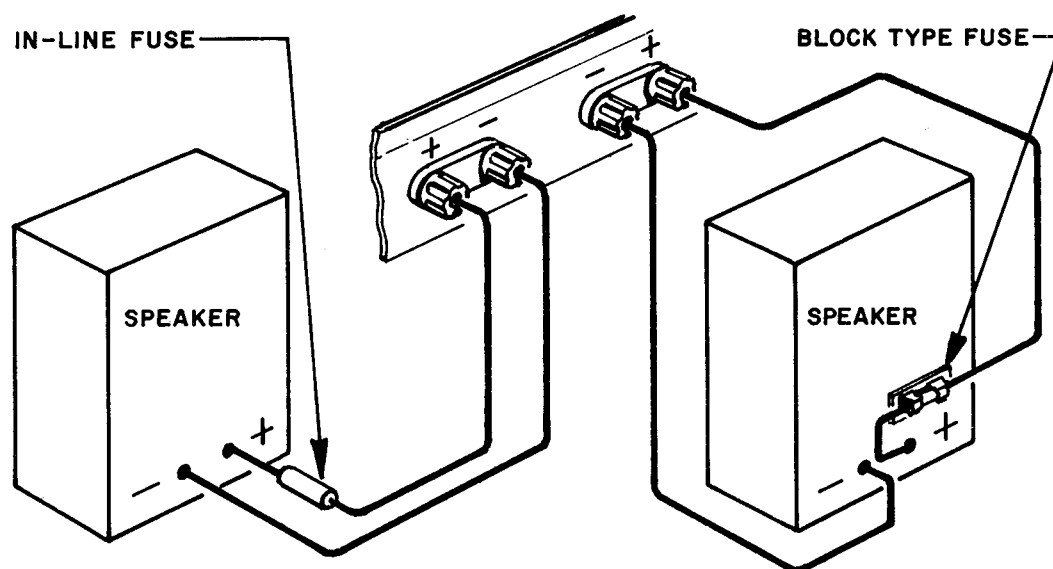

**CITATION TWELVE
FRONT PANEL**

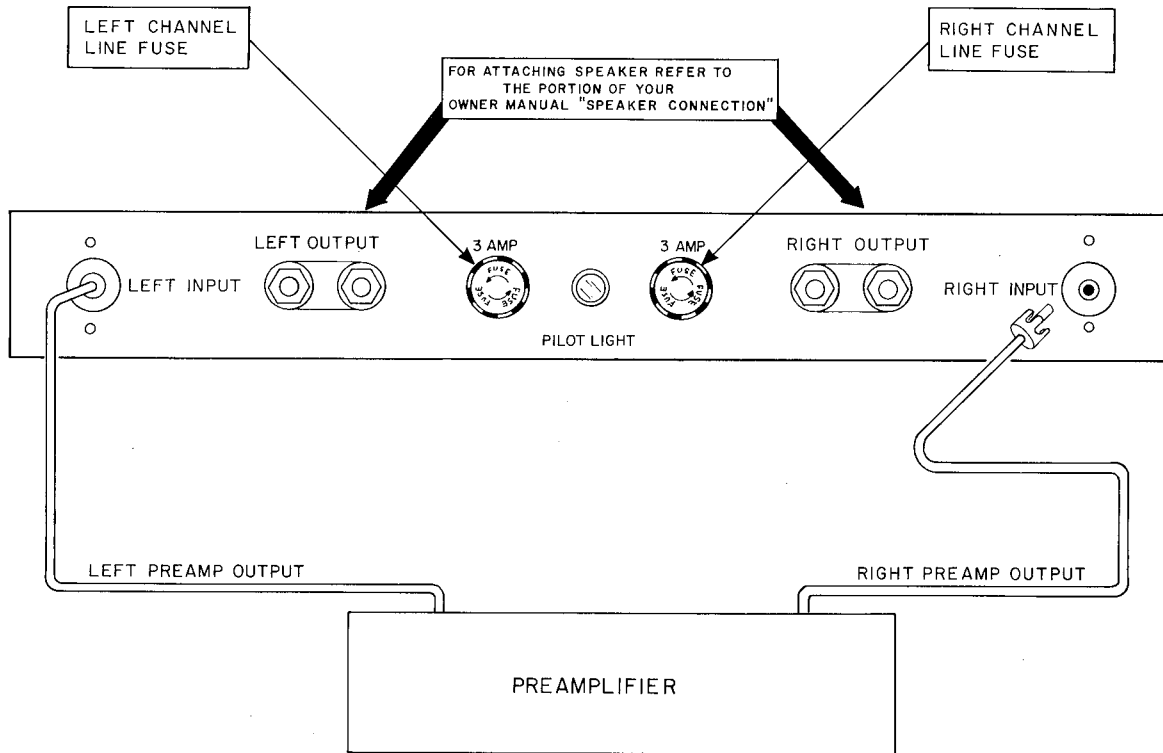

**CITATION TWELVE DELUXE
FRONT PANEL**

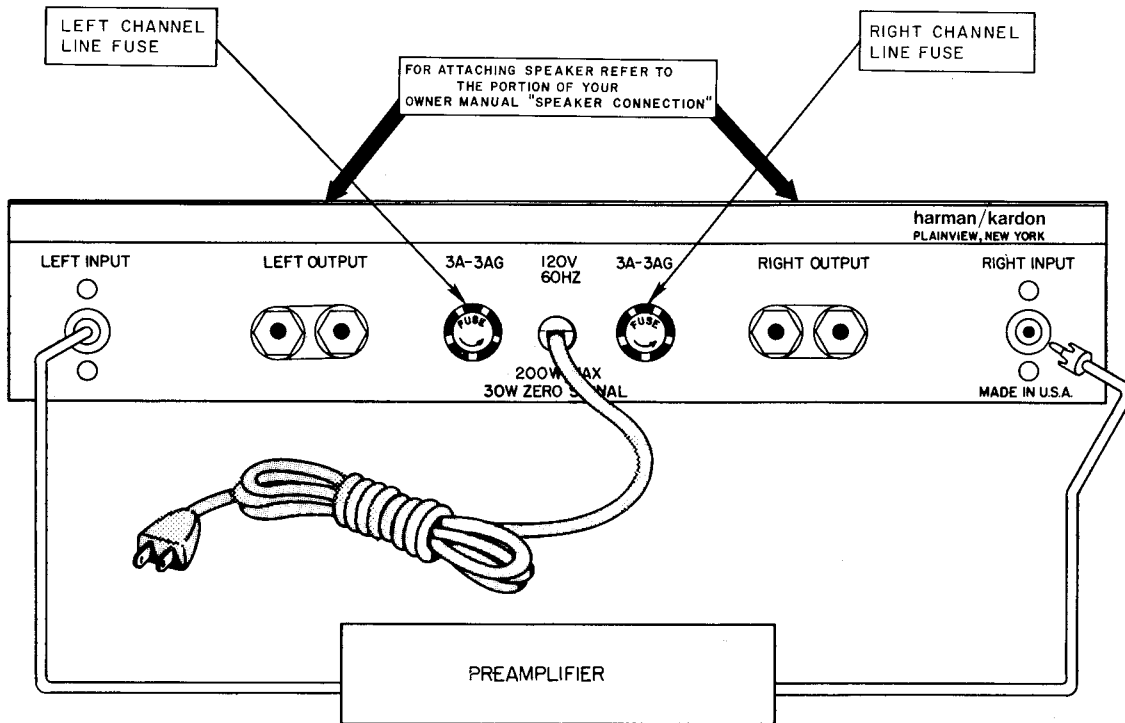

LIMITED 2 YEAR WARRANTY AND SERVICE POLICY

We warrant this product to be free from defects in material and workmanship under normal use and service, and in accordance with the conditions set forth below. Should a defect occur within the period specified, provided that the unit is returned to either Harman/Kardon Plainview or an authorized Harman/Kardon warranty station, transportation prepaid, and which our examination shall disclose to our satisfaction to be defective, we will, for a period of **two (2) years** from the date of purchase, either repair or replace and install any defective parts of this product free of charge.

This warranty is not applicable to any product which shall have been repaired or altered in any way so as to, in our judgment, affect its stability or reliability; or to any product that has been subject to neglect, misuse, abuse, or accident; or which has had its serial number altered, effaced or removed. Neither shall this warranty apply to any product which has been connected other than in accordance with instructions furnished by us.

Exceptions:

This warranty does not include any obligation as to the repair or replacement of any wooden enclosure or other similar accessory due to damage incurred after initial delivery, nor to any responsibility for transportation charges incurred in the shipment of the defective product to or from Harman/Kardon Plainview or any of its authorized warranty stations.

The duration of implied warranties is 2 years. Our obligation under any warranty, express or implied, is limited to repair or replacement of any unit found to be defective. Under no circumstances shall we be liable for incidental or consequential damages.

To obtain service under the terms of the warranty policy, it is necessary for you to retain your **ORIGINAL BILL OF SALE**. Any card or other registration device does not constitute proof of purchase nor will it be regarded as such. In the event your equipment requires service during the two-year warranty period, only presentation of your **ORIGINAL BILL OF SALE** to either an authorized warranty station or the factory itself will insure your rights under the warranty policy described above.

We have a Customer Relations Department equipped to handle any questions you may have regarding the installation or operation of your unit. Feel free to correspond with us at any time. We will make every effort to give you prompt and complete advice on any inquiry.

If any problem cannot be resolved through correspondence with the factory, we may wish to refer you to an authorized warranty station in your area if we feel this is best in your situation. Similarly, we may prefer to authorize the return of your unit to the factory in Plainview, New York. Should this possibility arise, a Service Return Authorization form, and packing and shipping instructions will be mailed to you. This material will identify your unit as belonging to you during its processing through our Service Department and allow us to return it to you in the shortest possible time. This authorization form **must accompany** your unit when it is returned to us.

UNDER NO CIRCUMSTANCES SHOULD YOU SHIP A UNIT TO US WITHOUT PRIOR AUTHORIZATION. You risk major delays in the processing of your unit and the possibility of loss of your equipment.